

AC axial fan

sickle-shaped blades (S series), single-intake

Fan housing with guard grille

ebm-papst Mulfingen GmbH & Co. KG

Bachmühle 2 · D-74673 Mulfingen

Phone +49 7938 81-0

Fax +49 7938 81-110

sales@fansco.com

www.fansco.com

Limited partnership · Headquarters Mulfingen

Amtsgericht (court of registration) Stuttgart · HRA 590344

General partner Elektrobau Mulfingen GmbH · Headquarters Mulfingen

Amtsgericht (court of registration) Stuttgart · HRB 590142

Nominal data

Type	W4E420-CP03-70		
Motor	M4E074-GA		
Phase		1~	1~
Nominal voltage	VAC	115	115
Frequency	Hz	60	60
Method of obtaining data		fa	fa
Valid for approval/standard		CE	UL 1004-3
Speed (rpm)	min ⁻¹	1620	1620
Power consumption	W	280	295
Current draw	A	2.45	2.5
Capacitor	µF	25	25
Capacitor voltage	VDB	220	220
Capacitor standard		S2 (CE)	S2 (CE)
Max. back pressure	Pa	80	80
Max. back pressure	in. wg	0.32	0.32
Min. ambient temperature	°C	-25	-25
Max. ambient temperature	°C	40	40

ml = Max. load · me = Max. efficiency · fa = Free air · cs = Customer specification · ce = Customer equipment
Subject to change



AC axial fan

sickle-shaped blades (S series), single-intake

Fan housing with guard grille

Technical description

Weight	8.7 kg
Fan size	420 mm
Rotor surface	Painted black
Impeller material	Sheet steel, painted black
Fan housing material	Sheet steel, galvanized and coated with black plastic (RAL 9005)
Guard grille material	Steel, coated with black plastic (RAL 9005)
Number of blades	5
Airflow direction	"V"
Direction of rotation	Counterclockwise, viewed toward rotor
Degree of protection	IP44; installation- and position-dependent as per EN 60034-5
Insulation class	"B"
Moisture (F) / Environmental (H) protection class	H0+
Max. permitted ambient temp. for motor (transport/storage)	+80 °C
Min. permitted ambient temp. for motor (transport/storage)	-40 °C
Installation position	Shaft horizontal or rotor on bottom; rotor on top on request
Condensation drainage holes	On rotor side
Mode	S1
Motor bearing	Ball bearing
Touch current according to IEC 60990 (measuring circuit Fig. 4, TN system)	< 0.75 mA
Motor protection	Thermal overload protector (TOP) internally connected
With cable	Variable
Protection class	I (with customer connection of protective earth)
Conformity with standards	EN 60335-1; CE
Approval	CSA C22.2 No. 77; UL 1004-3



AC axial fan

sickle-shaped blades (S series), single-intake

Fan housing with guard grille

Product drawing

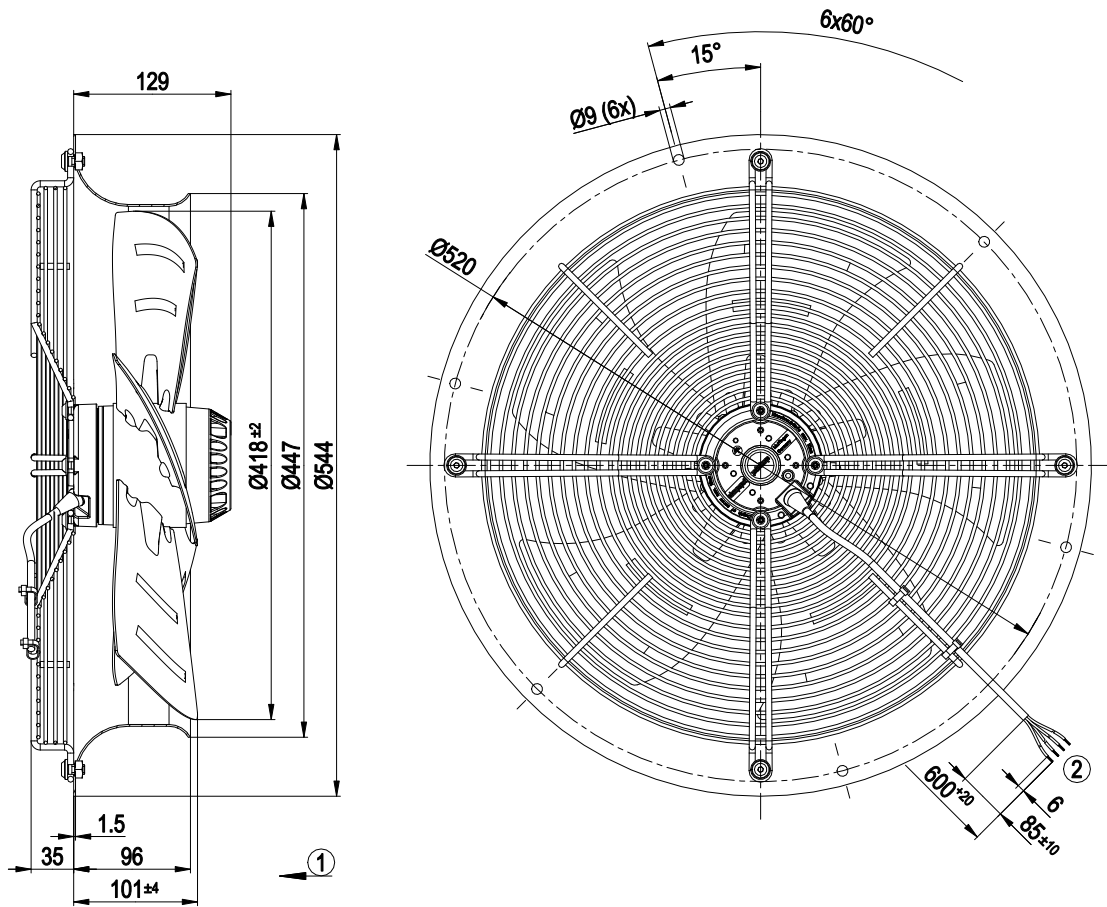

- 1 Airflow direction "V"
- 2 Cable PVC AWG20, 4x crimped splices

Connection diagram

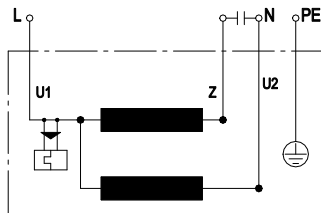

U1	blue	Z	brown	U2	black
PE	green/yellow				



AC axial fan

sickle-shaped blades (S series), single-intake

Fan housing with guard grille

Curves: Air performance 60 Hz

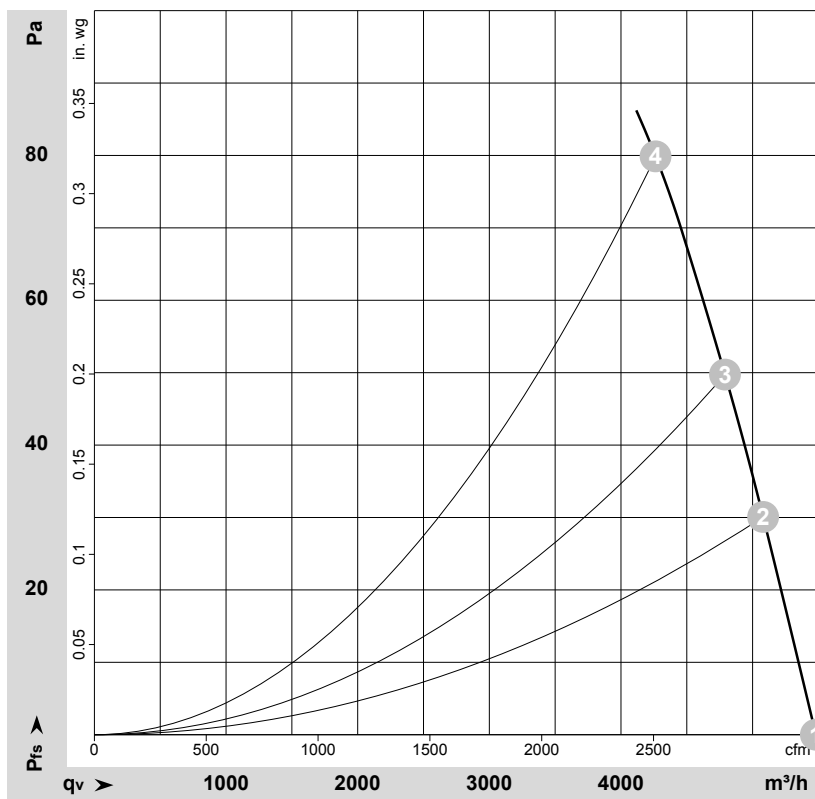

$\rho = 1.15 \text{ kg/m}^3 \pm 2 \%$

Measurement: LU-35424-1

Air performance measured according to ISO 5801 installation category A. For detailed information on the measurement setup, contact ebm-papst. Intake sound level: Sound power level according to ISO 13347 / sound pressure level measured at 1 m distance from fan axis. The values given are valid under the specified measuring conditions and may vary due to conditions of installation. For deviations from the standard configuration, the parameters have to be checked on the installed unit.

Measured values

	U	f	n	P _e	I	q _v	P _{fs}	q _v	P _{fs}
	V	Hz	min ⁻¹	W	A	m³/h	Pa	cfm	in. wg
1	115	60	1620	280	2.45	5480	0	3225	0.00
2	115	60	1610	299	2.60	5080	30	2990	0.12
3	115	60	1585	312	2.72	4790	50	2820	0.20
4	115	60	1545	331	2.88	4265	80	2510	0.32

U = Power supply · f = Frequency · n = Speed (rpm) · P_e = Power consumption · I = Current draw · q_v = Air flow · P_{fs} = Pressure increase

