

W4E400-CP14-70

AC axial fan

sickled blades (S series), single inlet
with full round nozzle

ebm-papst Mulfingen GmbH & Co. KG

Bachmühle 2 · D-74673 Mulfingen

Phone +49 7938 81-0

Fax +49 7938 81-110

sales@fansco.com

www.fansco.com

Limited partnership · Headquarters Mulfingen

County court Stuttgart · HRA 590344

General partner Elektrobau Mulfingen GmbH · Headquarters Mulfingen

County court Stuttgart · HRB 590142

Nominal data

Type	W4E400-CP14-70		
Motor	M4E074-EI		
Phase		1~	1~
Nominal voltage	VAC	115	115
Frequency	Hz	60	60
Type of data definition		fa	fa
Valid for approval / standard		CE	UL 2111
Speed	min ⁻¹	1680	1680
Power input	W	250	270
Current draw	A	2.19	
Motor capacitor	µF	20	20
Capacitor voltage	VDB	220	220
Max. back pressure	Pa	75	75
Min. ambient temperature	°C	-25	-25
Max. ambient temperature	°C	30	30

ml = Max. load · me = Max. efficiency · fa = Running at free air · cs = Customer specs · cu = Customer unit
Subject to alterations



AC axial fan

sickled blades (S series), single inlet
with full round nozzle

Technical features

Mass	8.17 kg
Size	400 mm
Surface of rotor	Coated in black
Material of impeller	Sheet steel, coated in black
Material of wall ring	Sheet steel, galvanised and coated in black plastic (RAL 9005)
Material of guard grille	Steel, coated in black plastic (RAL9005)
Direction of air flow	"V"
Direction of rotation	Counter-clockwise, seen on rotor
Type of protection	IP 44; Depending on installation and position as per EN 60034-5
Insulation class	"B"
Humidity class	F1-2
Max. permissible ambient motor temp. (transp./ storage)	+ 80 °C
Min. permissible ambient motor temp. (transp./storage)	- 40 °C
Mounting position	Shaft horizontal or rotor on bottom; rotor on top on request
Condensate discharge holes	Rotor-side
Operation mode	S1
Motor bearing	Ball bearing
Touch current acc. IEC 60990 (measuring network Fig. 4, TN system)	< 0.75 mA
Motor protection	Thermal overload protector (TOP) wired internally
Cable exit	Variable
Protection class	I (if protective earth is connected by customer)
Product conforming to standard	EN 60335-1; CE
Approval	UL 2111; CSA C22.2 Nr.77



AC axial fan

sickled blades (S series), single inlet
with full round nozzle

Product drawing

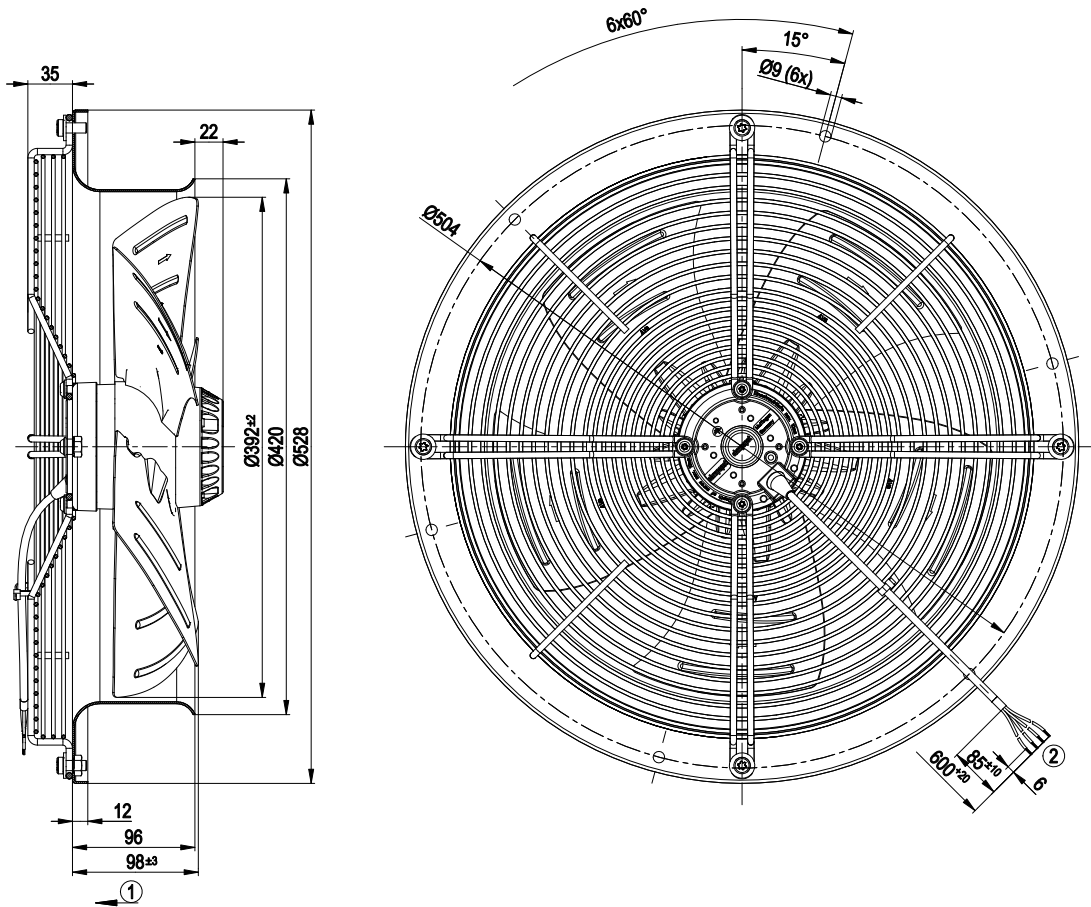

- 1 Direction of air flow "V"
- 2 Connection line PVC AWG20, 4x lead tips crimped

Connection screen

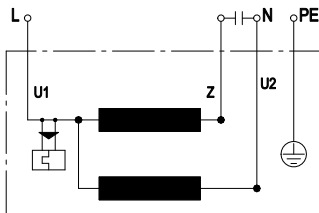

U1	blue	Z	brown	U2	black
PE	green/yellow				



AC axial fan

sickled blades (S series), single inlet
with full round nozzle

Charts: Air flow 60 Hz

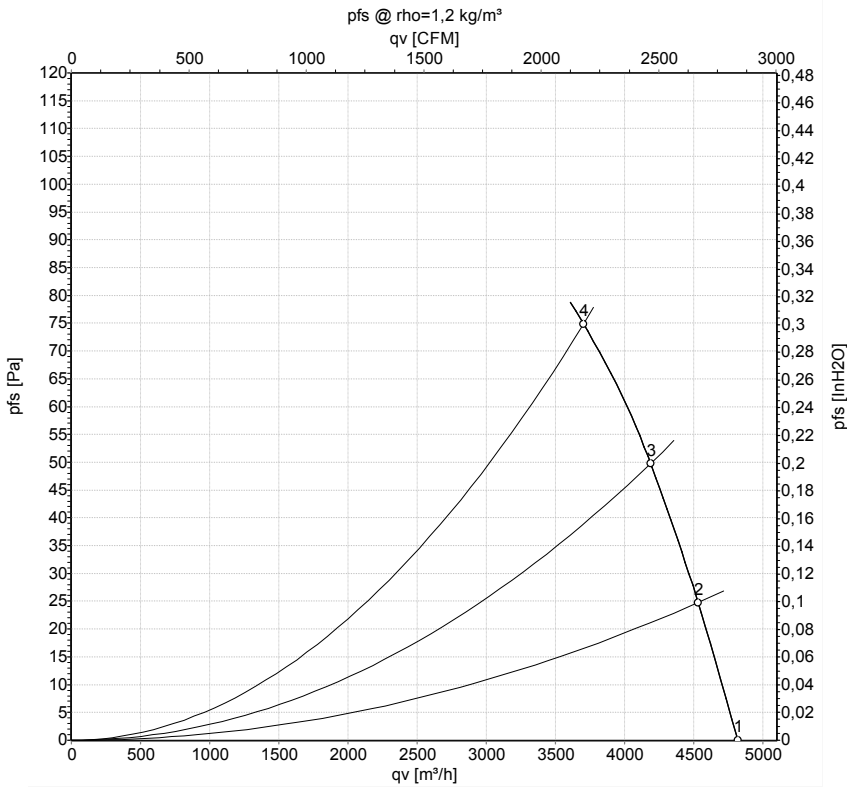

Measurement: LU-33656

Air performance measured as per ISO 5801 Installation category A. For detailed information on the measuring set-up, please contact ebm-papst. Suction-side noise levels: L_{wA} measured as per ISO 13347 / L_{pA} measured with 1m distance to fan axis. The values given are valid under the measuring conditions mentioned above and may vary according to the actual installation situation. With any deviation from the standard set-up, the specific values have to be checked and reviewed with the unit installed.

Measured values

	U	f	n	P _e	I	qv	p _{fs}
	V	Hz	min ⁻¹	W	A	m ³ /h	Pa
1	115	60	1680	250	2.19	4820	0
2	115	60	1660	264	2.30	4530	25
3	115	60	1630	279	2.43	4190	50
4	115	60	1580	297	2.61	3705	75

U = Supply voltage · f = Frequency · n = Speed · P_e = Power input · I = Current draw · qv = Air flow · p_{fs} = Pressure increase

