

AC axial fan

sickled blades (S series)

with full round nozzle

ebm-papst Mulfingen GmbH & Co. KG

Bachmühle 2 · D-74673 Mulfingen

Phone +49 7938 81-0

Fax +49 7938 81-110

sales@fansco.com

www.fansco.com

Limited partnership · Headquarters Mulfingen
County court Stuttgart · HRA 590344

General partner Elektrobau Mulfingen GmbH · Headquarters Mulfingen
County court Stuttgart · HRB 590142

Nominal data

Type	W4E250-CH02-70					
Motor	M4E068-BF					
Phase		1~	1~	1~	1~	1~
Nominal voltage	VAC	230	230	230	230	230
Frequency	Hz	50	50	60	60	60
Type of data definition		fa	fa	fa	fa	fa
Valid for approval / standard		CE	CE	UL 2111	CE	CE
Speed	min ⁻¹	1400	1350	1640	1640	1570
Power input	W	42	45	48	44	50
Current draw	A	0.20	0.22	0.22	0.20	0.23
Motor capacitor	µF	1.5	1.5	1.5	1.5	1.5
Capacitor voltage	VDB	400	400	400	400	400
Max. back pressure	Pa	20	35	27	27	50
Max. ambient temperature	°C	40	40	60	60	60
Starting current	A	0.33	0.33	0.34	0.33	0.33

ml = max. load · me = max. efficiency · fa = running at free air · cs = customer specs · cu = customer unit
Subject to alterations



AC axial fan

sickled blades (S series)

with full round nozzle

Technical features

Mass	2.79 kg
Size	250 mm
Surface of rotor	Coated in black
Material of blades	Sheet steel, coated in black
Material of wall ring	Sheet steel, pre-galvanised and coated in black plastic
Material of guard grille	Steel, phosphated and coated in black plastic
Number of blades	7
Direction of air flow	"V"
Direction of rotation	Counter-clockwise, seen on rotor
Type of protection	IP 44; Depending on installation and position as per EN 60034-5
Insulation class	"B"
Humidity class	F5
Max. permissible ambient motor temp. (transp./ storage)	+ 80 °C
Min. permissible ambient motor temp. (transp./storage)	- 40 °C
Mounting position	Shaft horizontal or rotor on bottom; rotor on top on request
Condensate discharge holes	Rotor-side
Operation mode	S1
Motor bearing	Ball bearing
Touch current acc. IEC 60990 (measuring network Fig. 4, TN system)	< 0.75 mA
Motor protection	Thermal overload protector (TOP) wired internally
Cable exit	Variable
Protection class	I (if protective earth is connected by customer)
Product conforming to standard	EN 60335-1
Approval	UL 2111; CSA C22.2 Nr.77



AC axial fan

sickled blades (S series)
with full round nozzle

Product drawing

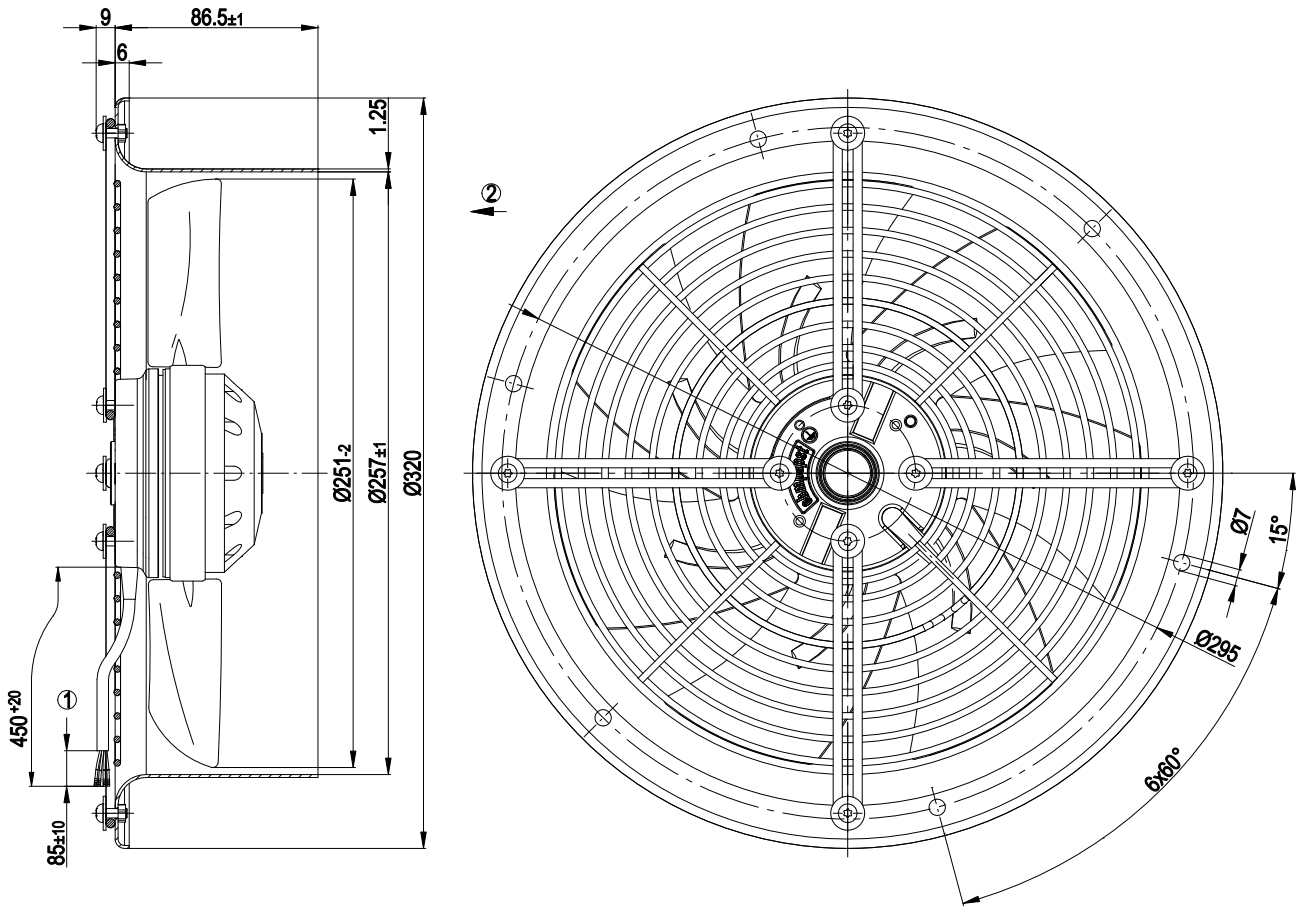

- 1 Connection line PVC, 4x brass lead tips crimped
- 2 Direction of air flow "V"

Connection screen

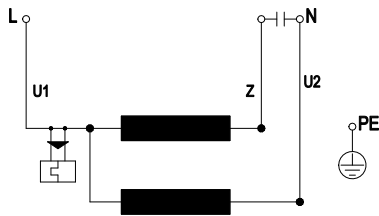

U1	blue	Z	brown	U2	black
PE	green/yellow				



AC axial fan

sickled blades (S series)
with full round nozzle

Charts: Air flow 50 Hz

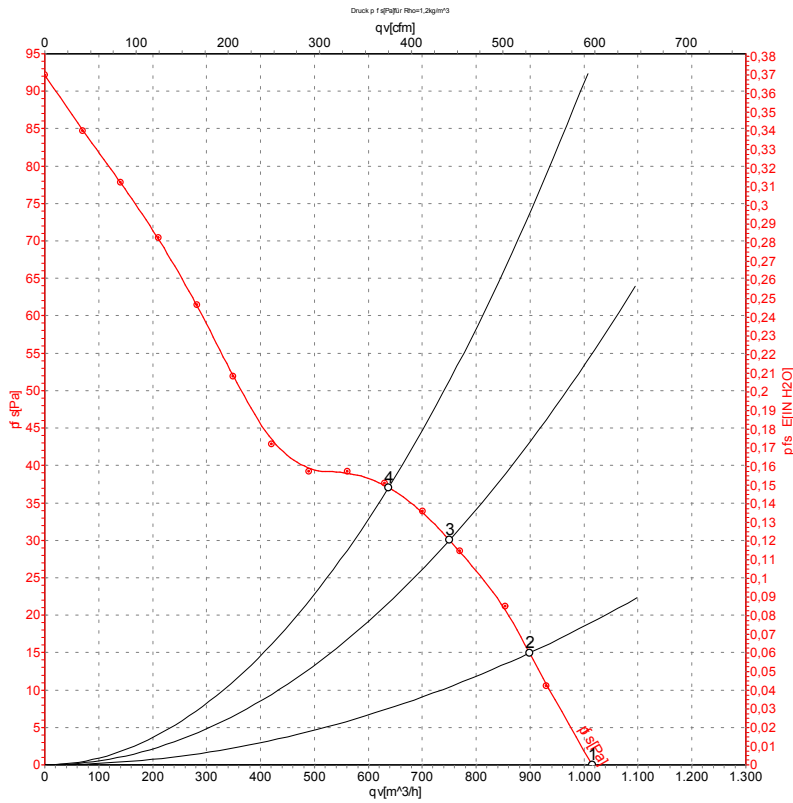

Measurement: LU-60036

Air performance measured as per ISO 5801 Installation category A. For detailed information on the measuring set-up, please contact ebm-papst. Suction-side noise levels: LwA measured as per ISO 13347 / LpA measured with 1m distance to fan axis. The values given are valid under the measuring conditions mentioned above and may vary according to the actual installation situation. With any deviation from the standard set-up, the specific values have to be checked and reviewed with the unit installed.

Measured values

	U	f	n	P _e	I	qv	P _{fs}
	V	Hz	min ⁻¹	W	A	m ³ /h	Pa
1	230	50	1400	42	0.19	1015	0
2	230	50	1385	43	0.20	900	15
3	230	50	1370	44	0.20	750	30
4	230	50	1350	45	0.22	640	35

U = Supply voltage · f = Frequency · n = Speed · P_e = Power input · I = Current draw · qv = Air flow · P_{fs} = Pressure increase



AC axial fan

sickled blades (S series)
with full round nozzle

Charts: Air flow 60 Hz

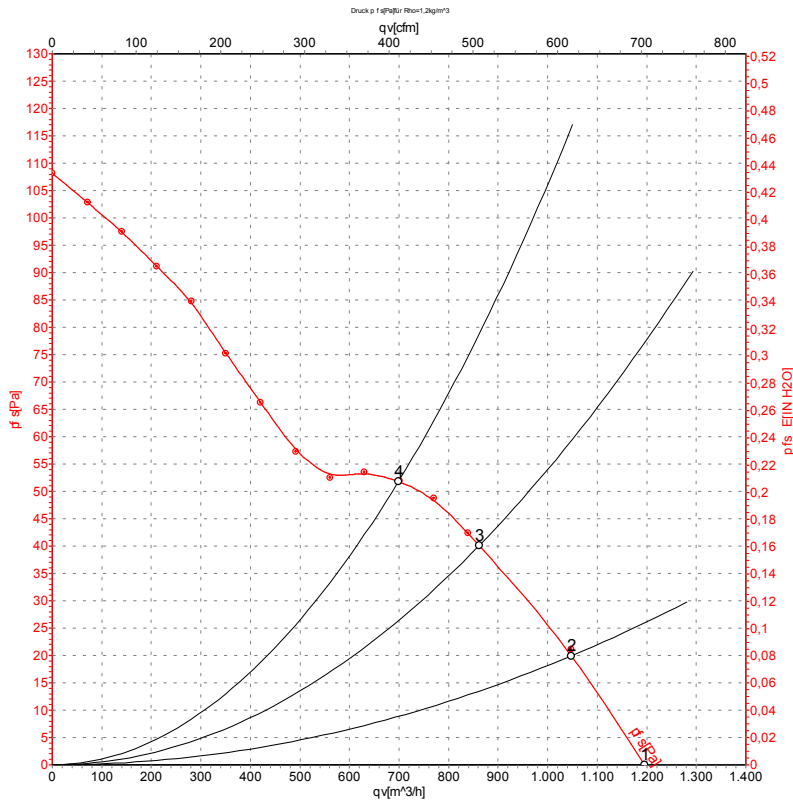

Measurement: LU-60037

Air performance measured as per ISO 5801 Installation category A. For detailed information on the measuring set-up, please contact ebm-papst. Suction-side noise levels: LwA measured as per ISO 13347 / LpA measured with 1m distance to fan axis. The values given are valid under the measuring conditions mentioned above and may vary according to the actual installation situation. With any deviation from the standard set-up, the specific values have to be checked and reviewed with the unit installed.

Measured values

	U	f	n	Pe	I	qv	Pfs
	V	Hz	min ⁻¹	W	A	m ³ /h	Pa
1	230	60	1630	45	0.20	1200	0
2	230	60	1625	47	0.21	1045	20
3	230	60	1570	49	0.21	860	40
4	230	60	1570	50	0.23	700	50

U = Supply voltage · f = Frequency · n = Speed · Pe = Power input · I = Current draw · qv = Air flow · Pfs = Pressure increase

