

EC axial fan - HyBlade

sickle-shaped blades (S series)

Duct fan

ebm-papst Mulfingen GmbH & Co. KG

Bachmühle 2 · D-74673 Mulfingen

Phone +49 7938 81-0

Fax +49 7938 81-110

sales@fansco.com

www.fansco.com

Limited partnership · Headquarters Mulfingen

Amtsgericht (court of registration) Stuttgart · HRA 590344

General partner Elektrobau Mulfingen GmbH · Headquarters Mulfingen

Amtsgericht (court of registration) Stuttgart · HRB 590142

Nominal data

Type	W3G450-IL03-H4	
Motor	M3G084-FA	
Phase		1~
Nominal voltage	VAC	230
Nominal voltage range	VAC	200 .. 277
Frequency	Hz	50/60
Method of obtaining data		ml
Speed (rpm)	min ⁻¹	1500
Power consumption	W	500
Current draw	A	2.2
Max. back pressure	Pa	140
Max. back pressure	in. wg	0.56
Min. ambient temperature	°C	-25
Max. ambient temperature	°C	60

ml = Max. load · me = Max. efficiency · fa = Free air · cs = Customer specification · ce = Customer equipment
Subject to change

Data according to Commission Regulation (EU) 327/2011 (EN 17166)

		Actual	Req. 2015			
01 Overall efficiency η_{es}	%	34.4	31.9	09 Power consumption P_{ed}	kW	0.52
02 Measurement category		A		09 Air flow q_v	m ³ /h	4505
03 Efficiency category		Static		09 Pressure increase p_{fs}	Pa	130
04 Efficiency grade N		42.5	40	10 Speed (rpm) n	min ⁻¹	1495
05 Variable speed drive		Yes		11 Specific ratio*		1.00

Data obtained at optimum efficiency level.
The ErP data is determined using a motor-impeller combination in a standardized measurement setup.

* Specific ratio = $1 + p_s / 100\,000\text{ Pa}$

LU-202105



Technical description

Weight	10 kg
Size	450 mm
Motor size	84
Rotor surface	Painted black
Electronics housing material	Die-cast aluminum, painted black
Impeller material	PP plastic
Support ring material	Steel, galvanized and coated with black plastic (RAL 9005)
Fan housing material	Sheet steel, galvanized and coated with black plastic (RAL 9005)
Number of blades	5
Blade pitch	0°
Airflow direction	A
Direction of rotation	Clockwise, viewed toward rotor
Degree of protection	IP55
Insulation class	"F"
Moisture (F) / Environmental (H) protection class	H2
Max. permitted ambient temp. for motor (transport/storage)	+80 °C
Min. permitted ambient temp. for motor (transport/storage)	-40 °C
Installation position	Shaft horizontal or rotor on top; rotor on bottom on request
Condensation drainage holes	None
Mode	S1
Motor bearing	Ball bearing
Technical features	<ul style="list-style-type: none"> - Output 10 VDC, max. 10 mA - Operation and alarm display - Alarm relay - Integrated PID controller - Power limiter - Motor current limitation - PFC, active - RS-485 MODBUS-RTU - Soft start - Control input 0-10 VDC / PWM - Control interface with SELV potential safely disconnected from the mains - Thermal overload protection for electronics/motor - Line undervoltage / phase failure detection
Touch current according to IEC 60990 (measuring circuit Fig. 4, TN system)	<= 3.5 mA
Electrical hookup	Terminal box
Motor protection	Thermal overload protector (TOP) internally connected
With cable	Variable
Protection class	I (with customer connection of protective earth)
Conformity with standards	EN 61800-5-1; CE
Approval	UL 1004-7 + 60730-1; EAC; CSA C22.2 No. 77 + CAN/CSA-E60730-1

EC axial fan - HyBlade

sickle-shaped blades (S series)

Duct fan

Product drawing

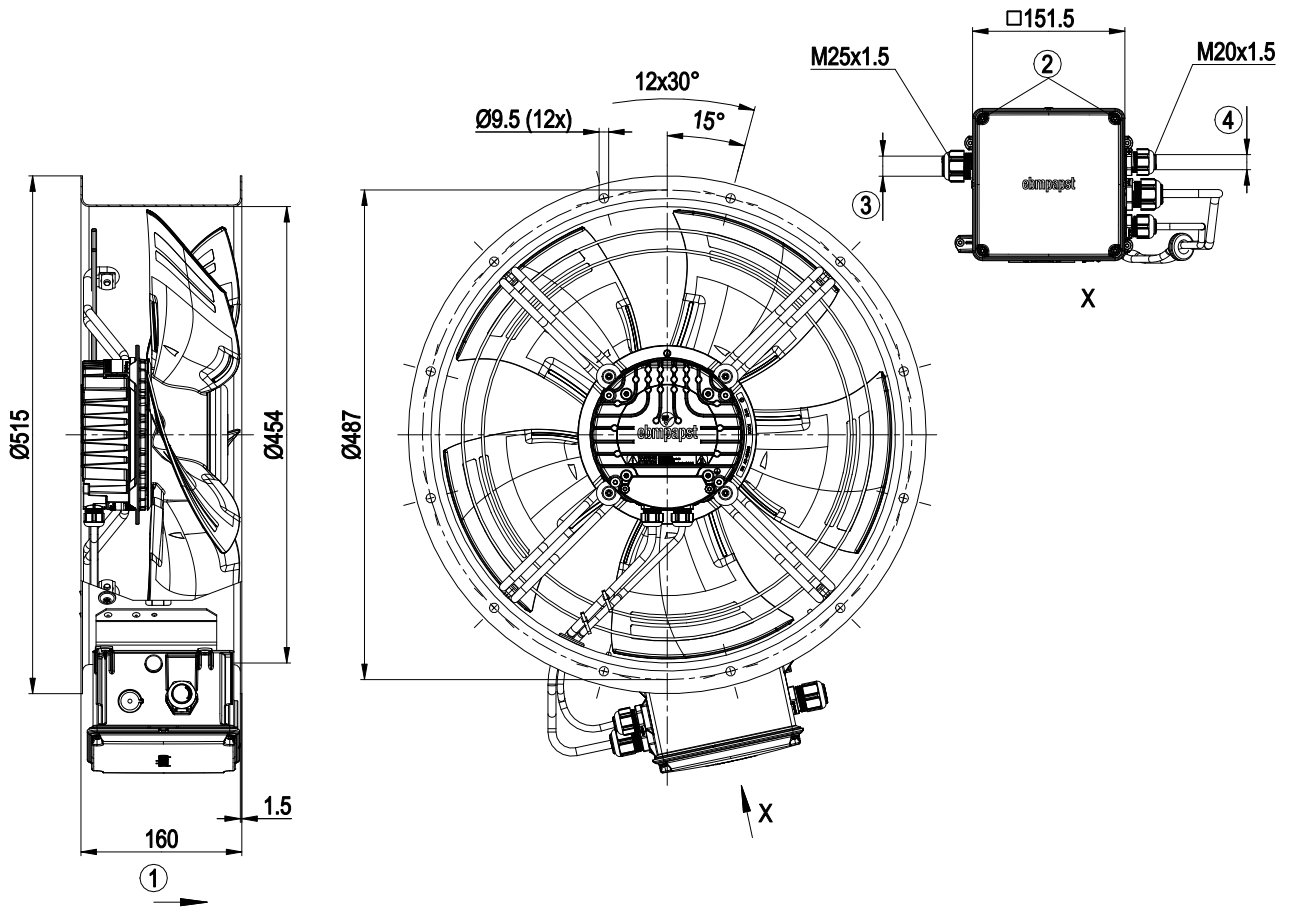

1	Direction of air flow "A"
2	Tightening torque 1.8 ± 0.3 Nm
3	Cable diameter min. 9 mm, max. 16 mm, tightening torque 2.5 ± 0.4 Nm
4	Cable diameter min. 4 mm, max. 10 mm, tightening torque 2.5 ± 0.4 Nm



Connection diagram

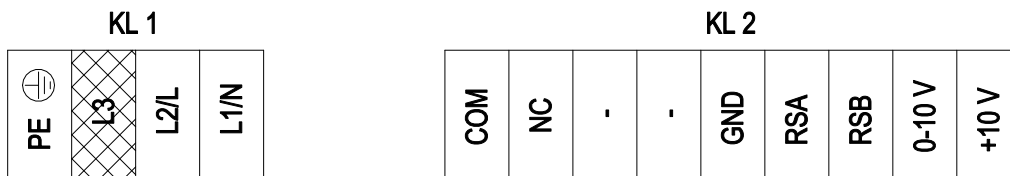

— shaded gray => terminals not used

No.	Conn.	Designation	Color	Function/assignment
1		PE	green/yellow	Protective earth
1		L3	-	not used
1		L2/L	blue	Power supply, phase
1		L1/N	black 1	Power supply, neutral conductor
2		COM	white 2	Status relay, floating status contact, common connection, contact rating 250 VAC / 2 A (AC1) / min. 10 mA; basic insulation on supply side and reinforced insulation on control interface side
2		NC	white 1	Status relay, floating status contact, break for failure, contact rating 250 VAC / 2 A (AC1) / min. 10 mA; basic insulation on supply side and reinforced insulation on control interface side
2		-	-	not used
2		-	-	not used
2		GND	blue	Reference ground for control interface, SELV
2		RSA	white	RS485 interface for MODBUS, RSA; SELV
2		RSB	brown	RS485 interface for MODBUS, RSB; SELV
2		0-10 V	yellow	Analog input (set value) SELV, 0-10 V, Ri = 100 kΩ, adjustable curve
2		+10 V	red	Fixed voltage output 10 VDC, SELV, +10 V +/-3%, max. 10 mA, short-circuit-proof, power supply for external devices (e.g. potentiometers)

Curves: Air performance 50 Hz

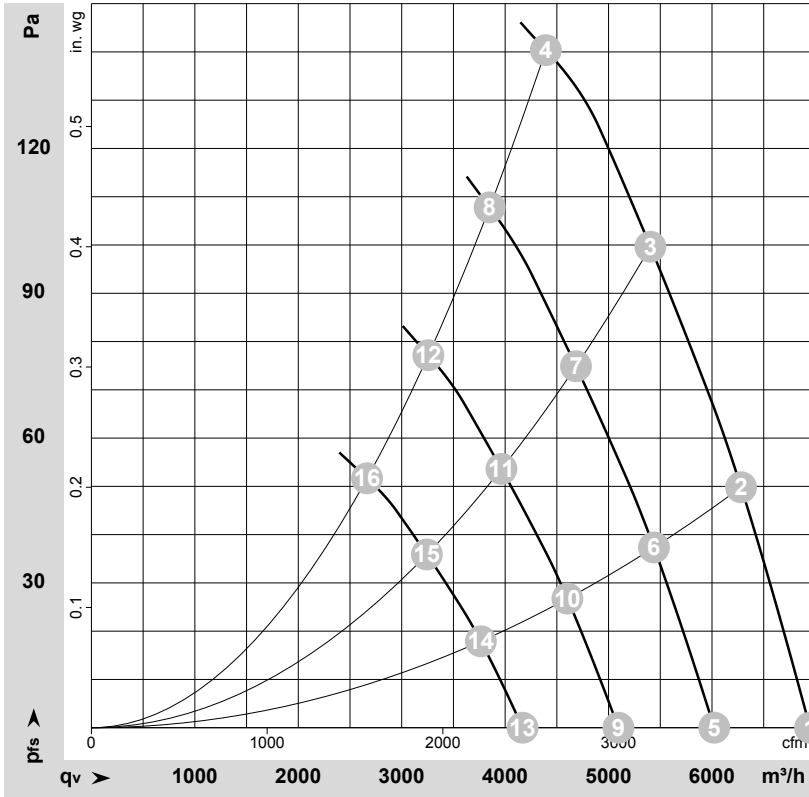

$\rho = 1.15 \text{ kg/m}^3 \pm 2 \%$

Measurement: LU-191218-1

Air performance measured according to ISO 5801 installation category A. For detailed information on the measurement setup, contact ebmpapst. Intake sound level: Sound power level according to ISO 13347 / sound pressure level measured at 1 m distance from fan axis. The values given are valid under the specified measuring conditions and may vary due to conditions of installation. For deviations from the standard configuration, the parameters have to be checked on the installed unit.

Measured values

	Wired	U	f	n	P _{ed}	I	LpA _{in}	LwA _{in}	LwA _{out}	q _v	P _{fs}	q _v	P _{fs}
		V	Hz	min ⁻¹	W	A	dB(A)	dB(A)	dB(A)	m ³ /h	Pa	cfm	in. wg
1	1~	230	50	1500	416	1.83	77	85	85	6950	0	4090	0.00
2	1~	230	50	1500	453	1.98	76	84	84	6280	50	3695	0.20
3	1~	230	50	1500	494	2.16	75	82	83	5405	100	3180	0.40
4	1~	230	50	1500	500	2.20	73	81	82	4395	140	2585	0.56
5	1~	230	50	1300	271	1.19	73	81	82	6020	0	3545	0.00
6	1~	230	50	1300	294	1.29	72	80	81	5440	39	3200	0.16
7	1~	230	50	1300	322	1.41	71	79	79	4685	75	2755	0.30
8	1~	230	50	1300	350	1.53	70	78	78	3850	108	2265	0.43
9	1~	230	50	1100	164	0.72	69	77	77	5095	0	3000	0.00
10	1~	230	50	1100	178	0.78	68	76	76	4600	28	2710	0.11
11	1~	230	50	1100	195	0.85	67	75	75	3965	54	2335	0.22
12	1~	230	50	1100	212	0.93	66	73	74	3255	77	1915	0.31
13	1~	230	50	900	90	0.39	64	72	72	4170	0	2455	0.00
14	1~	230	50	900	97	0.43	63	71	71	3765	18	2215	0.07
15	1~	230	50	900	107	0.47	62	70	70	3245	36	1910	0.14
16	1~	230	50	900	116	0.51	61	68	69	2665	52	1570	0.21

Wired = Wiring · U = Voltage · f = Frequency · n = Speed (rpm) · P_{ed} = Power consumption · I = Current draw · LpA_{in} = Sound pressure level intake side · LwA_{in} = Sound power level intake side
 LwA_{out} = Sound power level outlet side · q_v = Air flow · P_{fs} = Pressure increase

