

EC axial fan

with brushless DC motor

Fan housing with guide vanes, Automotive

ebm-papst Mulfingen GmbH & Co. KG

Bachmühle 2 · D-74673 Mulfingen

Phone +49 7938 81-0

Fax +49 7938 81-110

sales@fansco.com

www.fansco.com

Limited partnership · Headquarters Mulfingen

Amtsgericht (court of registration) Stuttgart · HRA 590344

General partner Elektrobau Mulfingen GmbH · Headquarters Mulfingen

Amtsgericht (court of registration) Stuttgart · HRB 590142

Nominal data

Type	W3G300-ME48-11	
Motor	M3G084-BF	
Nominal voltage	VDC	26
Nominal voltage range	VDC	16 .. 32
Method of obtaining data		fa
Status		prelim.
Speed (rpm)	min ⁻¹	3650
Power consumption	W	320
Current draw	A	12.4
Min. ambient temperature	°C	-40
Max. ambient temperature	°C	70
-with power derating to	°C	85

ml = Max. load · me = Max. efficiency · fa = Free air · cs = Customer specification · ce = Customer equipment
Subject to change

Data according to Commission Regulation (EU) 327/2011

		Actual	Req. 2015
01 Overall efficiency η_{es}	%	54.4	30.9
02 Measurement category		A	
03 Efficiency category		Static	
04 Efficiency grade N		63.5	40
05 Variable speed drive		Yes	

Data obtained at optimum efficiency level.

The ErP data is determined using a motor-impeller combination in a standardized measurement setup.

09 Power consumption P_e	kW	0.36
09 Air flow q_v	m ³ /h	1930
09 Pressure increase p_{fs}	Pa	331
10 Speed (rpm) n	min ⁻¹	3595
11 Specific ratio*		1.00

* Specific ratio = $1 + p_{fs} / 100\,000\text{ Pa}$

LU-199780



EC axial fan

with brushless DC motor

Fan housing with guide vanes, Automotive

Technical description

Weight	2 kg
Size	300 mm
Motor size	84
Blade material	PA plastic
Fan housing material	PP plastic
Number of blades	7
Airflow direction	V
Balancing grade according to DIN ISO 1940-1	G 16
Direction of rotation	Clockwise, viewed toward rotor
Degree of protection	Motor IP24 KM, electronics IP6K9K (mating connector installed)
Insulation class	"B"
Moisture (F) / Environmental (H) protection class	H4
Ambient temperature note	Over +70°C with power derating; Occasional start-up between -40°C and -25°C is permitted. For continuous operation at ambient temperatures below -25°C (such as refrigeration applications), a fan design with special low-temperature bearings must be used.
Max. permitted ambient temp. for motor (transport/storage)	+85 °C
Min. permitted ambient temp. for motor (transport/storage)	-40 °C
Installation position	Any
Mode	S1
Motor bearing	Ball bearing; (sealed)
Life expectancy	40,000 h (typical)
Technical features	<ul style="list-style-type: none"> - Fault output (open collector) - Power limiter - Load dump (58 V) - Motor current limitation - Soft start - Control input 0-10 VDC / PWM - Temperature derating - Thermal overload protection for electronics - Reverse polarity protection
Electrical hookup	Plug; Standby current less than 500 µA
Approval	EAC



EC axial fan

with brushless DC motor

Fan housing with guide vanes, Automotive

Product drawing

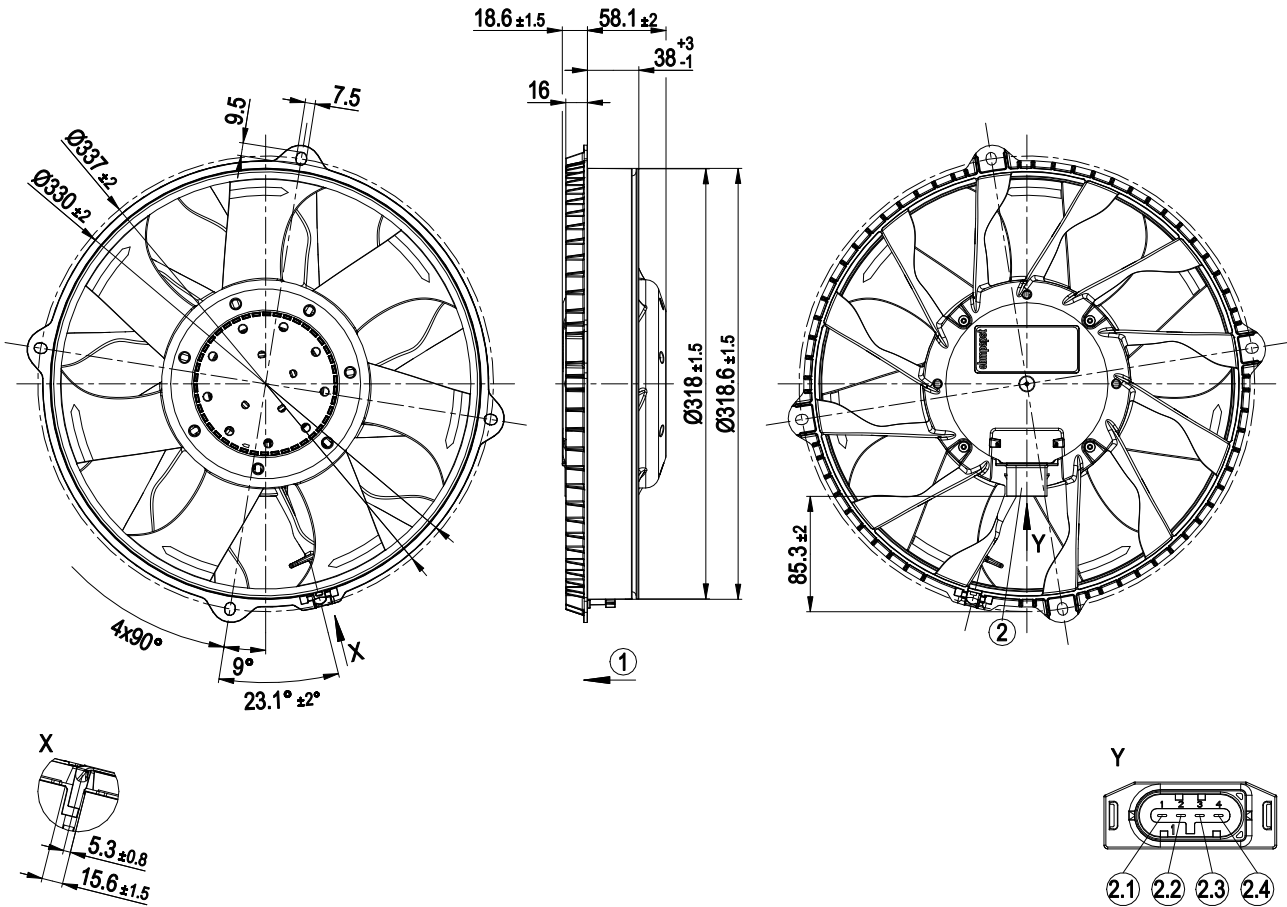

1	Airflow direction "V"
2	4-pole plug, pluggable with cable from accessories
2.1	Diagnostic output
2.2	PWM/LIN
2.3	+ UB
2.4	GND
Accessory part: Cable (460 mm) with mating connector, part no. 02040-4-1021 not included in scope of delivery 4-pole mating connector TE 1-1718628-1, 2x plug contact TE 1-968857-1, 2x plug contact TE 1-968855-1, 2x seal TE 828905-1, 2x seal TE 828904-1	



EC axial fan

with brushless DC motor

Fan housing with guide vanes, Automotive

Connection diagram

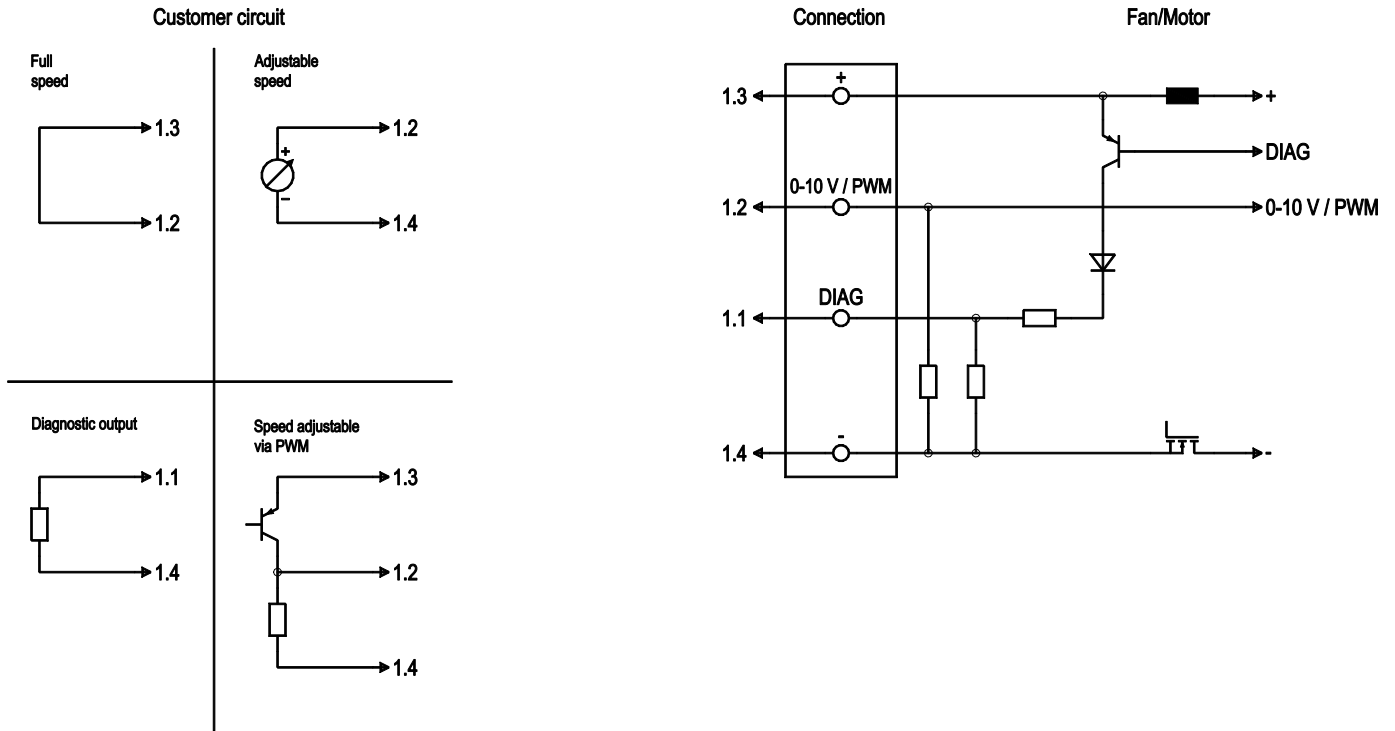

No.	Conn.	Designation	Function/assignment
	1.3	+	Power supply +
	1.4	-	Power supply -
	1.2	0-10 V / PWM	Control input: $R_i > 27\text{ k}\Omega$ 0-10 V: (typ. 0.5 V -> Standby; 1.5 V -> n = min.; 9.5 V -> n = max.) or PWM: (12 V - U_b ; 1 kHz - 10 kHz; typ. < 1% -> standby; 10% -> n = min.; 95% -> n = max.)
	1.1	DIAG	Diagnostic output: Open Collector, $I_{source\ max} = 10\text{ mA}$, $R_{source} = 2\text{ k}\Omega$; $R_{sink} = 100\text{ k}\Omega$ fan OK -> low; fan error -> high



EC axial fan

with brushless DC motor

Fan housing with guide vanes, Automotive

Curves: Air performance

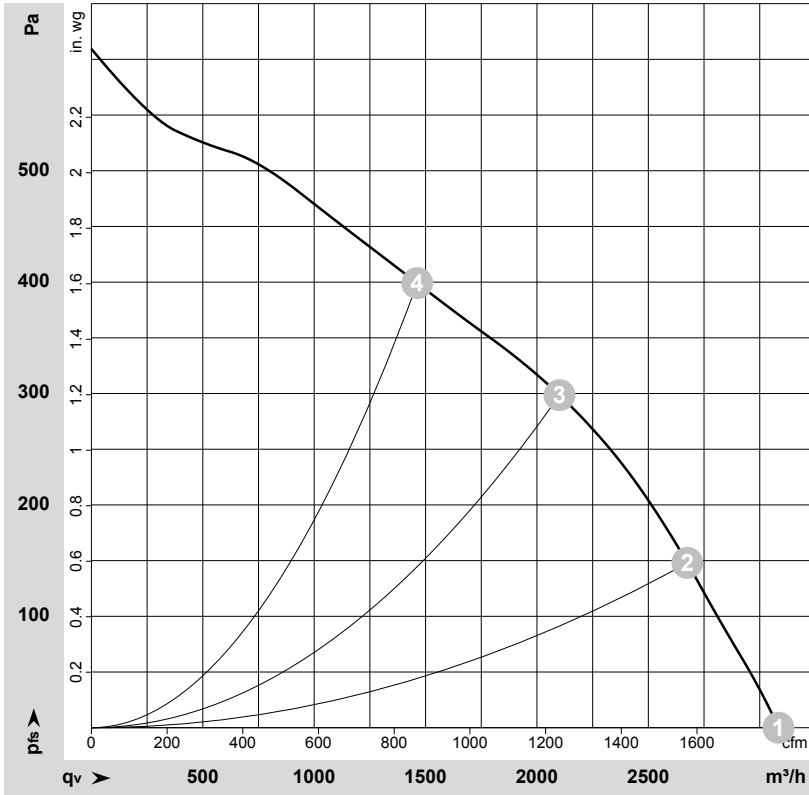

$\rho = 1.15 \text{ kg/m}^3 \pm 2 \%$

Measurement: LU-199780-1

Air performance measured according to ISO 5801 installation category A. For detailed information on the measurement setup, contact ebmpapst. Intake sound level: Sound power level according to ISO 13347 / sound pressure level measured at 1 m distance from fan axis. The values given are valid under the specified measuring conditions and may vary due to conditions of installation. For deviations from the standard configuration, the parameters have to be checked on the installed unit.

Measured values

	U	n	P _{ed}	I	LpA _{in}	LwA _{in}	q _v	p _{fs}	q _v	p _{fs}
	V	min ⁻¹	W	A	dB(A)	dB(A)	m ³ /h	Pa	cfm	in. wg
1	26	3650	320	12.40	80	88	3085	0	1815	0.00
2	26	3650	347	13.33	79	87	2675	150	1575	0.60
3	26	3650	365	14.03	81	88	2100	300	1235	1.20
4	26	3650	376	14.46	84	91	1465	400	860	1.61

U = Voltage · n = Speed (rpm) · P_{ed} = Power consumption · I = Current draw · LpA_{in} = Sound pressure level intake side · LwA_{in} = Sound power level intake side · q_v = Air flow
 p_{fs} = Pressure increase

