

**ebm-papst Mulfingen GmbH & Co. KG**

Bachmühle 2 · D-74673 Mulfingen

Phone +49 7938 81-0

Fax +49 7938 81-110

sales@fansco.com

www.fansco.com

Limited partnership · Headquarters Mulfingen

Amtsgericht (court of registration) Stuttgart · HRA 590344

General partner Elektrobau Mulfingen GmbH · Headquarters Mulfingen

Amtsgericht (court of registration) Stuttgart · HRB 590142

**Nominal data**

<b>Type</b>	<b>W2S130-AA19-38</b>		
<b>Motor</b>	<b>M2S052-CA</b>		
Phase		2~	2~
Nominal voltage	VAC	400	400
Frequency	Hz	50	60
Method of obtaining data		fa	fa
Valid for approval/standard		CE	CE
Speed (rpm)	min <sup>-1</sup>	2800	3200
Power consumption	W	41	38
Current draw	A	0.16	0.13
Max. back pressure	Pa	80	120
Max. back pressure	inH <sub>2</sub> O	0.32	0.48
Min. ambient temperature	°C	-25	-25
Max. ambient temperature	°C	50	70
Starting current	A	0.25	0.21

ml = Max. load · me = Max. efficiency · fa = Free air · cs = Customer specification · ce = Customer equipment

Subject to change



### Technical description

<b>Weight</b>	1.1 kg
<b>Fan size</b>	130 mm
<b>Rotor surface</b>	Painted black
<b>Blade material</b>	Sheet steel, painted black
<b>Fan housing material</b>	Die-cast aluminum, painted black
<b>Number of blades</b>	7
<b>Airflow direction</b>	"V"
<b>Direction of rotation</b>	Counterclockwise, viewed toward rotor
<b>Degree of protection</b>	IP20
<b>Insulation class</b>	"B"
<b>Max. permitted ambient temp. for motor (transport/storage)</b>	+ 80 °C
<b>Min. permitted ambient temp. for motor (transport/storage)</b>	- 40 °C
<b>Installation position</b>	Any
<b>Condensation drainage holes</b>	None, open rotor
<b>Mode</b>	S1
<b>Motor bearing</b>	Ball bearing
<b>Touch current according to IEC 60990 (measuring circuit Fig. 4, TN system)</b>	< 0.75 mA
<b>Motor protection</b>	Thermal overload protector (TOP) internally connected
<b>Protection class</b>	I (if protective earth is connected by customer to the housing's connection point)
<b>Conformity with standards</b>	EN 60335-1; CE



## Product drawing

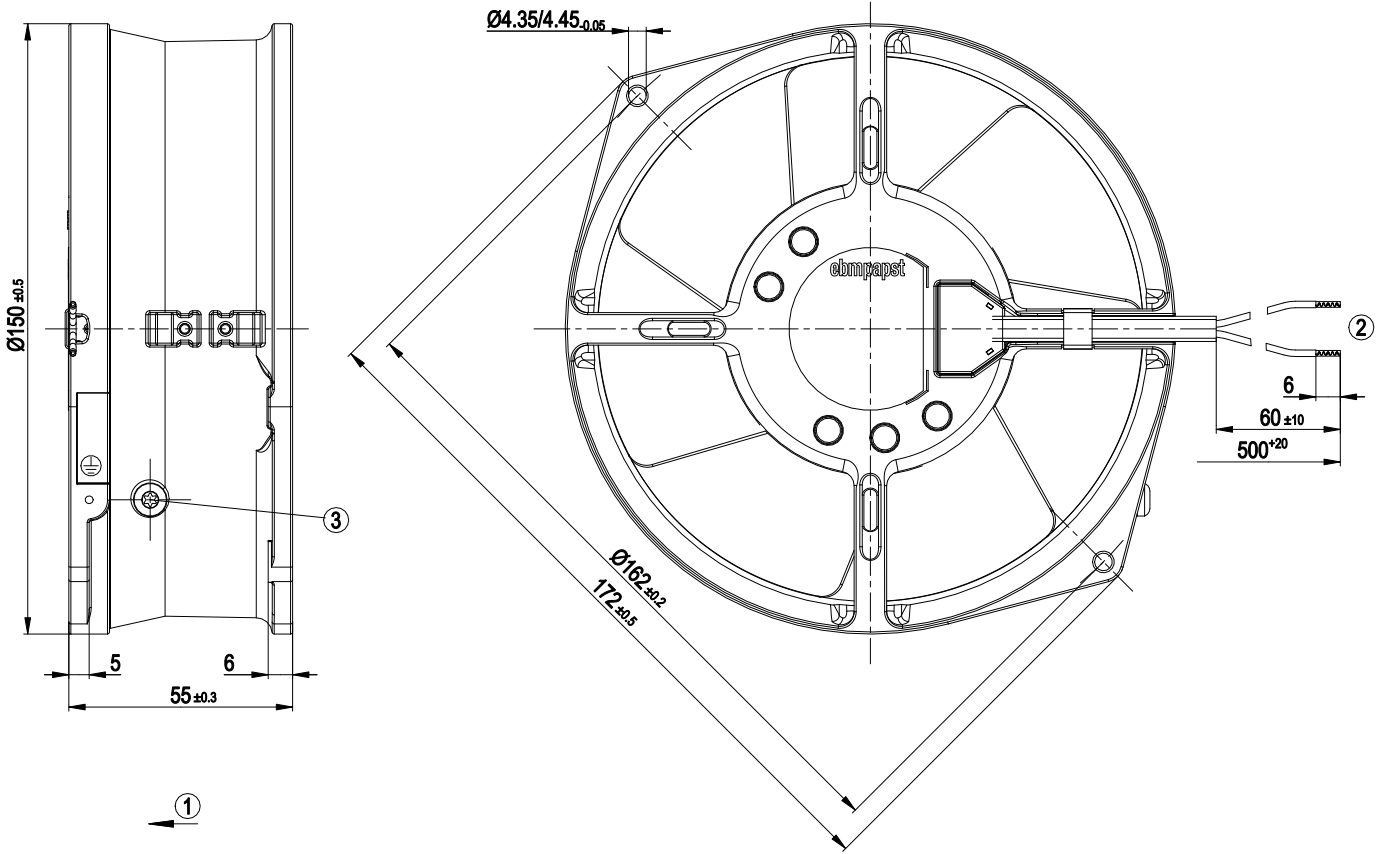

1	Direction of air flow "V"
2	Cable PVC 2x 0.5 mm <sup>2</sup> , 2x crimped splices
3	M4 screw for fastening ground connector

## Connection diagram

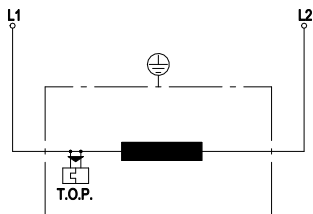

L1	blue
L2	brown
TOP	Thermal overload protector



## Curves: Air performance 50 Hz

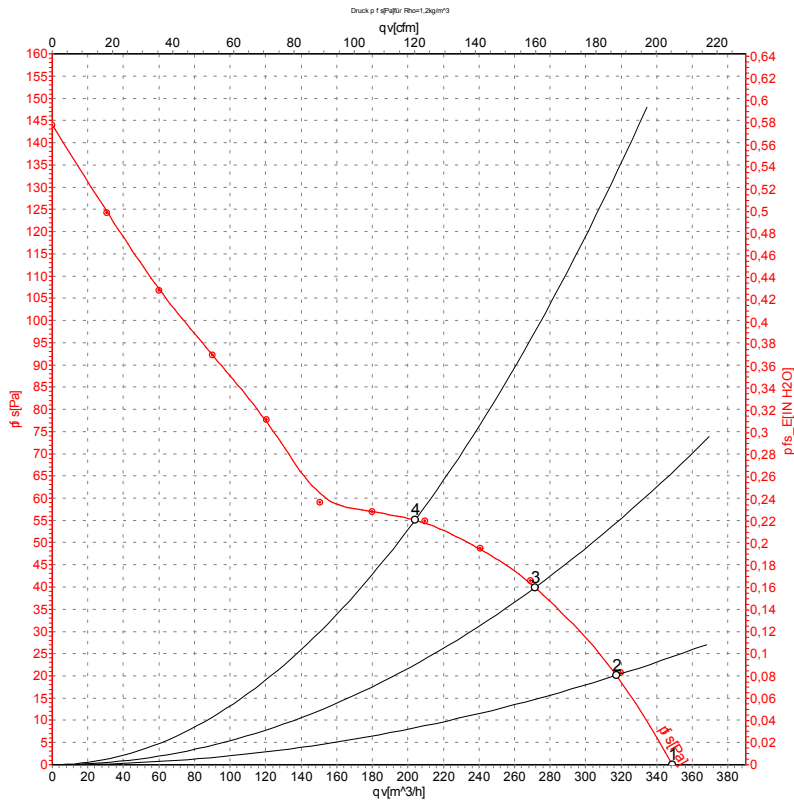

Measurement: LU-69605-1

Air performance measured according to ISO 5801 installation category A. For detailed information on the measurement setup, contact ebmpapst. Intake sound level: Sound power level according to ISO 13347 / sound pressure level measured at 1 m distance from fan axis. The values given are valid under the specified measuring conditions and may vary due to conditions of installation. For deviations from the standard configuration, the parameters have to be checked on the installed unit.

## Measured values

	U	f	n	P <sub>e</sub>	I	qv	p <sub>fs</sub>	qv	p <sub>fs</sub>
	V	Hz	min <sup>-1</sup>	W	A	m <sup>3</sup> /h	Pa	CFM	inH2O
1	400	50	2800	41	0.16	350	0	205	0.00
2	400	50	2755	43	0.16	315	20	185	0.08
3	400	50	2740	44	0.16	270	40	160	0.16
4	400	50	2745	43	0.16	205	55	120	0.22

U = Power supply · f = Frequency · n = Speed (rpm) · P<sub>e</sub> = Power consumption · I = Current draw · qv = Air flow · p<sub>fs</sub> = Pressure increase



## Curves: Air performance 60 Hz

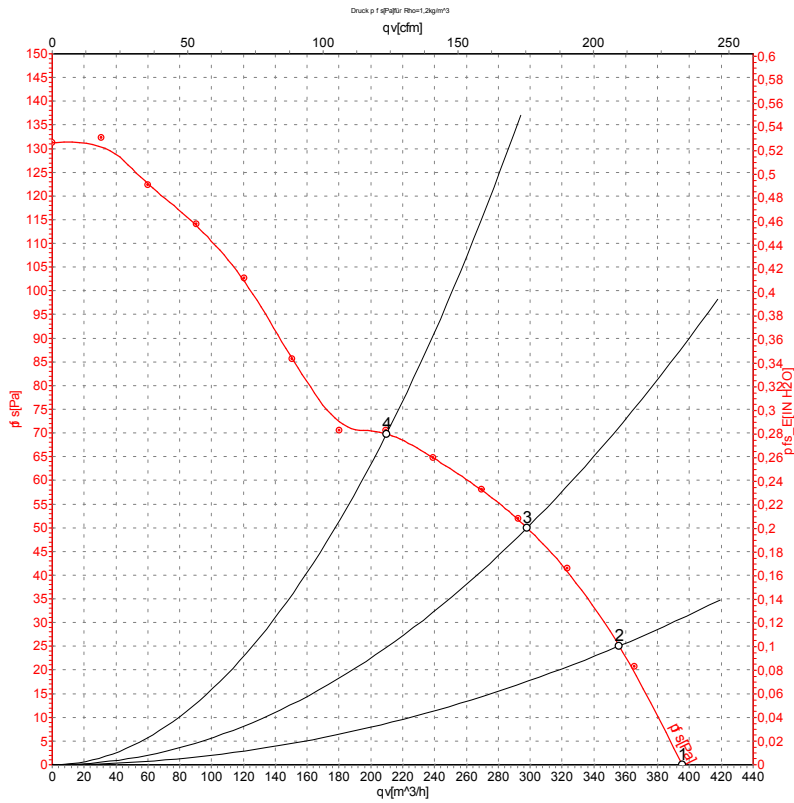

Measurement: LU-69608-1

Air performance measured according to ISO 5801 installation category A. For detailed information on the measurement setup, contact ebm-papst. Intake sound level: Sound power level according to ISO 13347 / sound pressure level measured at 1 m distance from fan axis. The values given are valid under the specified measuring conditions and may vary due to conditions of installation. For deviations from the standard configuration, the parameters have to be checked on the installed unit.

## Measured values

	U	f	n	P <sub>e</sub>	I	qv	p <sub>fs</sub>	qv	p <sub>fs</sub>
	V	Hz	min <sup>-1</sup>	W	A	m <sup>3</sup> /h	Pa	CFM	inH2O
1	400	60	3200	38	0.13	395	0	230	0.00
2	400	60	3085	43	0.14	355	25	210	0.10
3	400	60	3025	44	0.14	300	50	175	0.20
4	400	60	3035	44	0.14	210	70	125	0.28

U = Power supply · f = Frequency · n = Speed (rpm) · P<sub>e</sub> = Power consumption · I = Current draw · qv = Air flow · p<sub>fs</sub> = Pressure increase

