

ebm-papst Mulfingen GmbH & Co. KG

Bachmühle 2 · D-74673 Mulfingen

Phone +49 7938 81-0

Fax +49 7938 81-110

sales@fansco.com

www.fansco.com

Limited partnership · Headquarters Mulfingen

Amtsgericht (court of registration) Stuttgart · HRA 590344

General partner Elektrobau Mulfingen GmbH · Headquarters Mulfingen

Amtsgericht (court of registration) Stuttgart · HRB 590142

Nominal data

Type	W2S130-AA03-44			
Motor	M2S052-CA			
Phase		1~	1~	1~
Nominal voltage	VAC	230	230	230
Frequency	Hz	50	60	60
Method of obtaining data		fa	fa	fa
Valid for approval/standard		CE	CE	UL
Speed (rpm)	min ⁻¹	2800	3250	3250
Power consumption	W	45	39	39
Current draw	A	0.31	0.25	
Max. back pressure	Pa	80	120	120
Max. back pressure	inH ₂ O	0.32	0.48	0.48
Min. ambient temperature	°C	-25	-25	-25
Max. ambient temperature	°C	50	70	70
Starting current	A	0.45	0.40	

ml = Max. load · me = Max. efficiency · fa = Free air · cs = Customer specification · ce = Customer equipment
 Subject to change



Technical description

Weight	1.1 kg
Fan size	130 mm
Rotor surface	Rotor open, painted black
Blade material	Sheet steel, painted black
Fan housing material	Die-cast aluminum, painted black
Number of blades	7
Airflow direction	"V"
Direction of rotation	Counterclockwise, viewed toward rotor
Degree of protection	IP20
Insulation class	"B"
Max. permitted ambient temp. for motor (transport/storage)	+ 80 °C
Min. permitted ambient temp. for motor (transport/storage)	- 40 °C
Installation position	Any
Condensation drainage holes	None, open rotor
Mode	S1
Motor bearing	Ball bearing
Touch current according to IEC 60990 (measuring circuit Fig. 4, TN system)	< 0.75 mA
Electrical hookup	With plug
Motor protection	Thermal overload protector (TOP) internally connected
Protection class	I (if protective earth is connected by customer to the housing's connection point)
Conformity with standards	CE
Approval	UL 507; CSA C22.2 No. 113; VDE



Product drawing

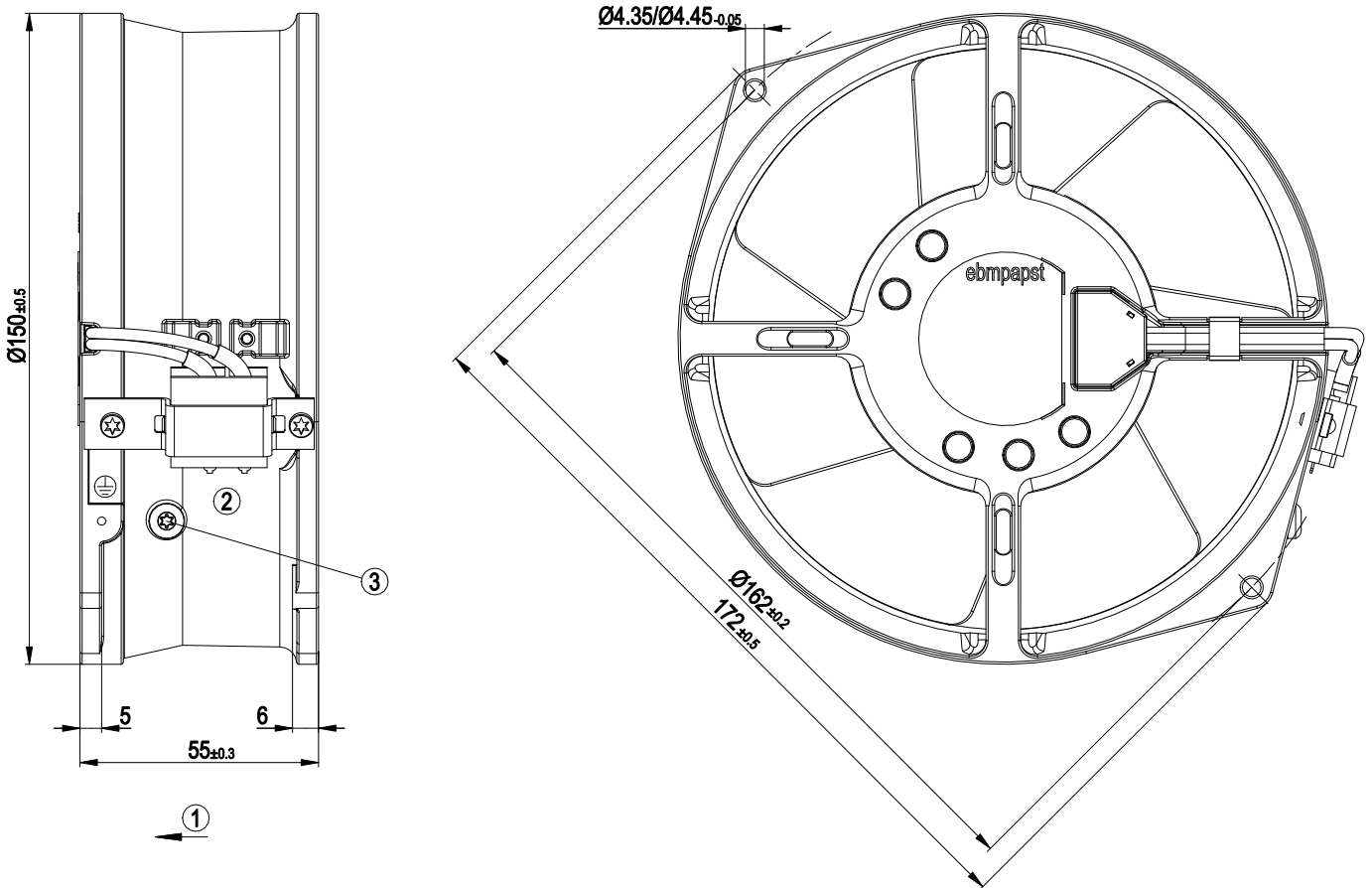

- | | |
|---|---|
| 1 | Direction of air flow "V" |
| 2 | Connector housing with 2x flat plugs 2.8 x 0.5 mm |
| 3 | M4 screw for fastening ground connector |

Connection diagram

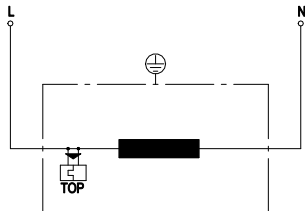

- | | |
|-----|------------------------------|
| L | = black |
| N | = black |
| TOP | = thermal overload protector |



Curves: Air performance 50 Hz

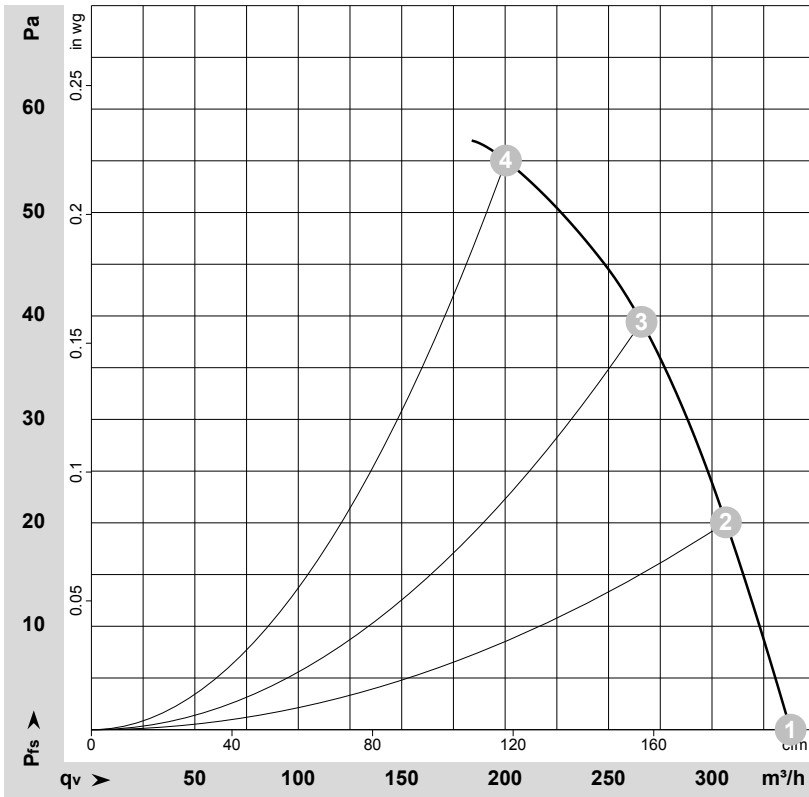

$\rho = 1.15 \text{ kg/m}^3 \pm 2 \%$

Measurement: LU-58475-1

Air performance measured according to ISO 5801 installation category A. For detailed information on the measurement setup, contact ebmpapst. Intake sound level: Sound power level according to ISO 13347 / sound pressure level measured at 1 m distance from fan axis. The values given are valid under the specified measuring conditions and may vary due to conditions of installation. For deviations from the standard configuration, the parameters have to be checked on the installed unit.

Measured values

	U	f	n	P _e	I	q _v	p _{fs}	q _v	p _{fs}
	V	Hz	min ⁻¹	W	A	m ³ /h	Pa	CFM	inH ₂ O
1	230	50	2800	45	0.31	340	0	200	0.00
2	230	50	2795	45	0.31	305	20	180	0.08
3	230	50	2780	46	0.31	265	40	155	0.16
4	230	50	2780	46	0.31	200	55	120	0.22

U = Power supply · f = Frequency · n = Speed (rpm) · P_e = Power consumption · I = Current draw · q_v = Air flow · p_{fs} = Pressure increase



Curves: Air performance 60 Hz

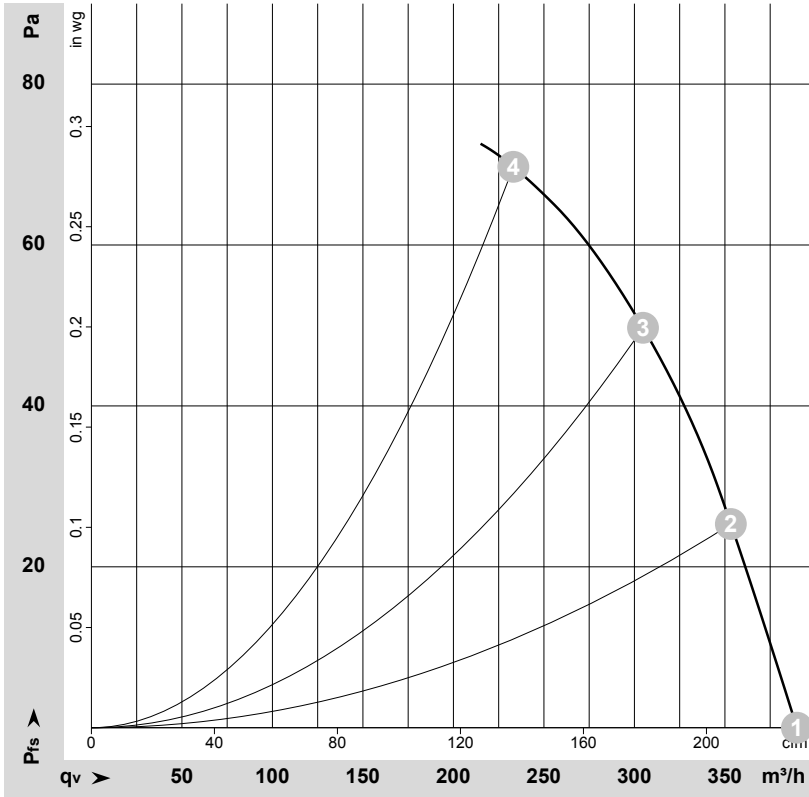

$\rho = 1.15 \text{ kg/m}^3 \pm 2 \%$

Measurement: LU-58476-1

Air performance measured according to ISO 5801 installation category A. For detailed information on the measurement setup, contact ebmpapst. Intake sound level: Sound power level according to ISO 13347 / sound pressure level measured at 1 m distance from fan axis. The values given are valid under the specified measuring conditions and may vary due to conditions of installation. For deviations from the standard configuration, the parameters have to be checked on the installed unit.

Measured values

	U	f	n	P _e	I	qv	p _{fs}	qv	p _{fs}
	V	Hz	min ⁻¹	W	A	m ³ /h	Pa	CFM	inH ₂ O
1	230	60	3250	39	0.25	390	0	230	0.00
2	230	60	3200	42	0.25	355	25	210	0.10
3	230	60	3165	43	0.26	305	50	180	0.20
4	230	60	3145	44	0.26	235	70	135	0.28

U = Power supply · f = Frequency · n = Speed (rpm) · P_e = Power consumption · I = Current draw · qv = Air flow · p_{fs} = Pressure increase

