

EC axial fan

sickle-shaped blades (S series), single-intake

ebm-papst Mulfingen GmbH & Co. KG

Bachmühle 2 · D-74673 Mulfingen

Phone +49 7938 81-0

Fax +49 7938 81-110

sales@fansco.com

www.fansco.com

Limited partnership · Headquarters Mulfingen

Amtsgericht (court of registration) Stuttgart · HRA 590344

General partner Elektrobau Mulfingen GmbH · Headquarters Mulfingen

Amtsgericht (court of registration) Stuttgart · HRB 590142

Nominal data

Type	W2G110-AP39-92	
Motor	M2G045-AI	
Nominal voltage	VDC	48
Nominal voltage range	VDC	36 .. 57
Method of obtaining data		fa
Speed (rpm)	min ⁻¹	3030
Power consumption	W	5.6
Current draw	A	0.13
Min. ambient temperature	°C	-25
Max. ambient temperature	°C	60

ml = Max. load · me = Max. efficiency · fa = Free air · cs = Customer specification · ce = Customer equipment
Subject to change



Technical description

Weight	0.5 kg
Size	110 mm
Motor size	45
Rotor surface	Painted black
Blade material	Sheet steel, painted black
Fan housing material	Die-cast aluminum, painted black
Number of blades	5
Airflow direction	A
Direction of rotation	Counterclockwise, viewed toward rotor
Degree of protection	IP22
Insulation class	"B"
Moisture (F) / Environmental (H) protection class	H0 - dry environment
Max. permitted ambient temp. for motor (transport/storage)	+80 °C
Min. permitted ambient temp. for motor (transport/storage)	-40 °C
Installation position	Any
Condensation drainage holes	None
Mode	S1
Motor bearing	Ball bearing
Technical features	- Tach output - Thermal overload protection for electronics/motor
Motor protection	Reverse polarity and locked-rotor protection
Conformity with standards	EN 60950-1

EC axial fan

sickle-shaped blades (S series), single-intake

Product drawing

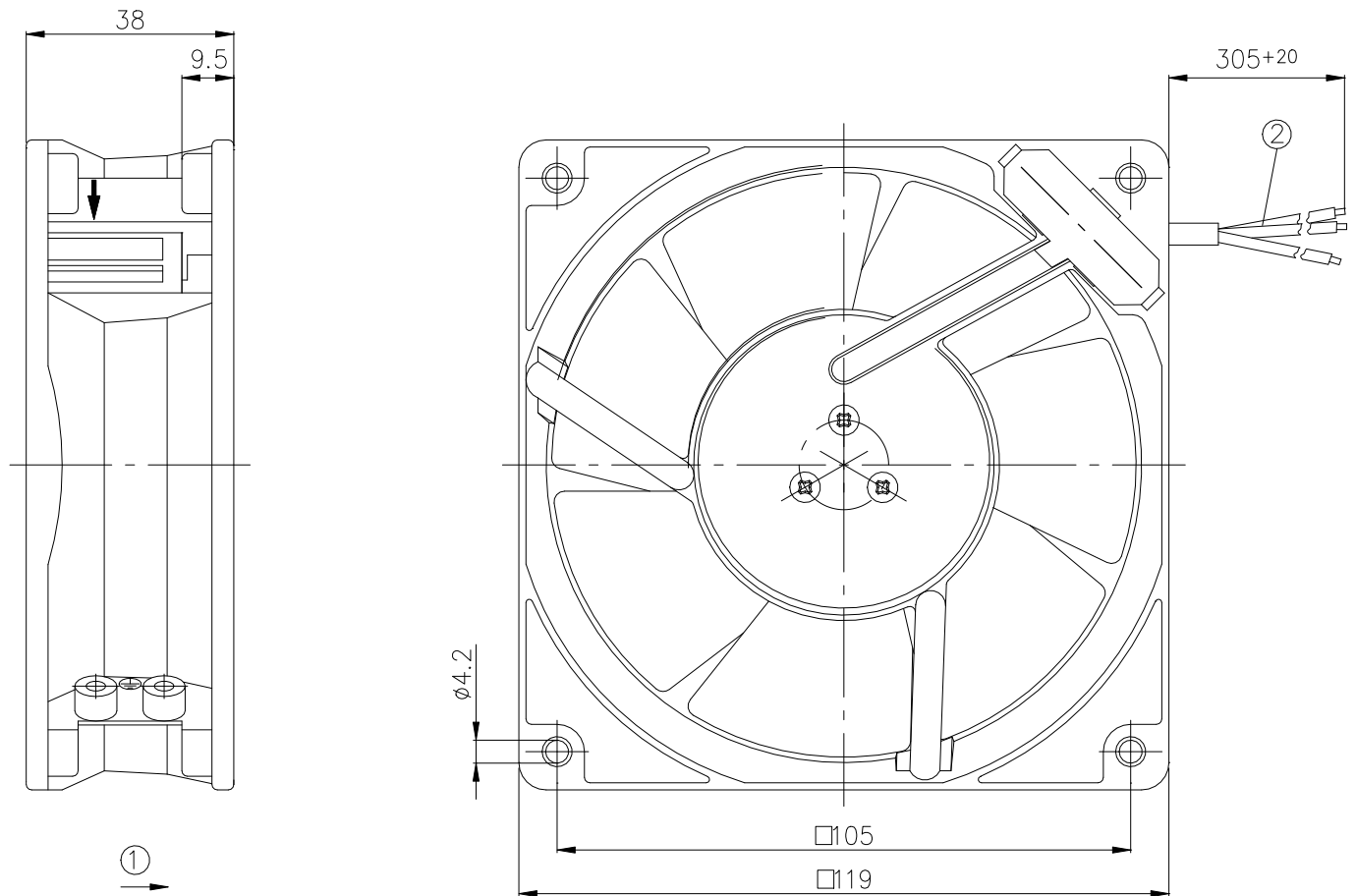

- | | |
|---|--|
| 1 | Direction of air flow "A" |
| 2 | Cable PVC AWG22, 3x tin-plated wire ends |

EC axial fan

sickle-shaped blades (S series), single-intake

Connection diagram

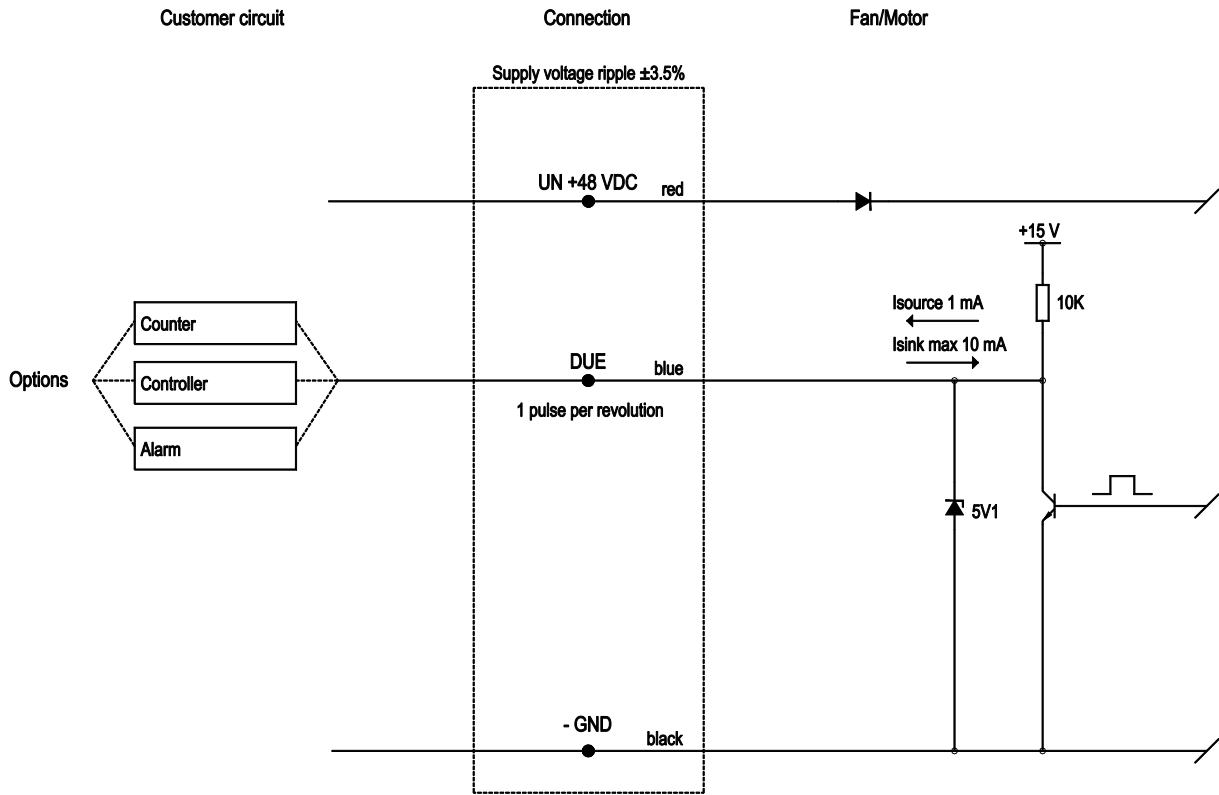

Curves: Air performance

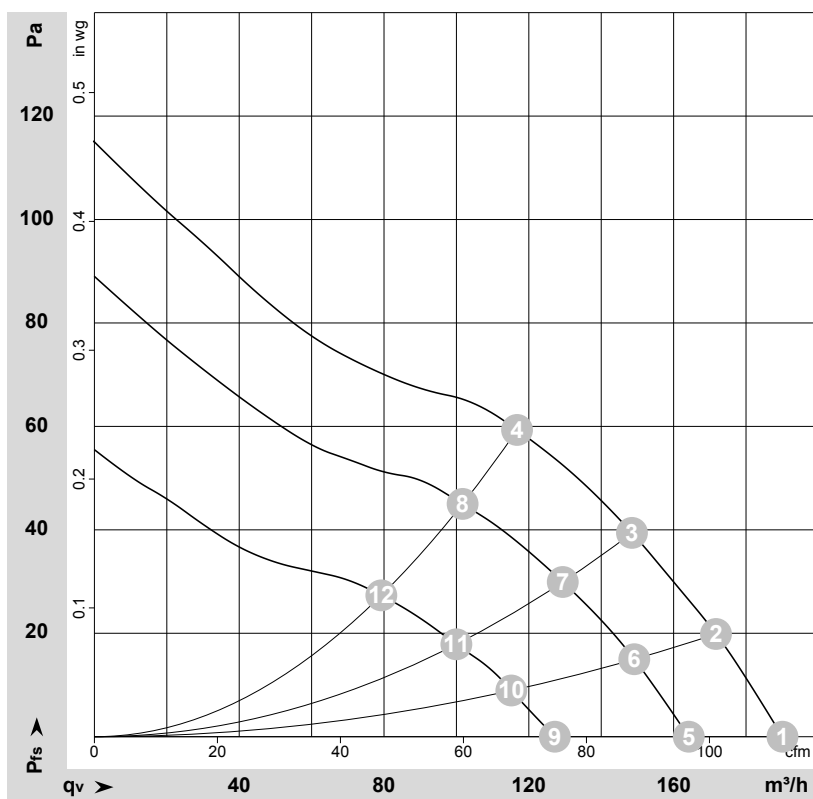

$\rho = 1.15 \text{ kg/m}^3 \pm 2 \%$

Measurement: LU-77069-1
 Measurement: LU-77068-1
 Measurement: LU-77070-1

Air performance measured according to ISO 5801 installation category A. For detailed information on the measurement setup, contact ebmpapst. Intake sound level: Sound power level according to ISO 13347 / sound pressure level measured at 1 m distance from fan axis. The values given are valid under the specified measuring conditions and may vary due to conditions of installation. For deviations from the standard configuration, the parameters have to be checked on the installed unit.

Measured values

	U	n	P _{ed}	I	q _v	p _{fs}	q _v	p _{fs}
	V	min ⁻¹	W	A	m ³ /h	Pa	cfm	in. wg
1	57	3485	8.0	0.14	190	0	110	0.00
2	57	3410	8.0	0.15	170	20	100	0.08
3	57	3330	8.0	0.15	150	40	85	0.16
4	57	3260	8.0	0.16	115	59	70	0.24
5	48	3030	5.6	0.13	165	0	95	0.00
6	48	2970	6.0	0.13	150	15	90	0.06
7	48	2905	6.0	0.13	130	30	75	0.12
8	48	2845	6.0	0.14	100	45	60	0.18
9	36	2350	3.00	0.10	125	0	75	0.00
10	36	2315	3.00	0.10	115	9	70	0.04
11	36	2275	3.00	0.11	100	18	60	0.07
12	36	2240	4.0	0.11	80	27	45	0.11

U = Voltage · n = Speed (rpm) · P_{ed} = Power consumption · I = Current draw · q_v = Air flow · p_{fs} = Pressure increase

