

**ebm-papst Mulfingen GmbH & Co. KG**

Bachmühle 2 · D-74673 Mulfingen

Phone +49 7938 81-0

Fax +49 7938 81-110

sales@fansco.com

www.fansco.com

Limited partnership · Headquarters Mulfingen

County court Stuttgart · HRA 590344

General partner Elektrobau Mulfingen GmbH · Headquarters Mulfingen

County court Stuttgart · HRB 590142

**Nominal data**

<b>Type</b>	<b>W2E200-HK38-01</b>		
<b>Motor</b>	<b>M2E068-BF</b>		
Phase		1~	1~
Nominal voltage	VAC	230	230
Frequency	Hz	50	60
Type of data definition		fa	fa
Valid for approval / standard		CE	CE
Speed (rpm)	min <sup>-1</sup>	2550	2800
Power input	W	64	80
Current draw	A	0.29	0.35
Motor capacitor	µF	1.5	1.5
Capacitor voltage	VDB	450	450
Capacitor standard		S0 (CE)	S0 (CE)
Max. back pressure	Pa	80	95
Min. ambient temperature	°C	-25	-25
Max. ambient temperature	°C	55	65
Starting current	A	0.55	0.54

ml = Max. load · me = Max. efficiency · fa = Running at free air · cs = Customer specs · cu = Customer unit  
Subject to alterations



## Technical features

<b>Mass</b>	2.1 kg
<b>Size</b>	200 mm
<b>Motor size</b>	68
<b>Surface of rotor</b>	Coated in black
<b>Material of blades</b>	Sheet steel, coated in black
<b>Material of wall ring</b>	Die-cast aluminium
<b>Number of blades</b>	7
<b>Direction of air flow</b>	V
<b>Direction of rotation</b>	Counter-clockwise, seen on rotor
<b>Type of protection</b>	IP44; Depending on installation and position
<b>Insulation class</b>	"B"
<b>Humidity (F) / environmental protection class (H)</b>	H0 - dry environment
<b>Max. permissible ambient motor temp. (transp./ storage)</b>	+ 80 °C
<b>Min. permissible ambient motor temp. (transp./storage)</b>	- 40 °C
<b>Mounting position</b>	Any
<b>Condensation drainage holes</b>	None
<b>Operation mode</b>	S1
<b>Motor bearing</b>	Ball bearing
<b>Touch current acc. IEC 60990 (measuring network Fig. 4, TN system)</b>	< 0.75 mA
<b>Electrical connection</b>	Via terminal strip, capacitor connected
<b>Motor protection</b>	Thermal overload protector (TOP) wired internally
<b>Cable exit</b>	Variable
<b>Protection class</b>	I (if protective earth is connected by customer)
<b>Motor capacitor according to EN 60252-1 in safety protection class</b>	S0
<b>Product conforming to standard</b>	EN 60335-1; CE
<b>Approval</b>	CSA C22.2 no. 113; CCC; VDE; UL 1004-3; EAC

## Product drawing

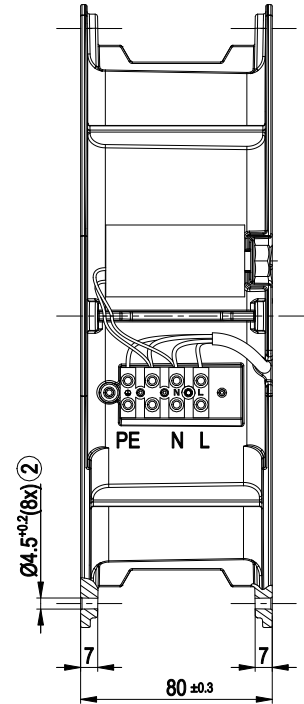
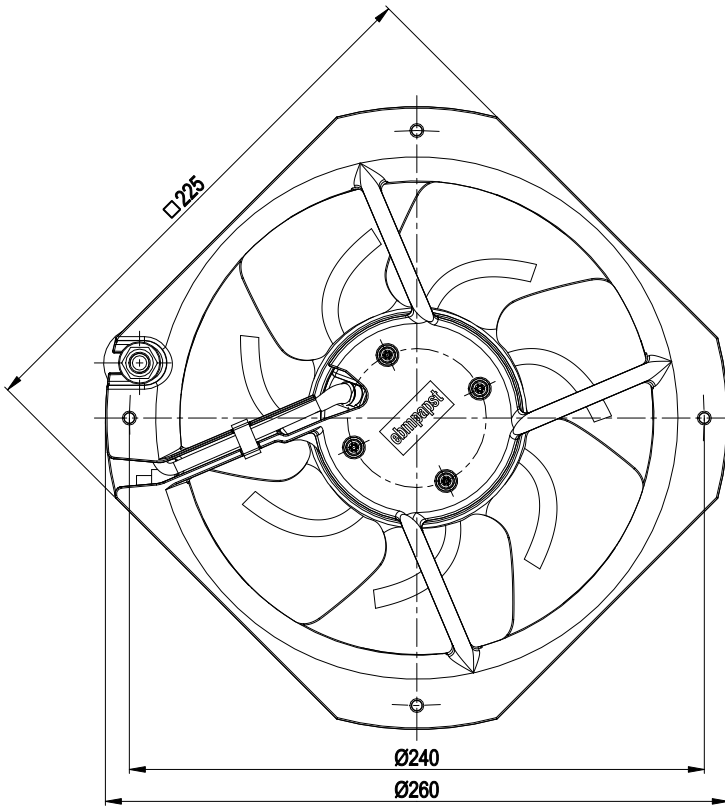

- 1 Direction of air flow "V"
- 2 For self-tapping M5 screws

## Connection screen

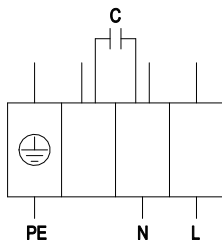

PE	green/yellow	N	black	L	blue
----	--------------	---	-------	---	------



## Charts: Air flow 50 Hz

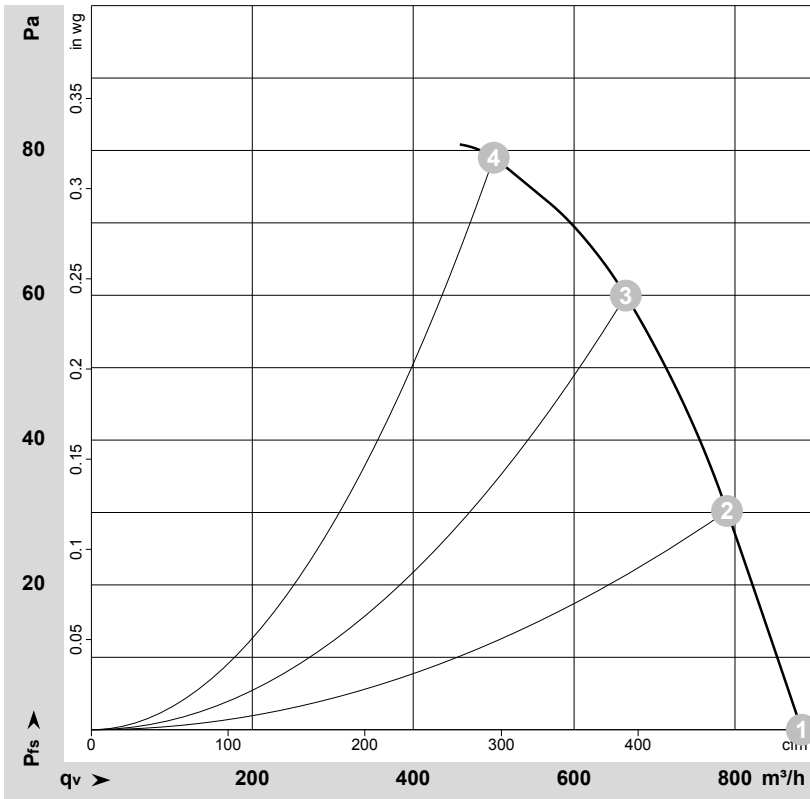

$\rho = 1.15 \text{ kg/m}^3 \pm 2 \%$

Measurement: LU-62128-1

Air performance measured as per ISO 5801 Installation category A. For detailed information on the measuring set-up, please contact ebmpapst. Suction-side noise levels: L<sub>WA</sub> measured as per ISO 13347 / L<sub>pA</sub> measured with 1m distance to fan axis. The values given are valid under the measuring conditions mentioned above and may vary according to the actual installation situation. With any deviation from the standard set-up, the specific values have to be checked and reviewed with the unit installed.

## Measured values

	U	f	n	P <sub>e</sub>	I	q <sub>v</sub>	P <sub>fs</sub>	q <sub>v</sub>	P <sub>fs</sub>
	V	Hz	min <sup>-1</sup>	W	A	m³/h	Pa	cfm	in. wg
1	230	50	2630	60	0.30	885	0	520	0.00
2	230	50	2585	64	0.31	790	30	465	0.12
3	230	50	2525	67	0.31	665	60	390	0.24
4	230	50	2480	69	0.32	500	80	295	0.32

U = Supply voltage · f = Frequency · n = Speed (rpm) · P<sub>e</sub> = Power input · I = Current draw · q<sub>v</sub> = Air flow · P<sub>fs</sub> = Pressure increase



## Charts: Air flow 60 Hz

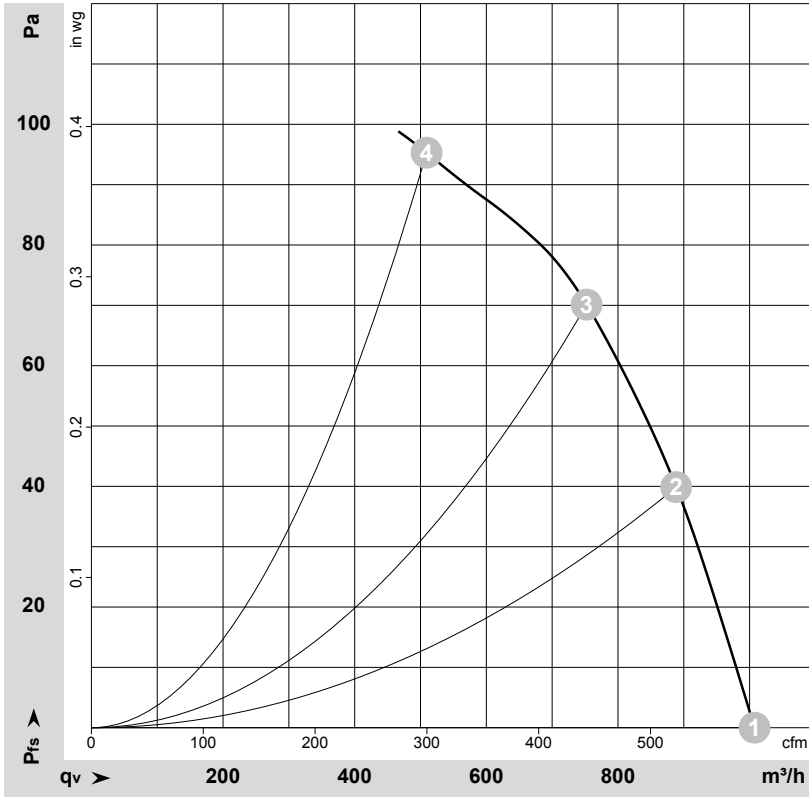

$\rho = 1.15 \text{ kg/m}^3 \pm 2 \%$

Measurement: LU-62129-1

Air performance measured as per ISO 5801 Installation category A. For detailed information on the measuring set-up, please contact ebm-papst. Suction-side noise levels: LwA measured as per ISO 13347 / LpA measured with 1m distance to fan axis. The values given are valid under the measuring conditions mentioned above and may vary according to the actual installation situation. With any deviation from the standard set-up, the specific values have to be checked and reviewed with the unit installed.

## Measured values

	U	f	n	P <sub>e</sub>	I	q <sub>v</sub>	P <sub>fs</sub>	q <sub>v</sub>	P <sub>fs</sub>
	V	Hz	min <sup>-1</sup>	W	A	m <sup>3</sup> /h	Pa	cfm	in. wg
1	230	60	3000	70	0.31	1005	0	595	0.00
2	230	60	2900	75	0.33	890	40	525	0.16
3	230	60	2800	79	0.35	750	70	445	0.28
4	230	60	2705	83	0.36	510	95	300	0.38

U = Supply voltage · f = Frequency · n = Speed (rpm) · P<sub>e</sub> = Power input · I = Current draw · q<sub>v</sub> = Air flow · P<sub>fs</sub> = Pressure increase

