

AC axial fan

sickle-shaped blades (S series)

with round full nozzle

ebm-papst Mulfingen GmbH & Co. KG

Bachmühle 2 · D-74673 Mulfingen

Phone +49 7938 81-0

Fax +49 7938 81-110

sales@fansco.com

www.fansco.com

Limited partnership · Headquarters Mulfingen

Amtsgericht (court of registration) Stuttgart · HRA 590344

General partner Elektrobau Mulfingen GmbH · Headquarters Mulfingen

Amtsgericht (court of registration) Stuttgart · HRB 590142

Nominal data

Type	W2E200-CI38-73			
Motor	M2E068-BF			
Phase		1~	1~	1~
Nominal voltage	VAC	230	230	230
Frequency	Hz	50	60	60
Method of obtaining data		fa	fa	fa
Valid for approval/standard		CE	CE	UL
Speed (rpm)	min ⁻¹	2600	2900	2900
Power consumption	W	64	78	83
Current draw	A	0.30	0.34	0.37
Capacitor	µF	1.5	1.5	1.5
Capacitor voltage	VDB	450	450	450
Capacitor standard		S0 (CE)	S0 (CE)	UL
Max. back pressure	Pa	150	150	150
Max. back pressure	inH ₂ O	0.6	0.6	0.6
Min. ambient temperature	°C	-25	-25	-25
Max. ambient temperature	°C	65	65	65
Starting current	A	0.55	0.54	

ml = Max. load · me = Max. efficiency · fa = Free air · cs = Customer specification · ce = Customer equipment
Subject to change



AC axial fan

sickle-shaped blades (S series)

with round full nozzle

Technical description

Weight	2.35 kg
Fan size	200 mm
Rotor surface	Painted black
Blade material	Sheet steel, painted black
Fan housing material	Sheet steel, pre-galvanized and coated with black plastic
Guard grille material	Steel, phosphated and coated with black plastic
Number of blades	9
Airflow direction	"A"
Direction of rotation	Counterclockwise, viewed toward rotor
Degree of protection	IP44; installation- and position-dependent as per EN 60034-5
Insulation class	"B"
Moisture (F) / Environmental (H) protection class	H0+
Max. permitted ambient temp. for motor (transport/storage)	+ 80 °C
Min. permitted ambient temp. for motor (transport/storage)	- 40 °C
Installation position	Shaft horizontal or rotor on bottom; rotor on top on request
Condensation drainage holes	On rotor side
Mode	S1
Motor bearing	Ball bearing
Touch current according to IEC 60990 (measuring circuit Fig. 4, TN system)	< 0.75 mA
Motor protection	Thermal overload protector (TOP) internally connected
With cable	Variable
Protection class	I (with customer connection of protective earth)
Conformity with standards	EN 60335-1; CE
Approval	UL 1004-3; CSA C22.2 No. 77



AC axial fan

sickle-shaped blades (S series)
with round full nozzle

Product drawing

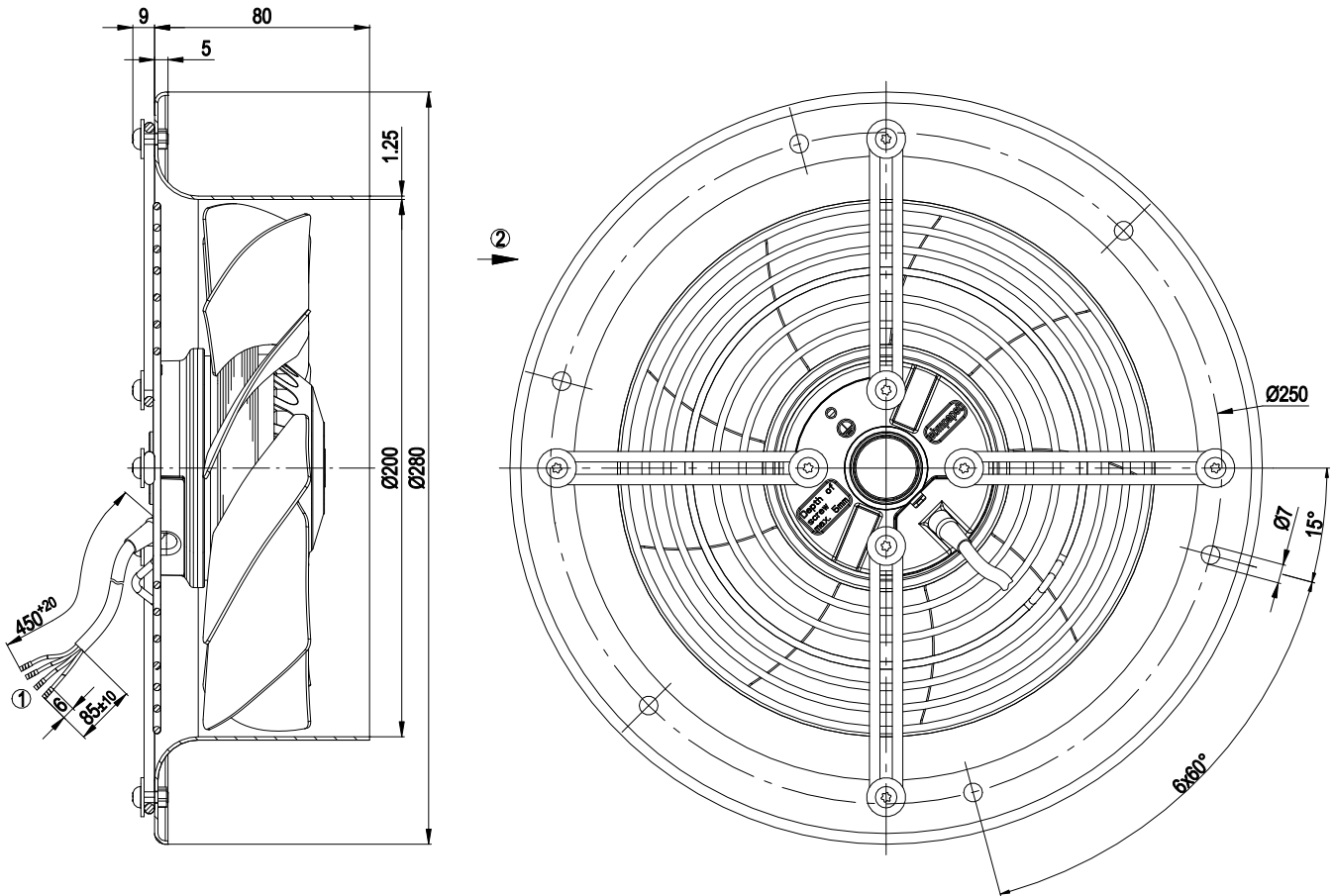

- 1 Cable PVC AWG20, 4x crimped splices
- 2 Direction of air flow "A"

Connection diagram

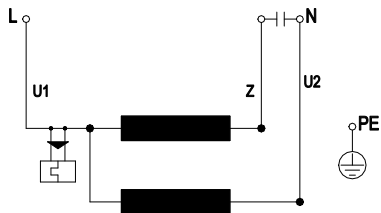

U1	blue	Z	brown	U2	black
PE	green/yellow				



AC axial fan

sickle-shaped blades (S series)
with round full nozzle

Curves: Air performance 50 Hz

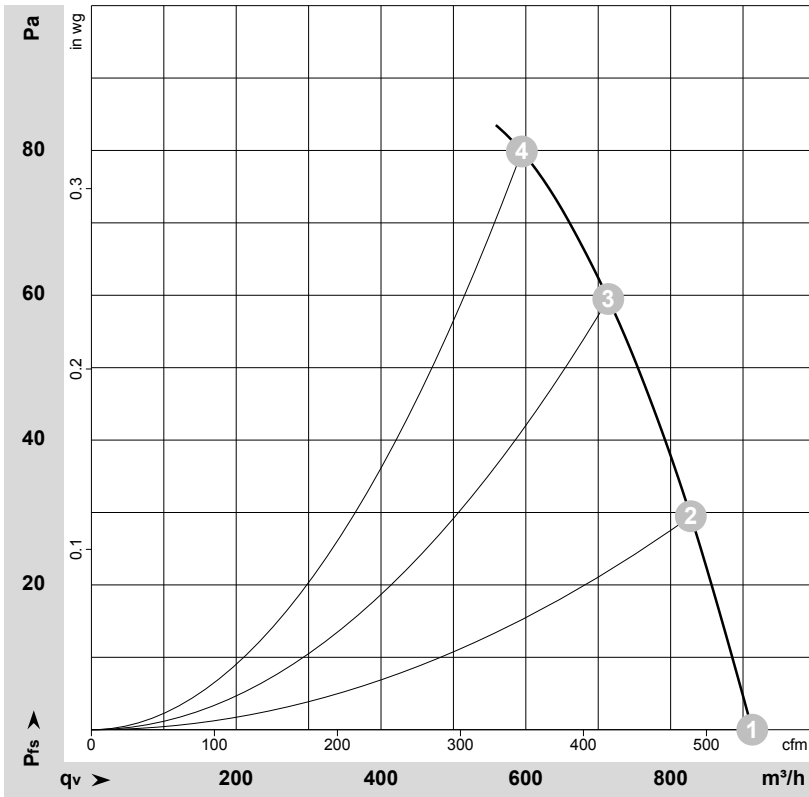

$\rho = 1.15 \text{ kg/m}^3 \pm 2 \%$

Measurement: LU-26449-1

Air performance measured according to ISO 5801 installation category A. For detailed information on the measurement setup, contact ebmpapst. Intake sound level: Sound power level according to ISO 13347 / sound pressure level measured at 1 m distance from fan axis. The values given are valid under the specified measuring conditions and may vary due to conditions of installation. For deviations from the standard configuration, the parameters have to be checked on the installed unit.

Measured values

	U	f	n	P _e	I	q _v	P _{fs}	q _v	P _{fs}
	V	Hz	min ⁻¹	W	A	m³/h	Pa	cfm	inH2O
1	230	50	2600	64	0.30	915	0	535	0.00
2	230	50	2560	66	0.30	830	30	485	0.12
3	230	50	2500	69	0.31	715	60	420	0.24
4	230	50	2465	70	0.32	595	80	350	0.32

U = Power supply · f = Frequency · n = Speed (rpm) · P_e = Power consumption · I = Current draw · q_v = Air flow · P_{fs} = Pressure increase



AC axial fan

sickle-shaped blades (S series)
with round full nozzle

Curves: Air performance 60 Hz

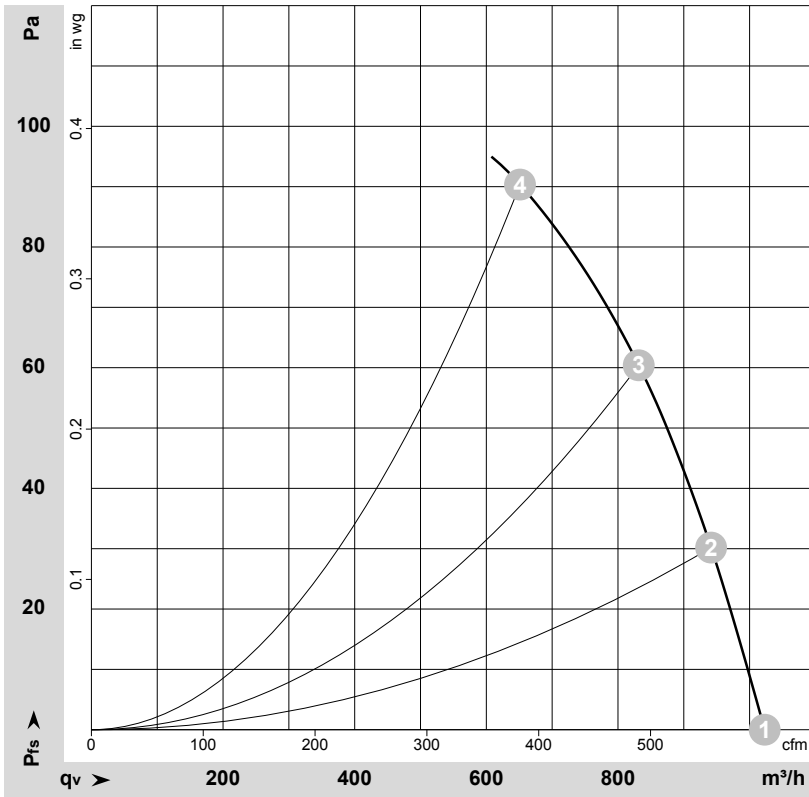

$\rho = 1.15 \text{ kg/m}^3 \pm 2 \%$

Measurement: LU-26450-1

Air performance measured according to ISO 5801 installation category A. For detailed information on the measurement setup, contact ebm-papst. Intake sound level: Sound power level according to ISO 13347 / sound pressure level measured at 1 m distance from fan axis. The values given are valid under the specified measuring conditions and may vary due to conditions of installation. For deviations from the standard configuration, the parameters have to be checked on the installed unit.

Measured values

	U	f	n	P _e	I	q _v	p _{fs}	q _v	p _{fs}
	V	Hz	min ⁻¹	W	A	m ³ /h	Pa	cfm	inH2O
1	230	60	2900	78	0.34	1025	0	600	0.00
2	230	60	2845	80	0.35	940	30	555	0.12
3	230	60	2745	84	0.36	830	60	490	0.24
4	230	60	2665	87	0.37	650	90	385	0.36

U = Power supply · f = Frequency · n = Speed (rpm) · P_e = Power consumption · I = Current draw · q_v = Air flow · p_{fs} = Pressure increase

