

AC axial fan

straight blades (A series)

with round full nozzle

ebm-papst Mulfingen GmbH & Co. KG

Bachmühle 2 · D-74673 Mulfingen

Phone +49 7938 81-0

Fax +49 7938 81-110

sales@fansco.com

www.fansco.com

Limited partnership · Headquarters Mulfingen

Amtsgericht (court of registration) Stuttgart · HRA 590344

General partner Elektrobau Mulfingen GmbH · Headquarters Mulfingen

Amtsgericht (court of registration) Stuttgart · HRB 590142

Nominal data

Type	W2E200-CF02-01		
Motor	M2E068-CA		
Phase		1~	1~
Nominal voltage	VAC	230	230
Frequency	Hz	50	60
Method of obtaining data		fa	fa
Valid for approval/standard		CE	CE
Speed (rpm)	min ⁻¹	2740	3120
Power consumption	W	50	61
Current draw	A	0.24	0.28
Capacitor	µF	1.5	1.5
Capacitor voltage	VDB	400	400
Max. back pressure	Pa	200	200
Max. back pressure	inH ₂ O	0.8	0.8
Min. ambient temperature	°C	-25	-25
Max. ambient temperature	°C	75	75
Starting current	A	0.53	0.53

ml = Max. load · me = Max. efficiency · fa = Free air · cs = Customer specification · ce = Customer equipment
Subject to change



AC axial fan

straight blades (A series)

with round full nozzle

Technical description

Weight	2.4 kg
Fan size	200 mm
Rotor surface	Painted black
Blade material	Sheet steel, painted black
Fan housing material	Sheet steel, pre-galvanized and coated with black plastic
Guard grille material	Steel, phosphated and coated with black plastic
Number of blades	5
Airflow direction	"V"
Direction of rotation	Counterclockwise, viewed toward rotor
Degree of protection	IP44; installation- and position-dependent as per EN 60034-5
Insulation class	"B"
Moisture (F) / Environmental (H) protection class	H0+
Max. permitted ambient temp. for motor (transport/storage)	+ 80 °C
Min. permitted ambient temp. for motor (transport/storage)	- 40 °C
Installation position	Any
Condensation drainage holes	On rotor side
Mode	S1
Motor bearing	Ball bearing
Touch current according to IEC 60990 (measuring circuit Fig. 4, TN system)	< 0.75 mA
Motor protection	Thermal overload protector (TOP) internally connected
With cable	Variable
Protection class	I (with customer connection of protective earth)
Conformity with standards	EN 60335-1; CE
Approval	CCC; EAC



AC axial fan

straight blades (A series)
with round full nozzle

Product drawing

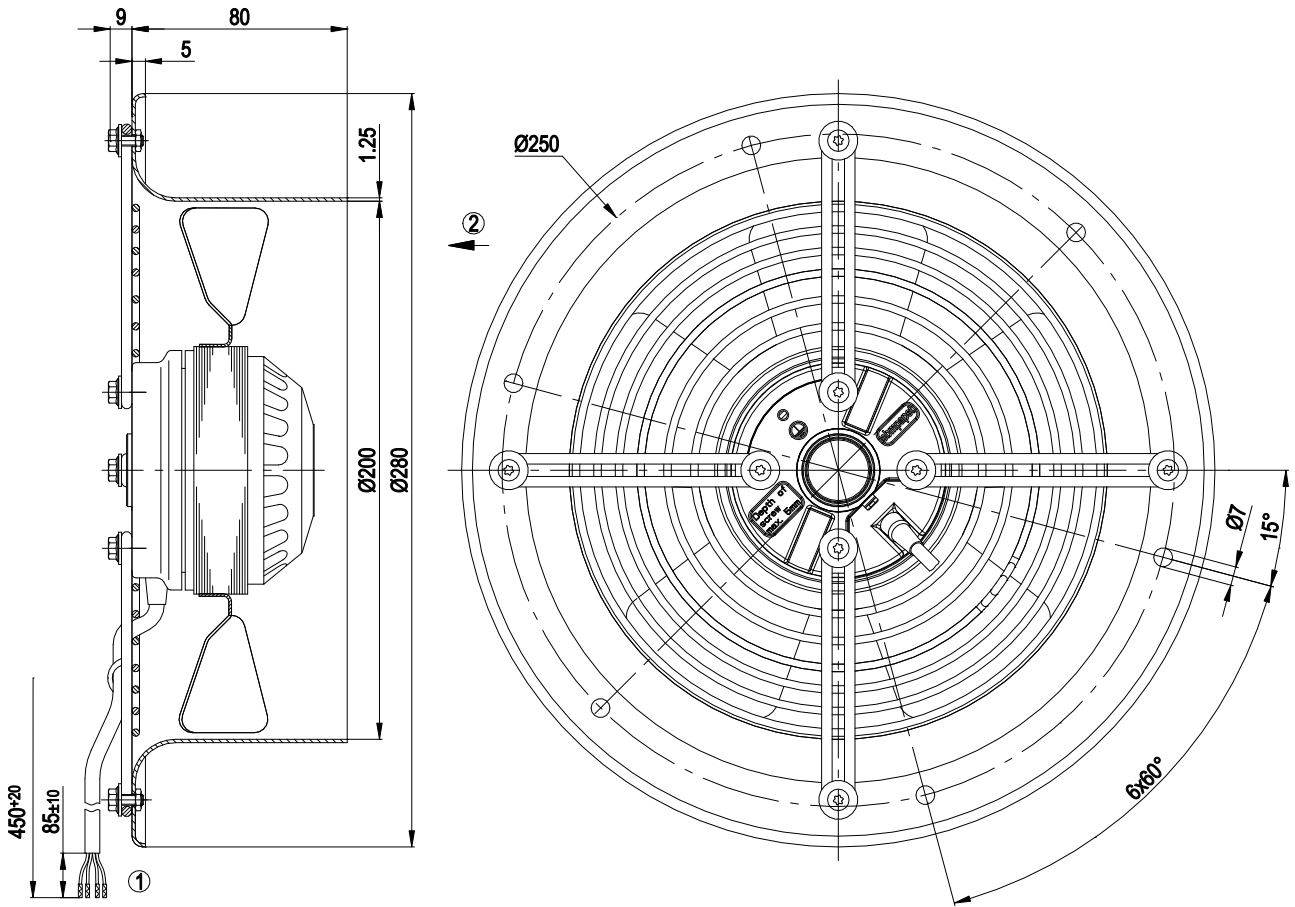

- 1 Cable PVC 4G 0.5 mm², 4x crimped splices
- 2 Direction of air flow "V"

Connection diagram

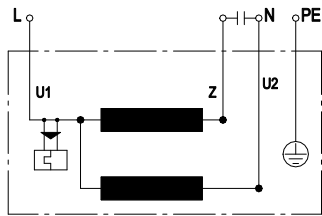

U1	blue	Z	brown	U2	black
PE	green/yellow				



AC axial fan

straight blades (A series)
with round full nozzle

Curves: Air performance 50 Hz

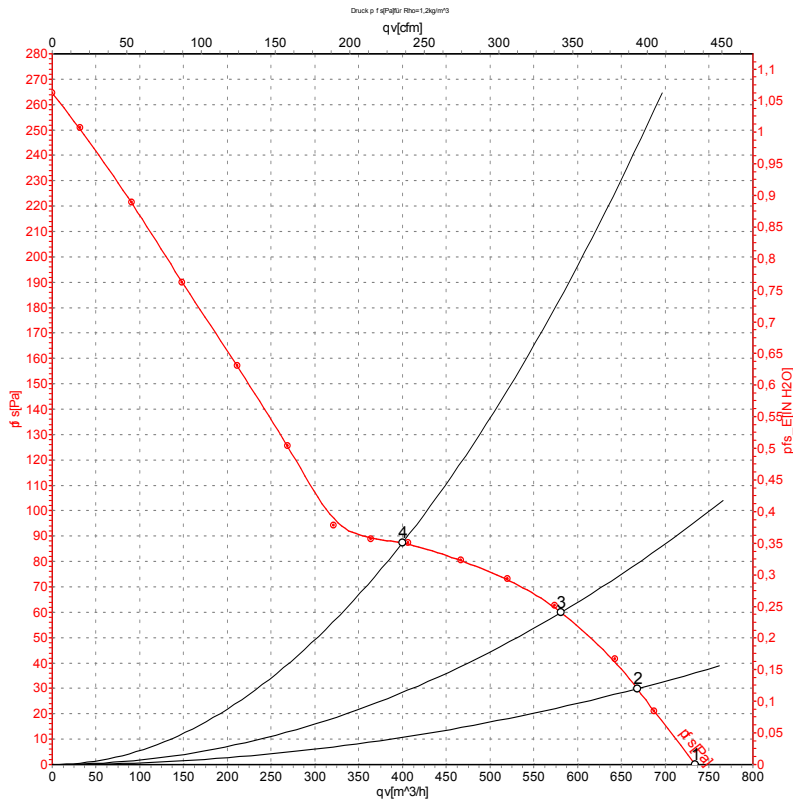

Measurement: LU-57279-1

Air performance measured according to ISO 5801 installation category A. For detailed information on the measurement setup, contact ebm-papst. Intake sound level: Sound power level according to ISO 13347 / sound pressure level measured at 1 m distance from fan axis. The values given are valid under the specified measuring conditions and may vary due to conditions of installation. For deviations from the standard configuration, the parameters have to be checked on the installed unit.

Measured values

	U	f	n	P _e	I	qv	p _{fs}	qv	p _{fs}
	V	Hz	min ⁻¹	W	A	m ³ /h	Pa	CFM	inH ₂ O
1	230	50	2740	50	0.24	740	0	435	0.00
2	230	50	2685	50	0.24	670	30	395	0.12
3	230	50	2665	52	0.24	580	60	340	0.24
4	230	50	2680	51	0.24	400	88	235	0.35

U = Power supply · f = Frequency · n = Speed (rpm) · P_e = Power consumption · I = Current draw · qv = Air flow · p_{fs} = Pressure increase



AC axial fan

straight blades (A series)
with round full nozzle

Curves: Air performance 60 Hz

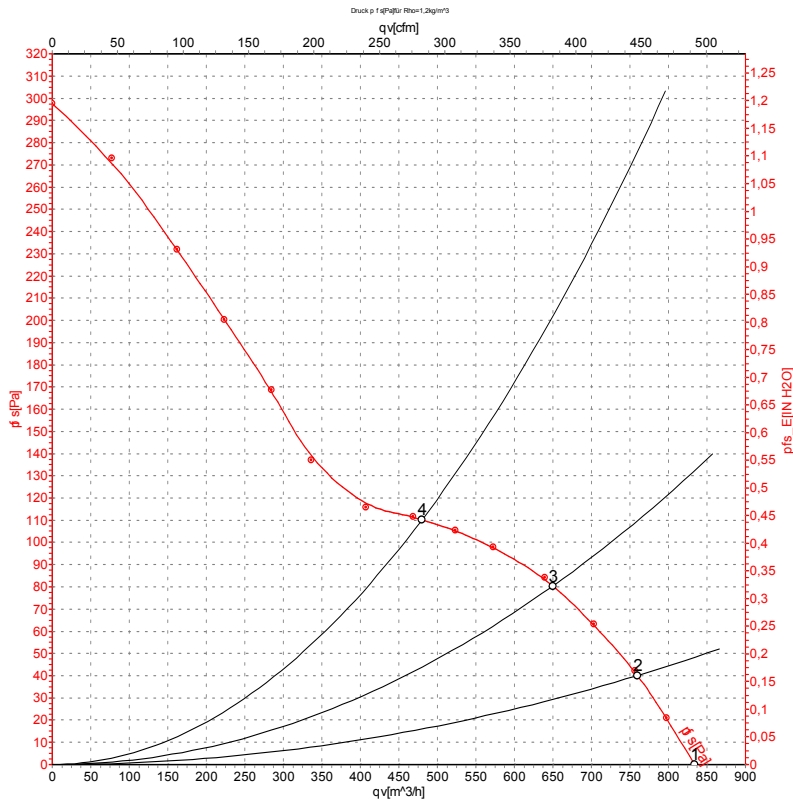

Measurement: LU-57280-1

Air performance measured according to ISO 5801 installation category A. For detailed information on the measurement setup, contact ebm-papst. Intake sound level: Sound power level according to ISO 13347 / sound pressure level measured at 1 m distance from fan axis. The values given are valid under the specified measuring conditions and may vary due to conditions of installation. For deviations from the standard configuration, the parameters have to be checked on the installed unit.

Measured values

	U	f	n	P _e	I	qv	p _{fs}	qv	p _{fs}
	V	Hz	min ⁻¹	W	A	m ³ /h	Pa	CFM	inH ₂ O
1	230	60	3120	61	0.28	830	0	490	0.00
2	230	60	3045	65	0.28	760	40	445	0.16
3	230	60	3005	68	0.29	650	80	385	0.32
4	230	60	3035	66	0.29	480	110	285	0.44

U = Power supply · f = Frequency · n = Speed (rpm) · P_e = Power consumption · I = Current draw · qv = Air flow · p_{fs} = Pressure increase

