

# AC axial fan - HyBlade

sickle-shaped blades (S series)

with guard grille for short nozzle

## ebm-papst Mulfingen GmbH & Co. KG

Bachmühle 2 · D-74673 Mulfingen

Phone +49 7938 81-0

Fax +49 7938 81-110

sales@fansco.com

www.fansco.com

Limited partnership · Headquarters Mulfingen

Amtsgericht (court of registration) Stuttgart · HRA 590344

General partner Elektrobau Mulfingen GmbH · Headquarters Mulfingen

Amtsgericht (court of registration) Stuttgart · HRB 590142

## Nominal data

Type	S6E630-AN01-01	
Motor	M6E110-GF	
Phase		1~
Nominal voltage	VAC	230
Frequency	Hz	50
Method of obtaining data		ml
Valid for approval/standard		CE
Speed (rpm)	min <sup>-1</sup>	860
Power consumption	W	600
Current draw	A	2.62
Capacitor	µF	14
Capacitor voltage	VDB	400
Capacitor standard		S0 (CE)
Max. back pressure	Pa	100
Max. back pressure	in. wg	0.4
Min. ambient temperature	°C	-40
Max. ambient temperature	°C	55
Starting current	A	4.8

ml = Max. load · me = Max. efficiency · fa = Free air · cs = Customer specification · ce = Customer equipment  
Subject to change

## Data according to Commission Regulation (EU) 327/2011 (EN 17166)

		Actual	Req. 2015			
01 Overall efficiency $\eta_{es}$	%	32.7	32.1	09 Power consumption $P_e$	kW	0.55
02 Measurement category		A		09 Air flow $q_v$	m <sup>3</sup> /h	7130
03 Efficiency category		Static		09 Pressure increase $p_{fs}$	Pa	92
04 Efficiency grade N		40.6	40	10 Speed (rpm) n	min <sup>-1</sup>	870
05 Variable speed drive		No		11 Specific ratio*		1.00

Data obtained at optimum efficiency level.

\* Specific ratio =  $1 + p_g / 100\,000\text{ Pa}$

LU-199801

The efficiency values displayed for achieving conformity with the Ecodesign Regulation EU 327/2011 has been reached with defined air duct components (e.g. inlet rings). The dimensions must be requested from ebm-papst. If other air conduction geometries are used on the installation side, the ebm-papst evaluation loses its validity/the conformity must be confirmed again.

The product does not fall within the scope of Regulation (EU) 2019/1781 due to the exception specified in Article 2 (2a) (motors completely integrated into a product).



# AC axial fan - HyBlade

sickle-shaped blades (S series)

with guard grille for short nozzle

## Technical description

<b>Weight</b>	13.9 kg
<b>Size</b>	630 mm
<b>Motor size</b>	110
<b>Rotor surface</b>	Painted black
<b>Terminal box material</b>	PP plastic
<b>Blade material</b>	Press-fitted sheet steel blank, sprayed with PP plastic
<b>Guard grille material</b>	Steel, coated with black plastic (RAL 9005)
<b>Number of blades</b>	5
<b>Airflow direction</b>	V
<b>Direction of rotation</b>	Counterclockwise, viewed toward rotor
<b>Degree of protection</b>	IP54
<b>Insulation class</b>	"F"
<b>Moisture (F) / Environmental (H) protection class</b>	H2
<b>Max. permitted ambient temp. for motor (transport/storage)</b>	+ 80 °C
<b>Min. permitted ambient temp. for motor (transport/storage)</b>	- 40 °C
<b>Installation position</b>	Shaft horizontal or rotor on bottom; rotor on top on request
<b>Condensation drainage holes</b>	On rotor side
<b>Mode</b>	S1
<b>Motor bearing</b>	Ball bearing
<b>Touch current according to IEC 60990 (measuring circuit Fig. 4, TN system)</b>	<= 3.5 mA
<b>Electrical hookup</b>	Terminal box; Via terminal box, capacitor integrated and connected
<b>Motor protection</b>	Thermal overload protector (TOP) with basic insulation
<b>With cable</b>	Axial
<b>Protection class</b>	I (with customer connection of protective earth)
<b>Motor capacitor according to EN 60252-1 in safety protection class</b>	S0
<b>Conformity with standards</b>	EN 61800-5-1; UKCA; CE
<b>Approval</b>	EAC; CCC; VDE



# AC axial fan - HyBlade

sickle-shaped blades (S series)  
with guard grille for short nozzle

## Product drawing

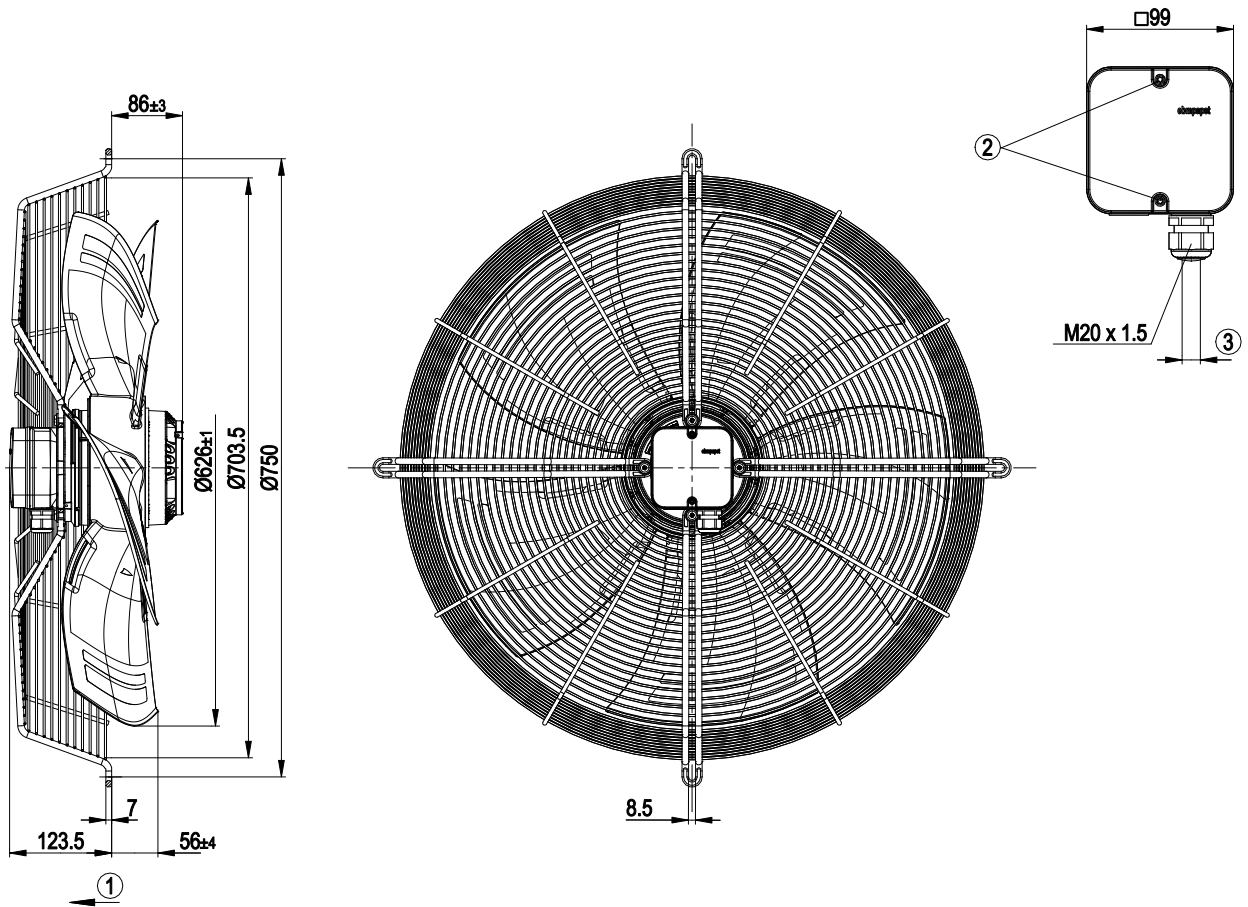

1	Direction of air flow "V"
2	Tightening torque 1.5 ± 0.2 Nm
3	Cable diameter min. 6 mm, max. 12 mm; tightening torque 2 ± 0.3 Nm



# AC axial fan - HyBlade

sickle-shaped blades (S series)  
with guard grille for short nozzle

## Connection diagram

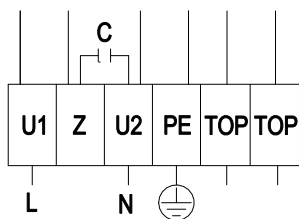

L	= U1 = blue	Z	brown	N	= U2 = black
PE	green/yellow	TOP	gray		



# AC axial fan - HyBlade

sickle-shaped blades (S series)  
with guard grille for short nozzle

## Curves: Air performance 50 Hz

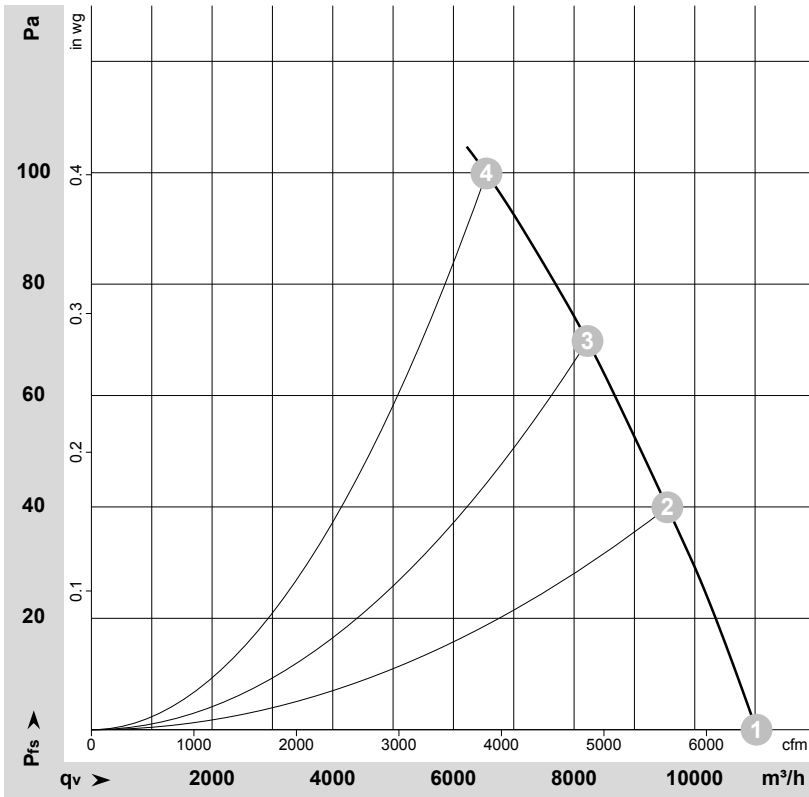

$\rho = 1.177 \text{ kg/m}^3 \pm 2 \%$

Measurement: LU-105789-1

Air performance measured according to ISO 5801 installation category A. For detailed information on the measurement setup, contact ebmpapst. Intake sound level: Sound power level according to ISO 13347 / sound pressure level measured at 1 m distance from fan axis. The values given are valid under the specified measuring conditions and may vary due to conditions of installation. For deviations from the standard configuration, the parameters have to be checked on the installed unit.

## Measured values

	U	f	n	P <sub>e</sub>	I	LpA <sub>in</sub>	LwA <sub>in</sub>	LwA <sub>out</sub>	q <sub>v</sub>	P <sub>fs</sub>	q <sub>v</sub>	P <sub>fs</sub>
	V	Hz	min <sup>-1</sup>	W	A	dB(A)	dB(A)	dB(A)	m <sup>3</sup> /h	Pa	cfm	in. wg
1	230	50	925	467	2.04	64	70	70	11025	0	6490	0.00
2	230	50	905	522	2.27	61	67	67	9545	40	5620	0.16
3	230	50	885	559	2.44	60	66	65	8220	70	4840	0.28
4	230	50	860	600	2.62	61	68	67	6550	100	3855	0.40

U = Voltage · f = Frequency · n = Speed (rpm) · P<sub>e</sub> = Power consumption · I = Current draw · LpA<sub>in</sub> = Sound pressure level intake side · LwA<sub>in</sub> = Sound power level intake side  
LwA<sub>out</sub> = Sound power level outlet side · q<sub>v</sub> = Air flow · P<sub>fs</sub> = Pressure increase

