

S4E360-EC20-51

AC axial fan

blades with special design (K series)

with guard grille for full nozzle



ebm-papst Mulfingen GmbH & Co. KG

Bachmühle 2 · D-74673 Mulfingen

Phone +49 7938 81-0

Fax +49 7938 81-110

sales@fansco.com

www.fansco.com

Limited partnership · Headquarters Mulfingen
County court Stuttgart · HRA 590344

General partner Elektrobau Mulfingen GmbH · Headquarters Mulfingen
County court Stuttgart · HRB 590142

Nominal data

Type	S4E360-EC20-51		
Motor	M4E068-DF		
Phase		1~	1~
Nominal voltage	VAC	230	230
Frequency	Hz	50	60
Type of data definition		fa	fa
Valid for approval / standard		CE	CE
Speed	min ⁻¹	1320	1430
Power input	W	115	145
Current draw	A	0.54	0.64
Motor capacitor	µF	3	3
Capacitor voltage	VDB	400	400
Capacitor standard		P0 (CE)	P0 (CE)
Max. back pressure	Pa	55	40
Min. ambient temperature	°C	-25	-25
Max. ambient temperature	°C	40	40
Starting current	A	1.1	1.06

ml = Max. load · me = Max. efficiency · fa = Running at free air · cs = Customer specs · cu = Customer unit
Subject to alterations



AC axial fan

blades with special design (K series)

with guard grille for full nozzle

Technical features

Mass	3 kg
Size	360 mm
Surface of rotor	Coated in black
Material of blades	PP plastic
Number of blades	4
Direction of air flow	"V"
Direction of rotation	Counter-clockwise, seen on rotor
Type of protection	IP 44; Depending on installation and position as per EN 60034-1
Insulation class	"B"
Humidity class	F1-2
Max. permissible ambient motor temp. (transp./ storage)	+ 80 °C
Min. permissible ambient motor temp. (transp./storage)	- 40 °C
Mounting position	Shaft horizontal or rotor on bottom; rotor on top on request
Condensate discharge holes	Rotor-side
Operation mode	S1
Motor bearing	Ball bearing
Touch current acc. IEC 60990 (measuring network Fig. 4, TN system)	< 0.75 mA
Motor protection	Thermal overload protector (TOP) wired internally
Cable exit	Axial
Protection class	I (if protective earth is connected by customer at the connection point of the housing)
Product conforming to standard	EN 60335-1; CE
Approval	UL 2111



S4E360-EC20-51

AC axial fan

blades with special design (K series)
with guard grille for full nozzle

Product drawing

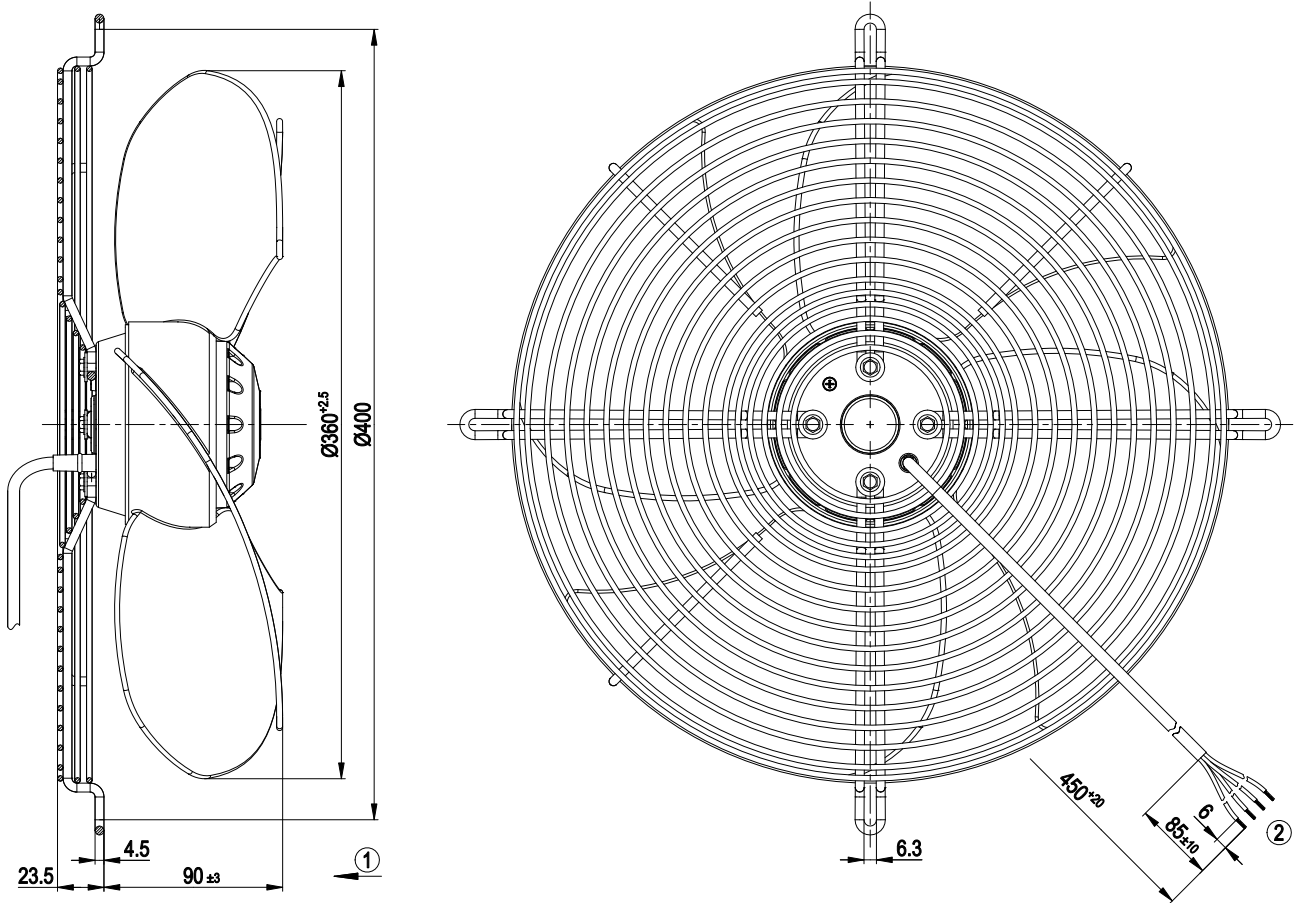

- | | |
|---|--|
| 1 | Direction of air flow "V" |
| 2 | Connection line PVC 4G AWG20, 4x lead tips crimped |

Connection screen

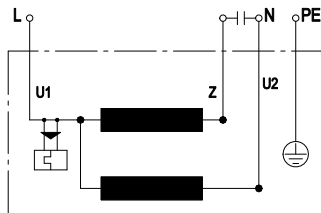

U1	blue	Z	brown	U2	black
PE	green/yellow				



AC axial fan

blades with special design (K series)

with guard grille for full nozzle

Charts: Air flow 50 Hz

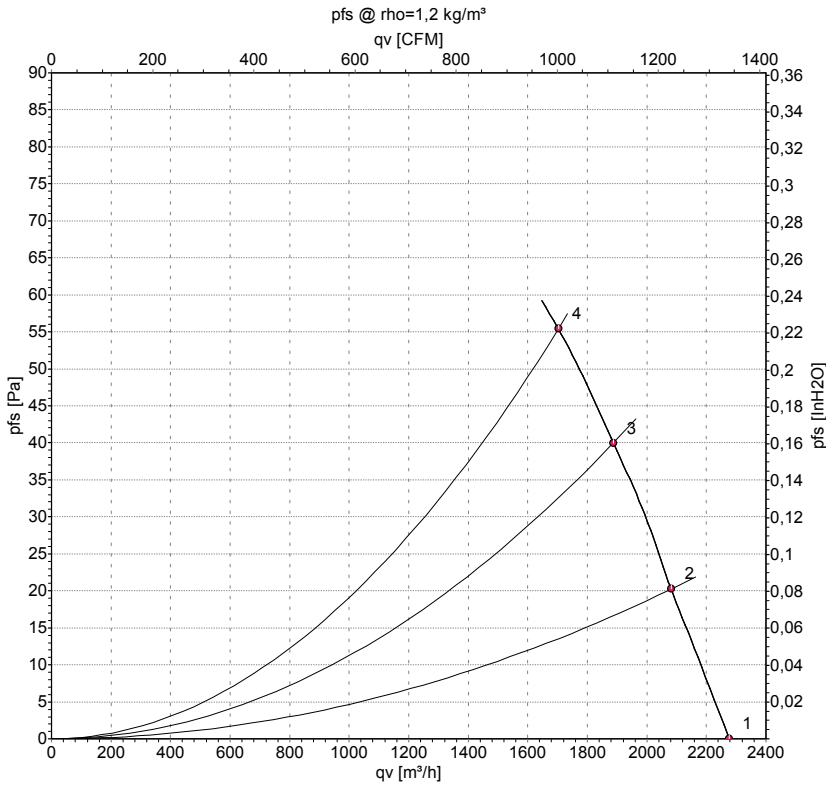

Measurement: LU-41798

Air performance measured as per ISO 5801 Installation category A. For detailed information on the measuring set-up, please contact ebm-papst. Suction-side noise levels: LwA measured as per ISO 13347 / LpA measured with 1m distance to fan axis. The values given are valid under the measuring conditions mentioned above and may vary according to the actual installation situation. With any deviation from the standard set-up, the specific values have to be checked and reviewed with the unit installed.

Measured values

	U	f	n	P _e	I	qv	p _{fs}
	V	Hz	min ⁻¹	W	A	m³/h	Pa
1	230	50	1320	115	0.54	2275	0
2	230	50	1310	116	0.56	2080	20
3	230	50	1300	119	0.57	1885	40
4	230	50	1295	121	0.58	1705	55

U = Supply voltage · f = Frequency · n = Speed · P_e = Power input · I = Current draw · qv = Air flow · p_{fs} = Pressure increase



AC axial fan

blades with special design (K series)

with guard grille for full nozzle

Charts: Air flow 60 Hz

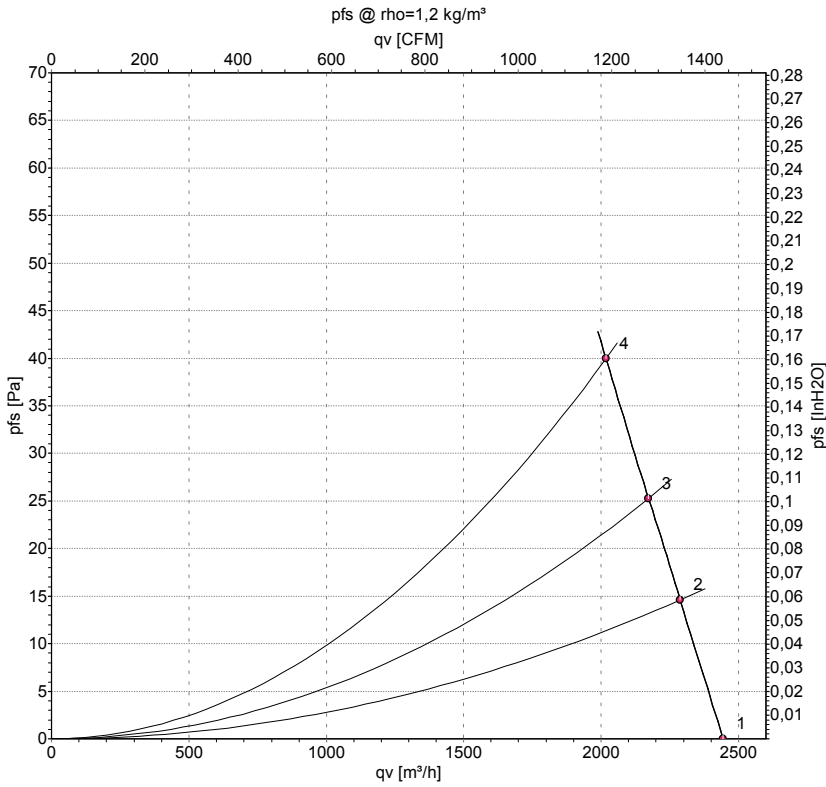

Measurement: LU-41799

Air performance measured as per ISO 5801 Installation category A. For detailed information on the measuring set-up, please contact ebm-papst. Suction-side noise levels: LwA measured as per ISO 13347 / LpA measured with 1m distance to fan axis. The values given are valid under the measuring conditions mentioned above and may vary according to the actual installation situation. With any deviation from the standard set-up, the specific values have to be checked and reviewed with the unit installed.

Measured values

	U	f	n	P _e	I	qv	p _{fs}
	V	Hz	min ⁻¹	W	A	m³/h	Pa
1	230	60	1430	145	0.64	2445	0
2	230	60	1415	146	0.64	2290	15
3	230	60	1400	149	0.66	2175	25
4	230	60	1380	152	0.67	2020	40

U = Supply voltage · f = Frequency · n = Speed · P_e = Power input · I = Current draw · qv = Air flow · p_{fs} = Pressure increase

