

S4D400-AP12-77

# AC axial fan

sickled blades (S series), single inlet  
with guard grille for short nozzle



## ebm-papst Mulfingen GmbH & Co. KG

Bachmühle 2 · D-74673 Mulfingen

Phone +49 7938 81-0

Fax +49 7938 81-110

sales@fansco.com

www.fansco.com

Limited partnership · Headquarters Mulfingen  
County court Stuttgart · HRA 590344

General partner Elektrobau Mulfingen GmbH · Headquarters Mulfingen  
County court Stuttgart · HRB 590142



## Nominal data

Type	S4D400-AP12-77		
Motor	M4D074-EI		
Phase		3~	3~
Nominal voltage	VAC	400	460
Connection		Y	Y
Frequency	Hz	50	60
Type of data definition		fa	fa
Valid for approval / standard		CE	CE
Speed	min <sup>-1</sup>	1450	1695
Power input	W	135	235
Current draw	A	0.44	0.5
Max. back pressure	Pa	150	130
Min. ambient temperature	°C	-25	-25
Max. ambient temperature	°C	60	55
Starting current	A	1.7	

ml = Max. load · me = Max. efficiency · fa = Running at free air · cs = Customer specs · cu = Customer unit  
Subject to alterations

## Data according to ErP directive

Installation category	A
Efficiency category	Static
Variable speed drive	No
Specific ratio*	1.00

\* Specific ratio =  $1 + p_{fs} / 100\,000\text{ Pa}$

	Actual	Request 2013	Request 2015
Overall efficiency $\eta_{es}$	32.7	25.1	29.1
Efficiency grade N	43.6	36	40
Power input $P_e$	kW	0.19	
Air flow $q_v$	m <sup>3</sup> /h	2595	
Pressure increase $p_{fs}$	Pa	91	
Speed n	min <sup>-1</sup>	1415	

Data established at point of optimum efficiency



# AC axial fan

sickled blades (S series), single inlet  
with guard grille for short nozzle

## Technical features

<b>Mass</b>	5.1 kg
<b>Size</b>	400 mm
<b>Surface of rotor</b>	Coated in black
<b>Material of blades</b>	Sheet steel, coated in black
<b>Material of guard grille</b>	Steel, coated in black plastic (RAL9005)
<b>Number of blades</b>	5
<b>Direction of air flow</b>	"V"
<b>Direction of rotation</b>	Counter-clockwise, seen on rotor
<b>Type of protection</b>	IP 44
<b>Insulation class</b>	"F"
<b>Humidity class</b>	F2-2
<b>Max. permissible ambient motor temp. (transp./ storage)</b>	+ 80 °C
<b>Min. permissible ambient motor temp. (transp./storage)</b>	- 40 °C
<b>Mounting position</b>	Shaft horizontal or rotor on bottom; rotor on top on request
<b>Condensate discharge holes</b>	Rotor-side
<b>Operation mode</b>	S1
<b>Motor bearing</b>	Ball bearing
<b>Touch current acc. IEC 60990 (measuring network Fig. 4, TN system)</b>	< 0.75 mA
<b>Cable exit</b>	Variable
<b>Protection class</b>	I (if protective earth is connected by customer)
<b>Approval</b>	UL 1004-1; CSA C22.2 Nr.100



# AC axial fan

sickled blades (S series), single inlet  
with guard grille for short nozzle

## Product drawing

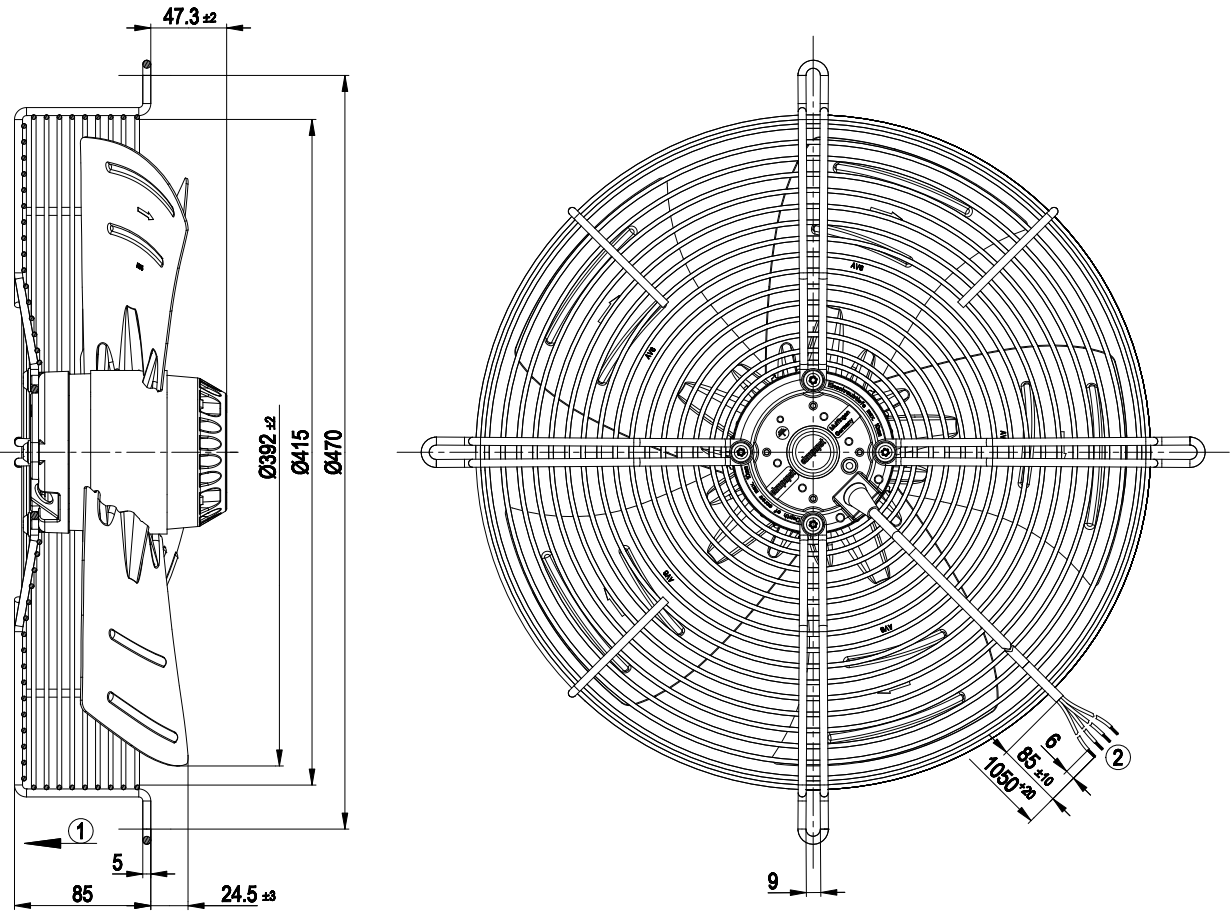

- 1 Direction of air flow "V"
- 2 Connection line PFA 4G AWG20, 4x brass lead tips crimped



# AC axial fan

sickled blades (S series), single inlet  
with guard grille for short nozzle

## Connection screen

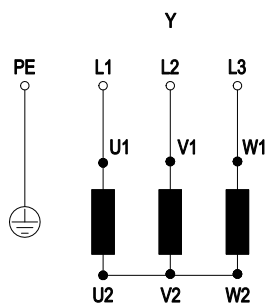

Changing the direction of rotation by reversing the two phases

PE	green/yellow	L1	black	L2	blue
L3	brown	Y	Star connection		

# AC axial fan

sickled blades (S series), single inlet  
with guard grille for short nozzle

## Charts: Air flow 50 Hz

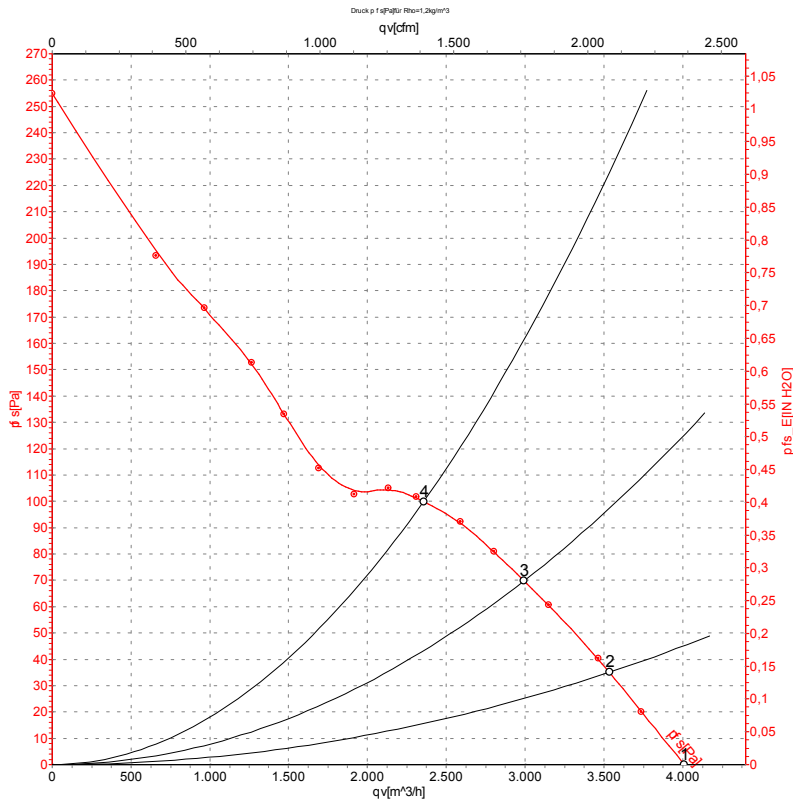

Measurement: LU-27622

Air performance measured as per ISO 5801 Installation category A. For detailed information on the measuring set-up, please contact ebm-papst. Suction-side noise levels: LwA measured as per ISO 13347 / LpA measured with 1m distance to fan axis. The values given are valid under the measuring conditions mentioned above and may vary according to the actual installation situation. With any deviation from the standard set-up, the specific values have to be checked and reviewed with the unit installed.

## Measured values

	Conn.	U	f	n	P <sub>e</sub>	I	LpA <sub>in</sub>	LwA <sub>in</sub>	qv	p <sub>fs</sub>
		V	Hz	min <sup>-1</sup>	W	A	dB(A)	dB(A)	m <sup>3</sup> /h	Pa
1	Y	400	50	1450	135	0.44	65	74	4000	0
2	Y	400	50	1435	161	0.47	65	73	3535	35
3	Y	400	50	1420	182	0.49	65	72	2995	70
4	Y	400	50	1410	203	0.50	67	74	2355	100

Conn. = Connection · U = Supply voltage · f = Frequency · n = Speed · P<sub>e</sub> = Power input · I = Current draw · LpA<sub>in</sub> = Sound pressure level inlet side · LwA<sub>in</sub> = Sound power level inlet side  
qv = Air flow · p<sub>fs</sub> = Pressure increase



# AC axial fan

sickled blades (S series), single inlet  
with guard grille for short nozzle

## Charts: Air flow 60 Hz

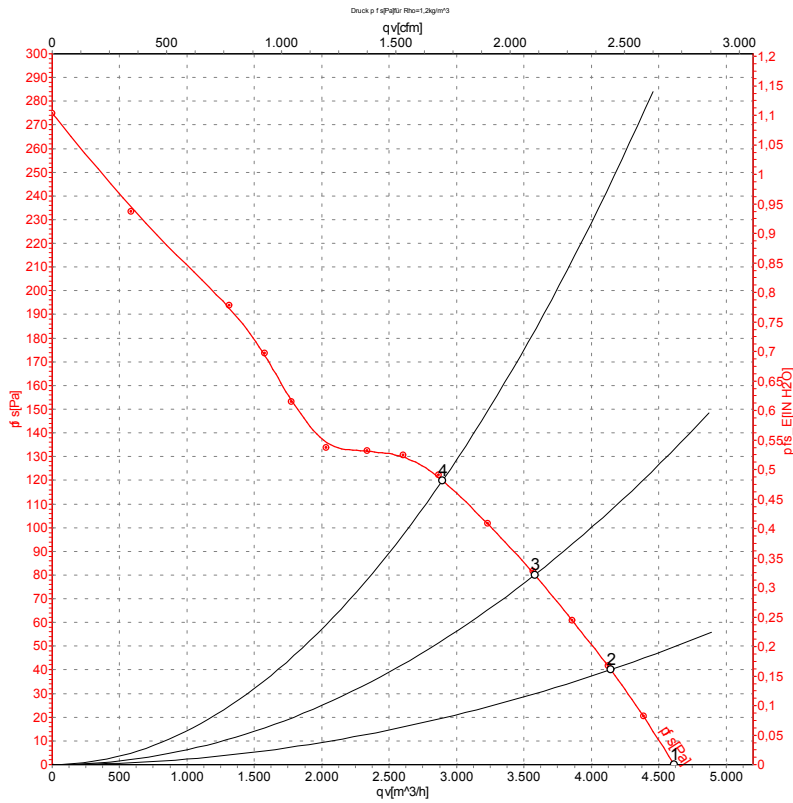

Measurement: LU-27623

Air performance measured as per ISO 5801 Installation category A. For detailed information on the measuring set-up, please contact ebmpapst. Suction-side noise levels: LwA measured as per ISO 13347 / LpA measured with 1m distance to fan axis. The values given are valid under the measuring conditions mentioned above and may vary according to the actual installation situation. With any deviation from the standard set-up, the specific values have to be checked and reviewed with the unit installed.

## Measured values

	Conn.	U	f	n	Pe	I	LpA <sub>in</sub>	LwA <sub>in</sub>	qv	ps
		V	Hz	min <sup>-1</sup>	W	A	dB(A)	dB(A)	m <sup>3</sup> /h	Pa
1	Y	400	60	1690	185	0.39	69	76	4615	0
2	Y	400	60	1660	223	0.45	70	76	4145	40
3	Y	400	60	1635	256	0.49	69	76	3580	80
4	Y	400	60	1605	290	0.54	70	76	2895	120

Conn. = Connection · U = Supply voltage · f = Frequency · n = Speed · Pe = Power input · I = Current draw · LpA<sub>in</sub> = Sound pressure level inlet side · LwA<sub>in</sub> = Sound power level inlet side  
qv = Air flow · ps = Pressure increase

