

AC axial fan

sickle-shaped blades (S series)
with guard grille for short nozzle

ebm-papst Mulfingen GmbH & Co. KG

Bachmühle 2 · D-74673 Mulfingen

Phone +49 7938 81-0

Fax +49 7938 81-110

sales@fansco.com

www.fansco.com

Limited partnership · Headquarters Mulfingen

Amtsgericht (court of registration) Stuttgart · HRA 590344

General partner Elektrobau Mulfingen GmbH · Headquarters Mulfingen

Amtsgericht (court of registration) Stuttgart · HRB 590142

Nominal data

| Type | S2E250-AL06-70 | | | |
|-----------------------------|--------------------|---------|---------|------|
| Motor | M2E068-CF | | | |
| Phase | | 1~ | 1~ | 1~ |
| Nominal voltage | VAC | 230 | 230 | 230 |
| Frequency | Hz | 50 | 60 | 60 |
| Method of obtaining data | | fa | fa | fa |
| Valid for approval/standard | | CE | CE | UL |
| Speed (rpm) | min ⁻¹ | 2500 | 2600 | 2600 |
| Power consumption | W | 120 | 160 | 175 |
| Current draw | A | 0.53 | 0.7 | 0.73 |
| Capacitor | µF | 3 | 3 | 3 |
| Capacitor voltage | VDB | 400 | 400 | 400 |
| Capacitor standard | | S0 (CE) | S0 (CE) | UL |
| Max. back pressure | Pa | 120 | 85 | 85 |
| Max. back pressure | inH ₂ O | 0.48 | 0.34 | 0.34 |
| Min. ambient temperature | °C | -25 | -25 | -25 |
| Max. ambient temperature | °C | 60 | 35 | 35 |
| Starting current | A | 0.88 | 0.87 | 0.87 |

ml = Max. load · me = Max. efficiency · fa = Free air · cs = Customer specification · ce = Customer equipment
Subject to change



AC axial fan

sickle-shaped blades (S series)
with guard grille for short nozzle

Technical description

| | |
|---|--|
| Weight | 2.5 kg |
| Fan size | 250 mm |
| Rotor surface | Painted black |
| Blade material | Sheet steel, painted black |
| Guard grille material | Steel, coated with black plastic (RAL 9005) |
| Number of blades | 7 |
| Airflow direction | "V" |
| Direction of rotation | Counterclockwise, viewed toward rotor |
| Degree of protection | IP44; installation- and position-dependent as per EN 60034-5 |
| Insulation class | "B" |
| Moisture (F) / Environmental (H) protection class | H0+ |
| Max. permitted ambient temp. for motor (transport/storage) | + 80 °C |
| Min. permitted ambient temp. for motor (transport/storage) | - 40 °C |
| Installation position | Any |
| Condensation drainage holes | On rotor side |
| Mode | S1 |
| Motor bearing | Ball bearing |
| Touch current according to IEC 60990 (measuring circuit Fig. 4, TN system) | < 0.75 mA |
| Motor protection | Thermal overload protector (TOP) internally connected |
| With cable | Variable |
| Protection class | I (with customer connection of protective earth) |
| Conformity with standards | EN 60335-1; CE |
| Approval | CSA C22.2 No. 100; UL 1004-1 |



AC axial fan

sickle-shaped blades (S series)
with guard grille for short nozzle

Product drawing

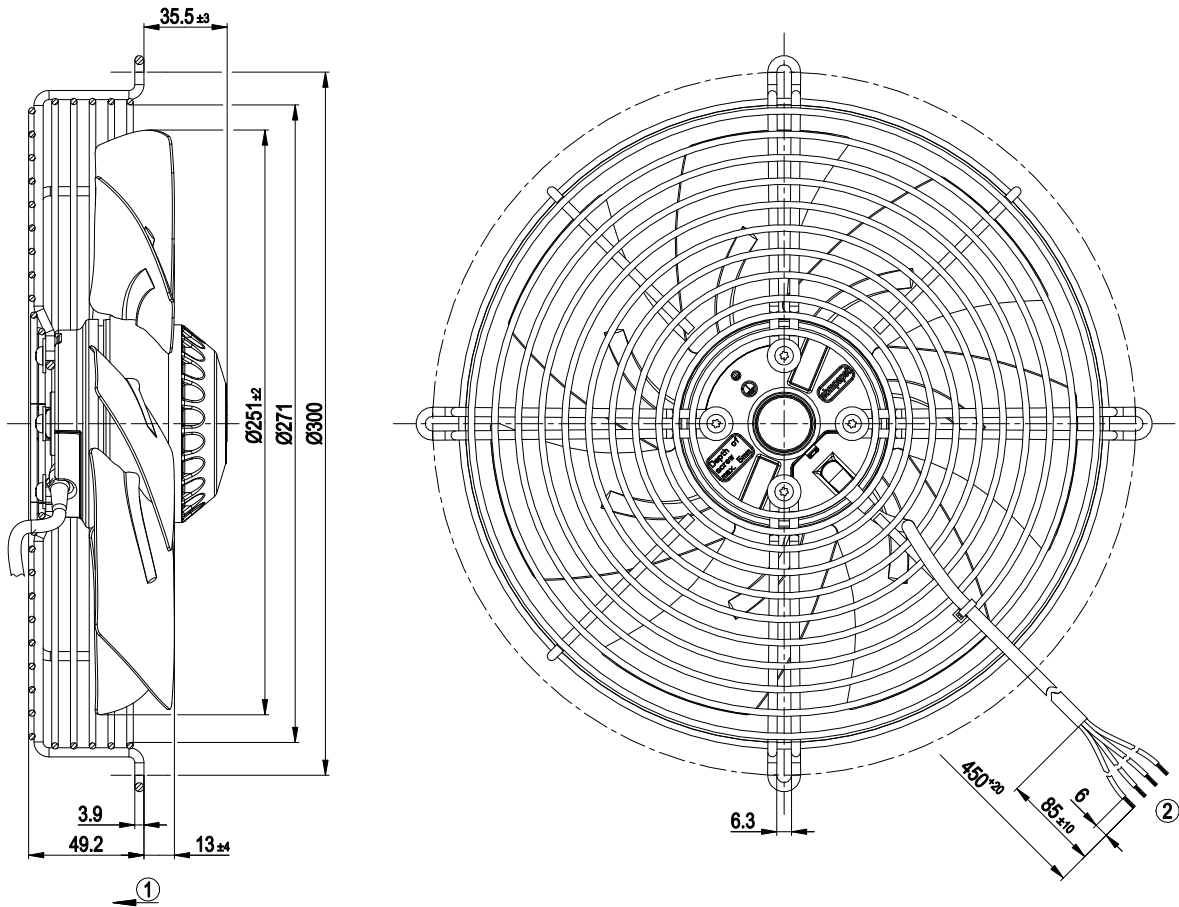

- 1 Direction of air flow "V"
- 2 Cable PVC AWG20, 4x crimped splices

Connection diagram

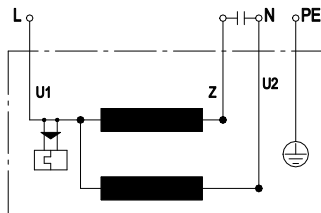

| | | | | | |
|----|--------------|---|-------|----|-------|
| U1 | blue | Z | brown | U2 | black |
| PE | green/yellow | | | | |



AC axial fan

sickle-shaped blades (S series)
with guard grille for short nozzle

Curves: Air performance 50 Hz

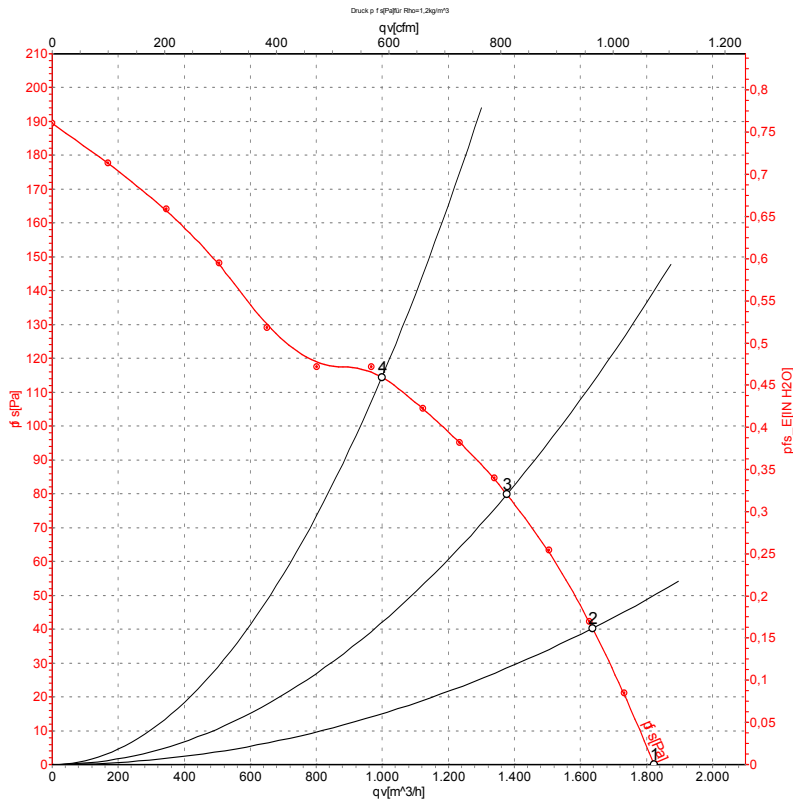

Measurement: LU-59608-1

Air performance measured according to ISO 5801 installation category A. For detailed information on the measurement setup, contact ebm-papst. Intake sound level: Sound power level according to ISO 13347 / sound pressure level measured at 1 m distance from fan axis. The values given are valid under the specified measuring conditions and may vary due to conditions of installation. For deviations from the standard configuration, the parameters have to be checked on the installed unit.

Measured values

| | U | f | n | P _e | I | q _v | p _{fs} | q _v | p _{fs} |
|---|-----|----|-------------------|----------------|------|-------------------|-----------------|----------------|--------------------|
| | V | Hz | min ⁻¹ | W | A | m ³ /h | Pa | cfm | inH ₂ O |
| 1 | 230 | 50 | 2450 | 115 | 0.51 | 1820 | 0 | 1070 | 0.00 |
| 2 | 230 | 50 | 2420 | 120 | 0.52 | 1635 | 40 | 965 | 0.16 |
| 3 | 230 | 50 | 2335 | 125 | 0.56 | 1375 | 80 | 810 | 0.32 |
| 4 | 230 | 50 | 2270 | 134 | 0.58 | 1000 | 115 | 585 | 0.46 |

U = Power supply · f = Frequency · n = Speed (rpm) · P_e = Power consumption · I = Current draw · q_v = Air flow · p_{fs} = Pressure increase



AC axial fan

sickle-shaped blades (S series)
with guard grille for short nozzle

Curves: Air performance 60 Hz

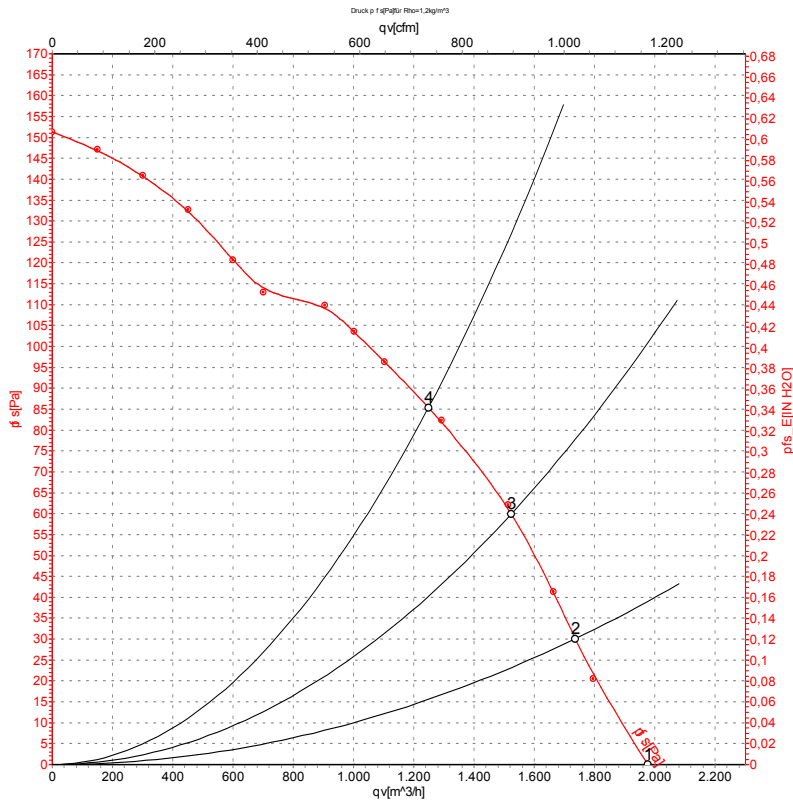

Measurement: LU-59609-1

Air performance measured according to ISO 5801 installation category A. For detailed information on the measurement setup, contact ebm-papst. Intake sound level: Sound power level according to ISO 13347 / sound pressure level measured at 1 m distance from fan axis. The values given are valid under the specified measuring conditions and may vary due to conditions of installation. For deviations from the standard configuration, the parameters have to be checked on the installed unit.

Measured values

| | U | f | n | P _e | I | q _v | P _{fs} | q _v | P _{fs} |
|---|-----|----|-------------------|----------------|------|-------------------|-----------------|----------------|-----------------|
| | V | Hz | min ⁻¹ | W | A | m ³ /h | Pa | cfm | inH2O |
| 1 | 230 | 60 | 2600 | 150 | 0.66 | 1970 | 0 | 1160 | 0.00 |
| 2 | 230 | 60 | 2525 | 156 | 0.68 | 1735 | 30 | 1020 | 0.12 |
| 3 | 230 | 60 | 2415 | 160 | 0.70 | 1525 | 60 | 895 | 0.24 |
| 4 | 230 | 60 | 2300 | 164 | 0.71 | 1250 | 85 | 735 | 0.34 |

U = Power supply · f = Frequency · n = Speed (rpm) · P_e = Power consumption · I = Current draw · q_v = Air flow · P_{fs} = Pressure increase

