

S2D250-BI02-01

AC axial fan

sickled blades (S series)

with guard grille for full nozzle



ebm-papst Mulfingen GmbH & Co. KG

Bachmühle 2

D-74673 Mulfingen

Phone: +49(0)7938/81-0

Fax: +49(0)7938/81-110

sales@fansco.com

www.fansco.com

Nominal data

Type	S2D250-BI02-01		
Motor	M2D068-CF		
Phase		3~	3~
Nominal voltage	[V]	400	400
Connection		Y	Y
Frequency	[Hz]	50	60
Type of data definition		rfa	rfa
Valid for approval / standard		CE	CE
Speed	[min ⁻¹]	2500	2650
Power input	[W]	100	140
Current draw	[A]	0.20	0.23
Max. back pressure	[Pa]	150	150
Max. ambient temperature	[°C]	65	45

ml = max. load · me = max. efficiency · rfa = running at free air · cs = customer specs · cu = customer unit
Subject to alterations

AC axial fan

sickled blades (S series)

with guard grille for full nozzle

Technical features

Leakage current	< 0.75 mA
Size	250 mm
Operation mode	S1
Direction of rotation	Counter-clockwise, seen on rotor
Mounting position	Shaft horizontal or rotor on bottom; rotor on top on request
Humidity class	F1-2
Direction of air flow	"A"
Insulation class	"B"
Cable exit	Lateral
Condensate discharge holes	Rotor-side
Bearing motor	Ball bearing
Mass	2.1 kg
Material of blades	Sheet steel, coated in black
Material of guard grille	Steel, phosphated and coated in black plastic
Product conforming to standard	EN 60335-1
Surface of rotor	Coated in black
Number of blades	7
Type of protection	IP 44
Protection class	I
Max. permissible ambient motor temp. (transp./ storage)	+ 80 °C
Min. permissible ambient motor temp. (transp./storage)	- 40 °C
Approval	CCC

S2D250-BI02-01

AC axial fan

sickled blades (S series)

with guard grille for full nozzle

Product drawing

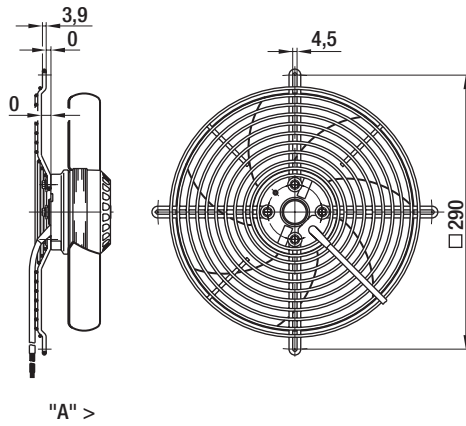

AC axial fan

sickled blades (S series)

with guard grille for full nozzle

Connection screen

Delta (3~ 230 VAC)

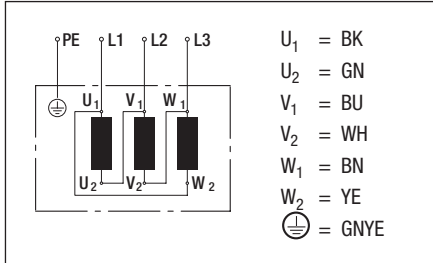

Star (3~ 400 VAC)

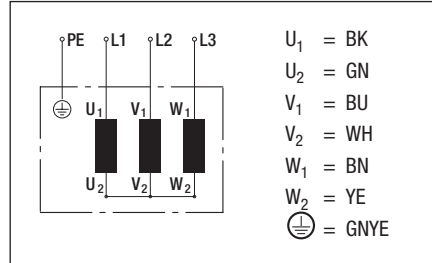

AC axial fan

sickled blades (S series)

with guard grille for full nozzle

Charts: Air flow 50 Hz

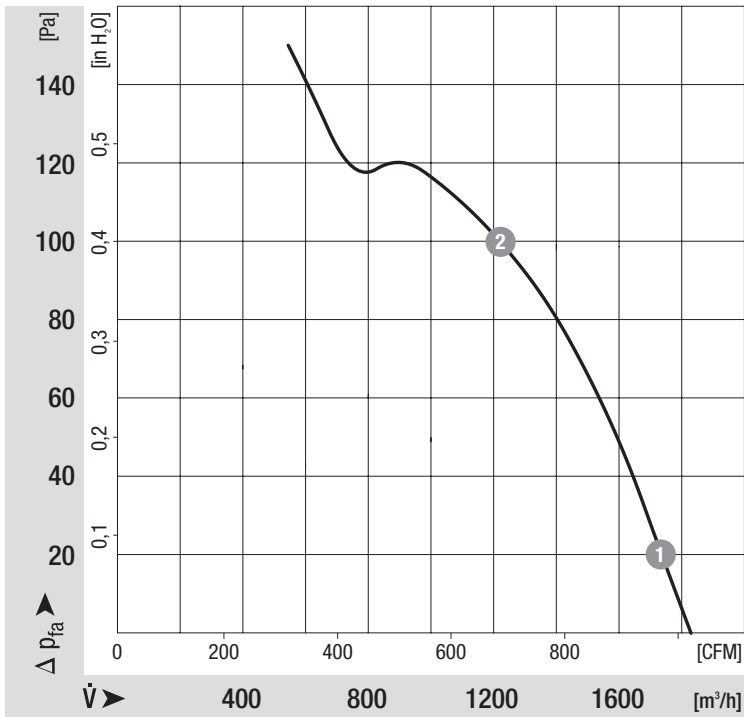

Measured values

	n	P ₁	I
	[min ⁻¹]	[W]	[A]
1	2455	106	0.20
2	2310	125	0.22

AC axial fan

sickled blades (S series)

with guard grille for full nozzle

Charts: Air flow 60 Hz

