

S1G200-CA91-02

EC axial fan - ESM

sickled blades (S series)

ESM guard grille



ebm-papst Mulfingen GmbH & Co. KG

Bachmühle 2 · D-74673 Mulfingen

Phone +49 7938 81-0

Fax +49 7938 81-110

sales@fansco.com

www.fansco.com

Limited partnership · Headquarters Mulfingen
County court Stuttgart · HRA 590344

General partner Elektrobau Mulfingen GmbH · Headquarters Mulfingen
County court Stuttgart · HRB 590142

Nominal data

Type	S1G200-CA91-02		
Motor	M1G055-BD		
Phase		1~	1~
Nominal voltage	VAC	230	230
Frequency	Hz	50/60	50/60
Type of data definition			ml
Speed	min ⁻¹	1500	2000
Power input	W	-	34
Current draw	A		0.26
Max. back pressure	Pa		45
Min. ambient temperature	°C	-30	-30
Max. ambient temperature	°C	50	50

ml = Max. load · me = Max. efficiency · fa = Running at free air · cs = Customer specs · cu = Customer unit
Subject to alterations



Technical features

Mass	0.95 kg
Size	200 mm
Material of impeller	PA plastic
Material of guard grille	Plastic, epylen GT50
Number of blades	5
Direction of air flow	"A"
Direction of rotation	Counter-clockwise, seen on rotor
Type of protection	IP 54
Insulation class	"B"
Humidity class	F3-1
Max. permissible ambient motor temp. (transp./ storage)	+80 °C
Min. permissible ambient motor temp. (transp./storage)	-40 °C
Mounting position	Any
Condensate discharge holes	None
Operation mode	S1
Motor bearing	Ball bearing
Technical features	<ul style="list-style-type: none"> - Over-temperature protected motor - Soft start - Speed selection max/min
Speed steps	2
EMC interference immunity	Acc. to EN 61000-6-2 (industrial environment)
EMC harmonics	Acc. to EN 61000-3-2/3
EMC interference emission	Acc. to EN 61000-6-3 (household environment)
Motor protection	Thermal overload protector (TOP) wired internally
Cable exit	Lateral
Protection class	II
Product conforming to standard	EN 60335-1; CE
Approval	CCC; CSA C22.2 Nr.77; EAC; UL 2111; VDE

EC axial fan - ESM

sickled blades (S series)

ESM guard grille

Product drawing

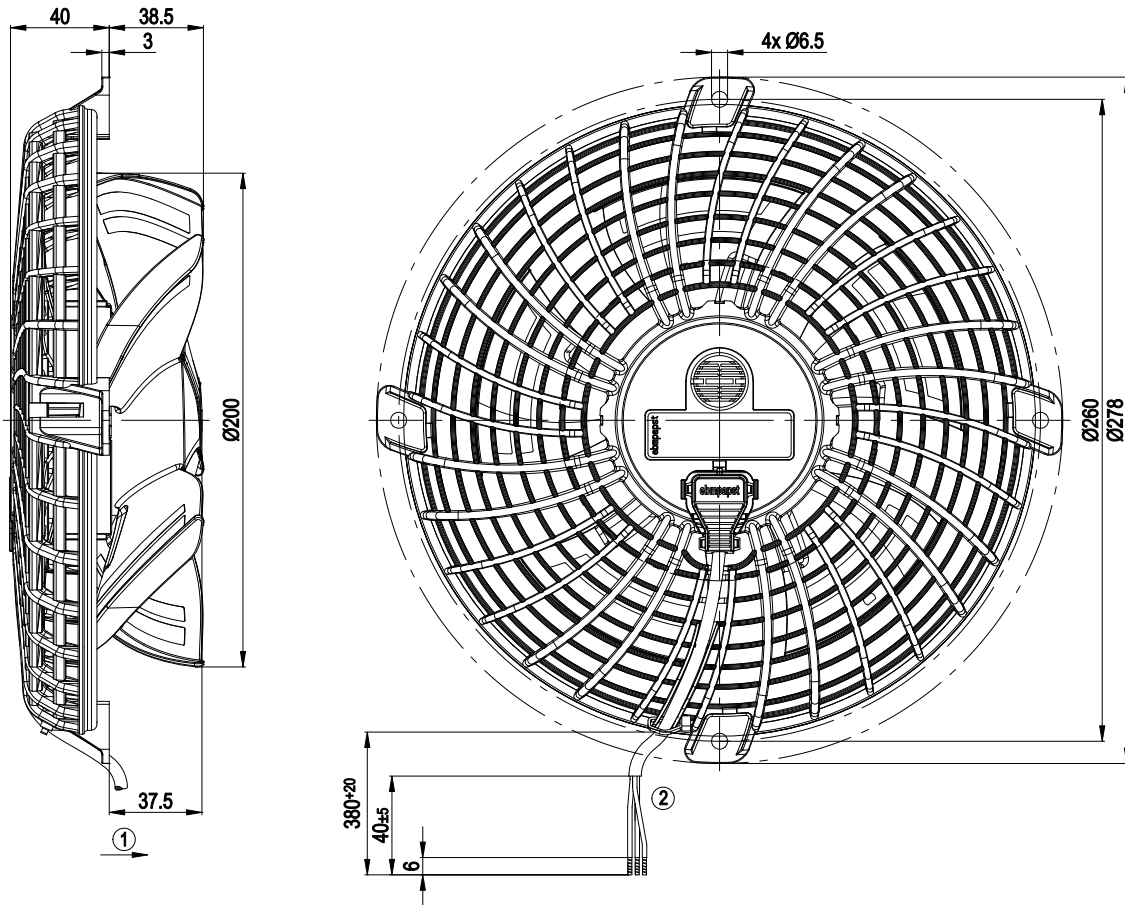

- 1 Direction of air flow "A"
- 2 Connection line AWG20; 3x lead tips crimped

Connection screen

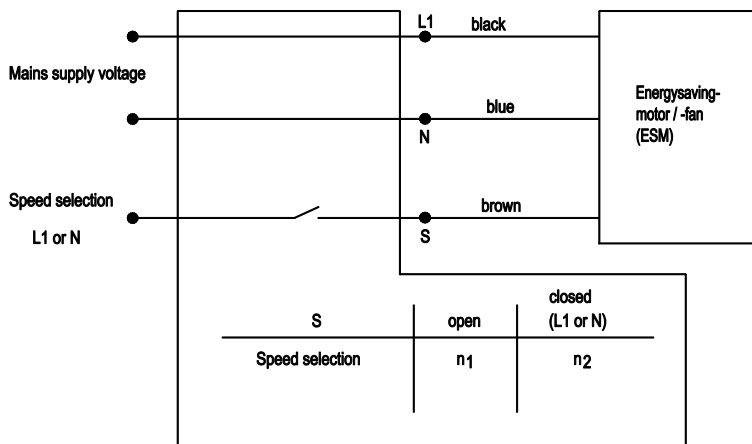

Charts: Air flow 50 Hz

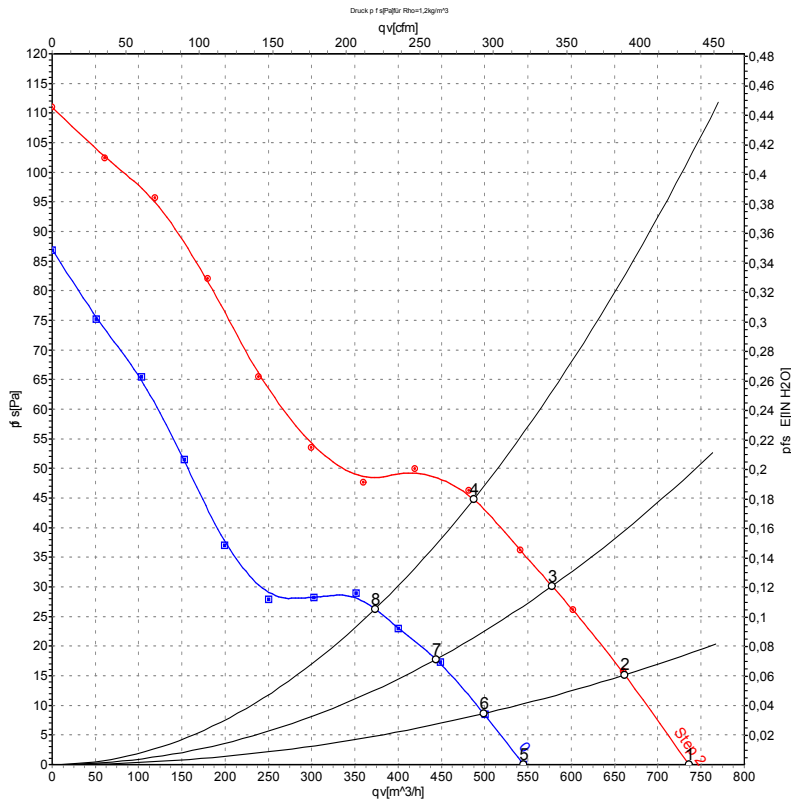

Air performance measured as per ISO 5801 Installation category A. For detailed information on the measuring set-up, please contact ebmpapst. Suction-side noise levels: LwA measured as per ISO 13347 / LpA measured with 1m distance to fan axis. The values given are valid under the measuring conditions mentioned above and may vary according to the actual installation situation. With any deviation from the standard set-up, the specific values have to be checked and reviewed with the unit installed.

Measured values

	Stage	U	f	n	P _{ed}	I	LpA _{in}	LwA _{in}	qv	p _{fs}
		V	Hz	min ⁻¹	W	A	dB(A)	dB(A)	m ³ /h	Pa
1	2	230	50	2000	32	0.24	54	64	735	0
2	2	230	50	2000	33	0.25	54	64	660	15
3	2	230	50	2000	33	0.26	53	63	580	30
4	2	230	50	2000	34	0.26	54	64	485	45
5	2	230	50	1500	18	0.16	50	59	545	0
6	2	230	50	1500	19	0.16	50	58	500	9
7	2	230	50	1500	19	0.16	49	58	445	18
8	2	230	50	1500	20	0.16	50	59	375	26

U = Supply voltage · f = Frequency · n = Speed · P_{ed} = Power input · I = Current draw · LpA_{in} = Sound pressure level inlet side · LwA_{in} = Sound power level inlet side · qv = Air flow
 p_s = Pressure increase

