

RL 65-21/14

DC centrifugal compact fan

single-intake



ebm-papst St. Georgen GmbH & Co. KG

Hermann-Papst-Str. 1

D-78112 St. Georgen

Phone +49 (0) 7724 81-0

Fax +49 (0) 7724 81-1309

sales@fansco.com

www.fansco.com

Nominal data

Type	RL 65-21/14	
Nominal voltage	VDC	24
Nominal voltage range	VDC	12 .. 26.4
Speed (rpm)	min ⁻¹	4500
Power consumption	W	14
Min. ambient temperature	°C	-20
Max. ambient temperature	°C	70
Air flow	m ³ /h	56
Sound power level	B	6.6

ml = Max. load · me = Max. efficiency · fa = Free air · cs = Customer specification · ce = Customer equipment
Subject to change



DC centrifugal compact fan

single-intake

Technical description

General description	Forward-curved impeller
Weight	0.170 kg
Dimensions	97 x 93.5 x 33 mm
Impeller material	Glass-fiber reinforced plastic
Housing material	Scroll housing with glass-fiber reinforced plastic.
Airflow direction	Axial intake, radial discharge from outlet.
Storage	Ball bearing
Service life L10 at 40 °C	60000 h
Service life L10 at maximum temperature	30000 h
Cable	With leads AWG 26, TR 64
Motor protection	Protection against reverse polarity and blocked rotor.



Product drawing

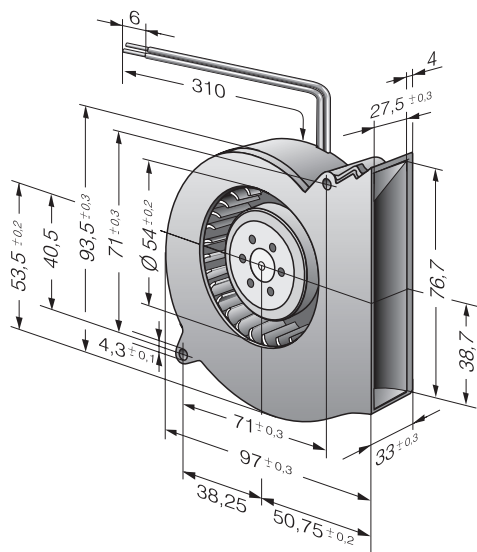

Curves: Air performance

