

R3G280-AA52-01

EC centrifugal fan

backward curved, single inlet

ebm-papst Mulfingen GmbH & Co. KG

Bachmühle 2

D-74673 Mulfingen

Phone +49 7938 81-0

Fax +49 7938 81-110

sales@fansco.com

www.fansco.com

Nominal data

Type	R3G280-AA52-01	
Motor	M3G074-CF	
Phase		1~
Nominal voltage	VAC	230
Nominal voltage range	VAC	200 .. 277
Frequency	Hz	50
Type of data definition		rfa
Speed	min ⁻¹	2000
Power input	W	145
Current draw	A	1.1
Min. ambient temperature	°C	-25
Max. ambient temperature	°C	60

ml = max. load · me = max. efficiency · rfa = running at free air · cs = customer specs · cu = customer unit
Subject to alterations

Technical features

Leakage current	<= 3.5 mA
General description	Integrated electronics
Size	280 mm
Operation mode	S1
Direction of rotation	Clockwise, seen on rotor
Mounting position	Any
EMC harmonics	Acc. to EN 61000-3-2/3
EMC interference emission	Acc. to EN 61000-6-3 (household environment)
EMC interference immunity	Acc. to EN 61000-6-2 (industrial environment)
Humidity class	F3-1
Insulation class	"B"
Cable exit	Variable
Condensate discharge holes	None
Motor bearing	Ball bearing
Mass	3.35 kg
Material of electronics housing	Die-cast aluminium
Material of impeller	Sheet steel, galvanised
Motor protection	Thermal overload protector (TOP) wired internally
Product conforming to standard	EN 60335-1; EN 61800-5-1; EN 60950-1
Surface of rotor	Galvanised
Number of blades	11
Type of protection	IP 44
Protection class	I
Technical features	<ul style="list-style-type: none"> - Output 10 VDC, max. 1.1 mA - Tach output - Motor current limit - Soft start - Control input 0-10 VDC / PWM - Over-temperature protected electronics / motor
Max. permissible ambient motor temp. (transp./ storage)	+80 °C
Min. permissible ambient motor temp. (transp./storage)	-40 °C
Approval	CSA C22.2 Nr.77; UL 2111

Product drawing

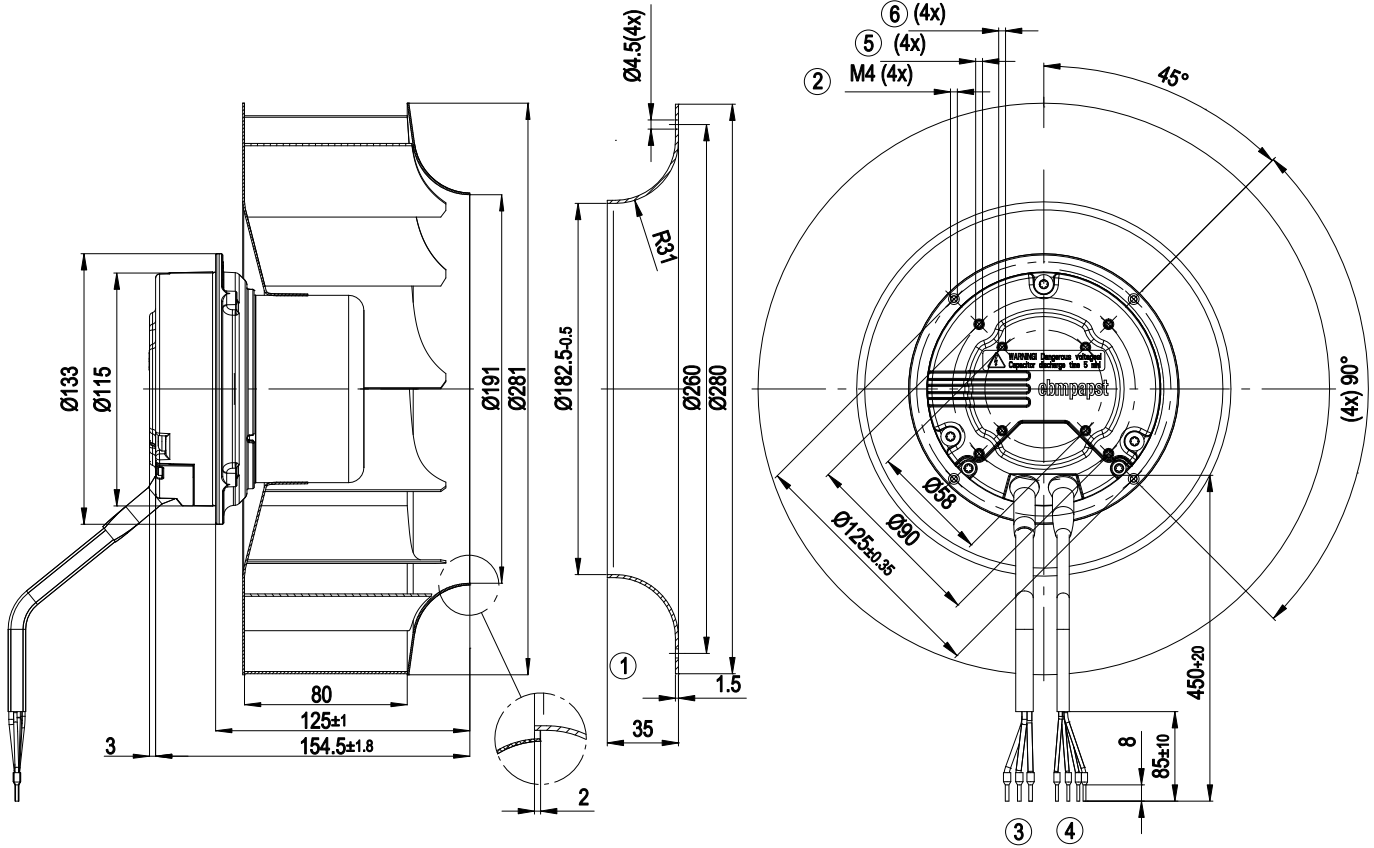

1	Accessory part: inlet nozzle 96360-2-4013 not included in the standard scope of delivery; other inlet nozzles on request
2	Depth of screw 8-10 mm
3	Connection line AWG18, 3 x crimped core-end sleeves
4	Connection line AWG22, 4 x crimped core-end sleeves
5	Pilot hole prepared for self-tapping screw M4, depth of screw max. 6 mm
6	Pilot hole prepared for self-tapping screw M4, depth of screw max. 6 mm

Connection screen

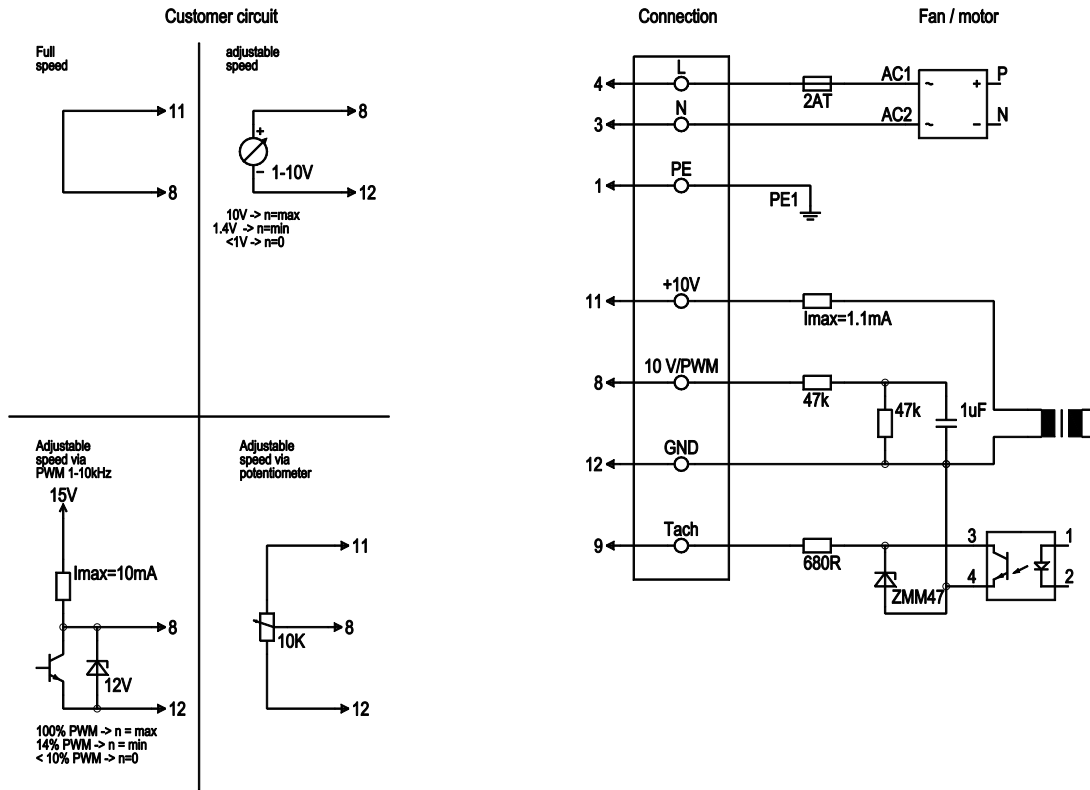

Line	No.	Signal	Colour	Function / assignment
	4	L	black	Power supply 230 VAC, 50-60 Hz, see type plate for voltage range
	3	N	blue	Neutral conductor
	1	PE	green/yellow	Protective earth
	8	0-10 V PWM	yellow	Control input 0 - 10 V or PWM, electrically isolated
	9	Tach	white	Tach output: open collector, 1 pulse per revolution, electrically isolated
	11	10V / max 1.1 mA	red	Voltage output 10 V / max. 1.1 mA, electrically isolated
	12	GND	blue	GND - Connection for control interface

Charts: Air flow 50 Hz

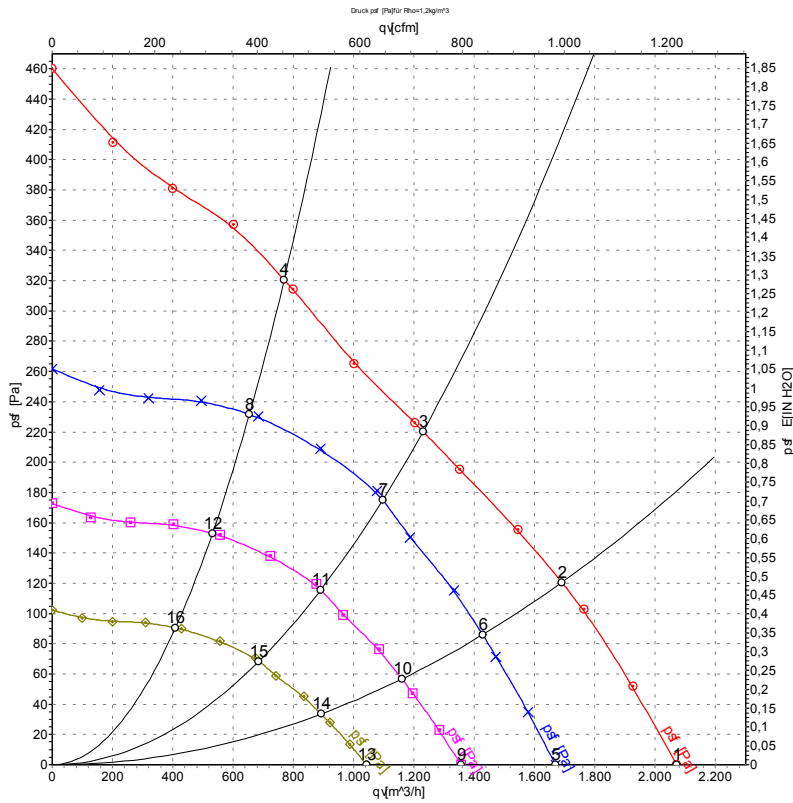

Measurement: LU-72157

Air performance measured as per ISO 5801 Installation Category A. For detailed information on the measuring set-up, please contact ebm-papst. Suction-side noise levels: LwA measured as per ISO 13347 / LpA measured with 1m distance to fan axis. The values given are valid under the measuring conditions mentioned above and may vary according to the actual installation situation. With any deviation from the standard set-up, the specific values have to be checked and reviewed with the unit installed.

Measured values

	U	f	n	Pe	I	qv	Psf
	V	Hz	min ⁻¹	W	A	m ³ /h	Pa
1	230	50	2000	145	1.10	2070	0
2	230	50	1895	168	1.22	1690	120
3	230	50	1795	170	1.25	1230	220
4	230	50	1880	165	1.21	770	320
5	230	50	1600	75	0.55	1670	0
6	230	50	1600	101	0.74	1425	86
7	230	50	1600	121	0.89	1095	176
8	230	50	1600	101	0.74	655	232
9	230	50	1300	40	0.30	1355	0
10	230	50	1300	54	0.40	1160	57
11	230	50	1300	65	0.48	890	116
12	230	50	1300	54	0.40	530	153
13	230	50	1000	18	0.13	1045	0
14	230	50	1000	25	0.18	890	34
15	230	50	1000	30	0.22	685	69
16	230	50	1000	25	0.18	410	91