

AC centrifugal fan

backward-curved, single-intake

ebm-papst Mulfingen GmbH & Co. KG

Bachmühle 2 · D-74673 Mulfingen

Phone +49 7938 81-0

Fax +49 7938 81-110

sales@fansco.com

www.fansco.com

Limited partnership · Headquarters Mulfingen

Amtsgericht (court of registration) Stuttgart · HRA 590344

General partner Elektrobau Mulfingen GmbH · Headquarters Mulfingen

Amtsgericht (court of registration) Stuttgart · HRB 590142

Nominal data

Type	R2E250-AL03-10	
Motor	M2E068-GA	
Phase		1~
Nominal voltage	VAC	230
Frequency	Hz	60
Method of obtaining data		fa
Valid for approval/standard		CE
Speed (rpm)	min ⁻¹	3000
Power consumption	W	315
Current draw	A	1.4
Capacitor	µF	7
Capacitor voltage	VDB	450
Min. back pressure	Pa	0
Min. back pressure	inH ₂ O	0
Min. ambient temperature	°C	-25
Max. ambient temperature	°C	35
Starting current	A	2.5

ml = Max. load · me = Max. efficiency · fa = Free air · cs = Customer specification · ce = Customer equipment
Subject to change



Technical description

Weight	4.1 kg
Fan size	250 mm
Impeller material	Sheet steel, hot-dip galvanized
Number of blades	11
Direction of rotation	Clockwise, viewed toward rotor
Degree of protection	IP00; (motor)
Insulation class	"B"
Moisture (F) / Environmental (H) protection class	H0 - dry environment
Max. permitted ambient temp. for motor (transport/storage)	+ 80 °C
Min. permitted ambient temp. for motor (transport/storage)	- 40 °C
Installation position	Any
Condensation drainage holes	None, open rotor
Mode	S1
Motor bearing	Ball bearing
Touch current according to IEC 60990 (measuring circuit Fig. 4, TN system)	< 0.75 mA
Motor protection	Thermal overload protector (TOP) internally connected
With cable	Variable
Protection class	I (with customer connection of protective earth)
Conformity with standards	EN 60335-1; CE
Approval	UL 2111

Product drawing

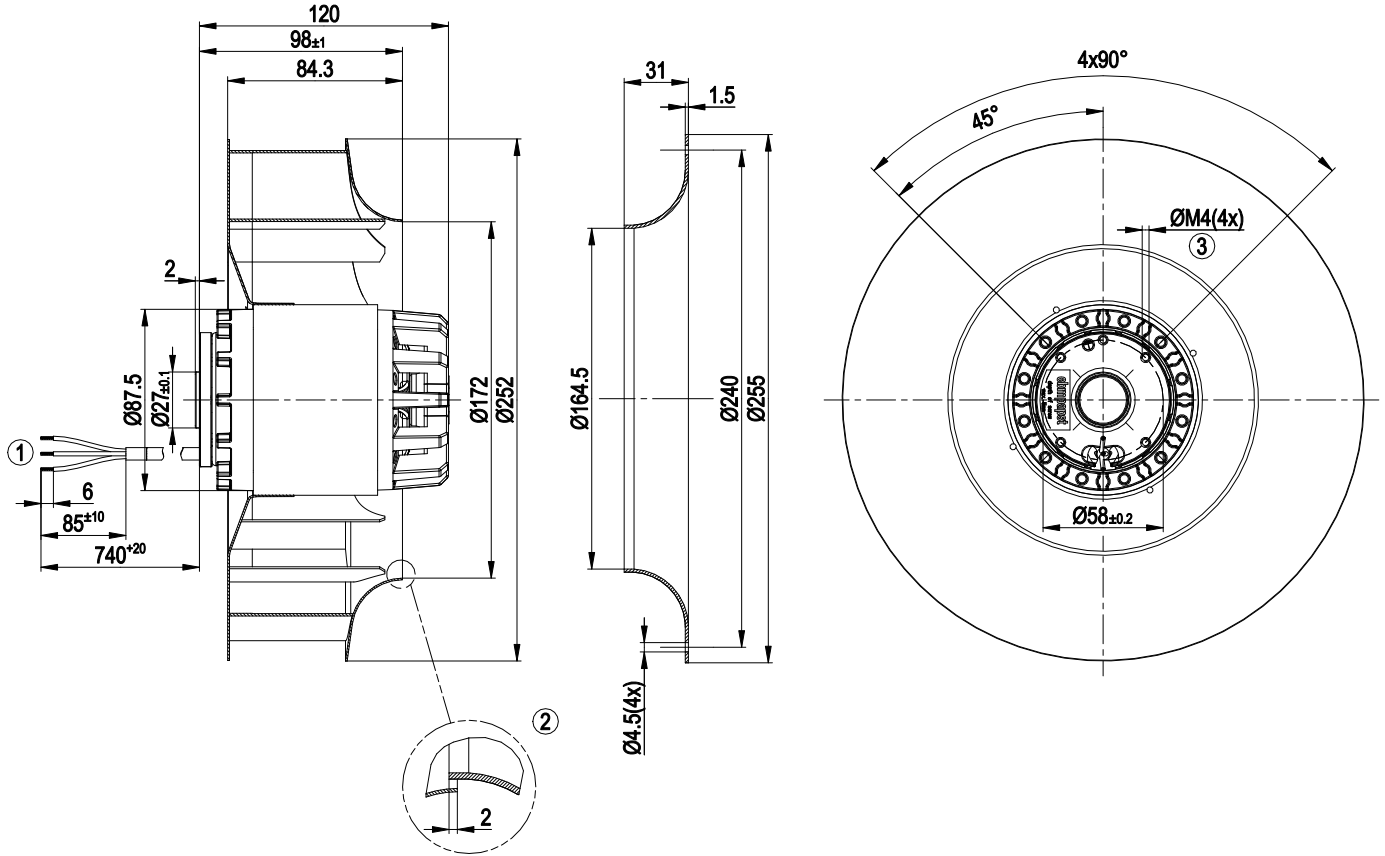

- | | |
|---|--|
| 1 | Cable AWG20 3x 0.5 mm ² , 3x crimped splices |
| 2 | Accessory part: inlet ring 96359-2-4013, not included in scope of delivery |
| 3 | Max. clearance for screw 5 mm |

Connection diagram

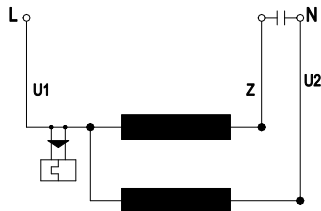

- | | | | | | |
|----|------|---|-------|----|-------|
| U1 | blue | Z | brown | U2 | black |
|----|------|---|-------|----|-------|

Curves: Air performance 60 Hz

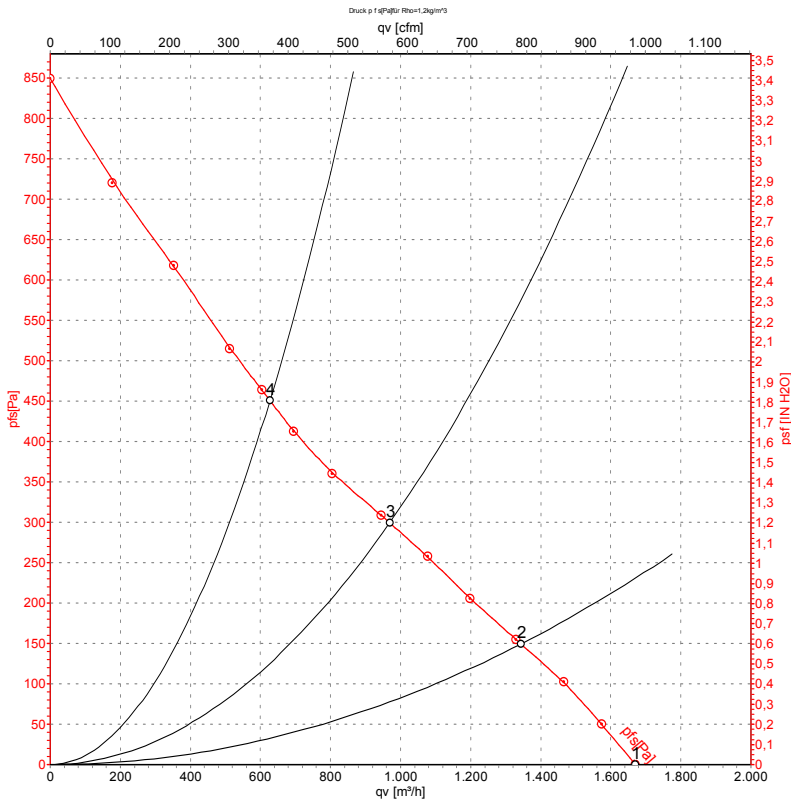

Measurement: LU-16409-1

Air performance measured according to ISO 5801 installation category A. For detailed information on the measurement setup, contact ebm-papst. Intake sound level: Sound power level according to ISO 13347 / sound pressure level measured at 1 m distance from fan axis. The values given are valid under the specified measuring conditions and may vary due to conditions of installation. For deviations from the standard configuration, the parameters have to be checked on the installed unit.

Measured values

	U	f	n	P _e	I	qv	p _{fs}	qv	p _{fs}
	V	Hz	min ⁻¹	W	A	m ³ /h	Pa	CFM	inH ₂ O
1	230	60	3000	315	1.40	1670	0	985	0.00
2	230	60	2750	334	1.46	1345	150	790	0.60
3	230	60	2630	348	1.52	970	300	570	1.20
4	230	60	2650	345	1.50	625	450	370	1.81

U = Power supply · f = Frequency · n = Speed (rpm) · P_e = Power consumption · I = Current draw · qv = Air flow · p_{fs} = Pressure increase

