

ebm-papst Mulfingen GmbH & Co. KG

Bachmühle 2 · D-74673 Mulfingen

Phone +49 7938 81-0

Fax +49 7938 81-110

sales@fansco.com

www.fansco.com

Limited partnership · Headquarters Mulfingen

Amtsgericht (court of registration) Stuttgart · HRA 590344

General partner Elektrobau Mulfingen GmbH · Headquarters Mulfingen

Amtsgericht (court of registration) Stuttgart · HRB 590142

Nominal data

Type	R2E225-BD92-19		
Motor	M2E068-DF		
Phase		1~	1~
Nominal voltage	VAC	230	230
Frequency	Hz	50	60
Method of obtaining data		fa	fa
Valid for approval/standard		-	-
Speed (rpm)	min ⁻¹	2650	2950
Power consumption	W	135	200
Current draw	A	0.6	0.88
Capacitor	µF	4	4
Capacitor voltage	VDB	450	450
Min. back pressure	Pa	0	0
Min. back pressure	in. wg	0	0
Min. ambient temperature	°C	-25	-25
Max. ambient temperature	°C	55	55
Starting current	A	1.2	1.2

ml = Max. load · me = Max. efficiency · fa = Free air · cs = Customer specification · ce = Customer equipment
Subject to change



Technical description

Weight	2.3 kg
Fan size	225 mm
Rotor surface	Painted black
Impeller material	PA6 plastic, glass-fiber reinforced
Number of blades	7
Direction of rotation	Clockwise, viewed toward rotor
Degree of protection	IP44
Insulation class	"F"
Moisture (F) / Environmental (H) protection class	H0+
Max. permitted ambient temp. for motor (transport/storage)	+ 80 °C
Min. permitted ambient temp. for motor (transport/storage)	- 40 °C
Installation position	Shaft horizontal or rotor on bottom; rotor on top on request
Condensation drainage holes	On rotor side
Mode	S1
Motor bearing	Ball bearing
Touch current according to IEC 60990 (measuring circuit Fig. 4, TN system)	< 0.75 mA
Motor protection	Thermal overload protector (TOP) internally connected
With cable	Variable
Protection class	I (with customer connection of protective earth)
Conformity with standards	EN 60335-1
Approval	CCC; CSA C22.2 No. 100; UL 1004-1; EAC

Product drawing

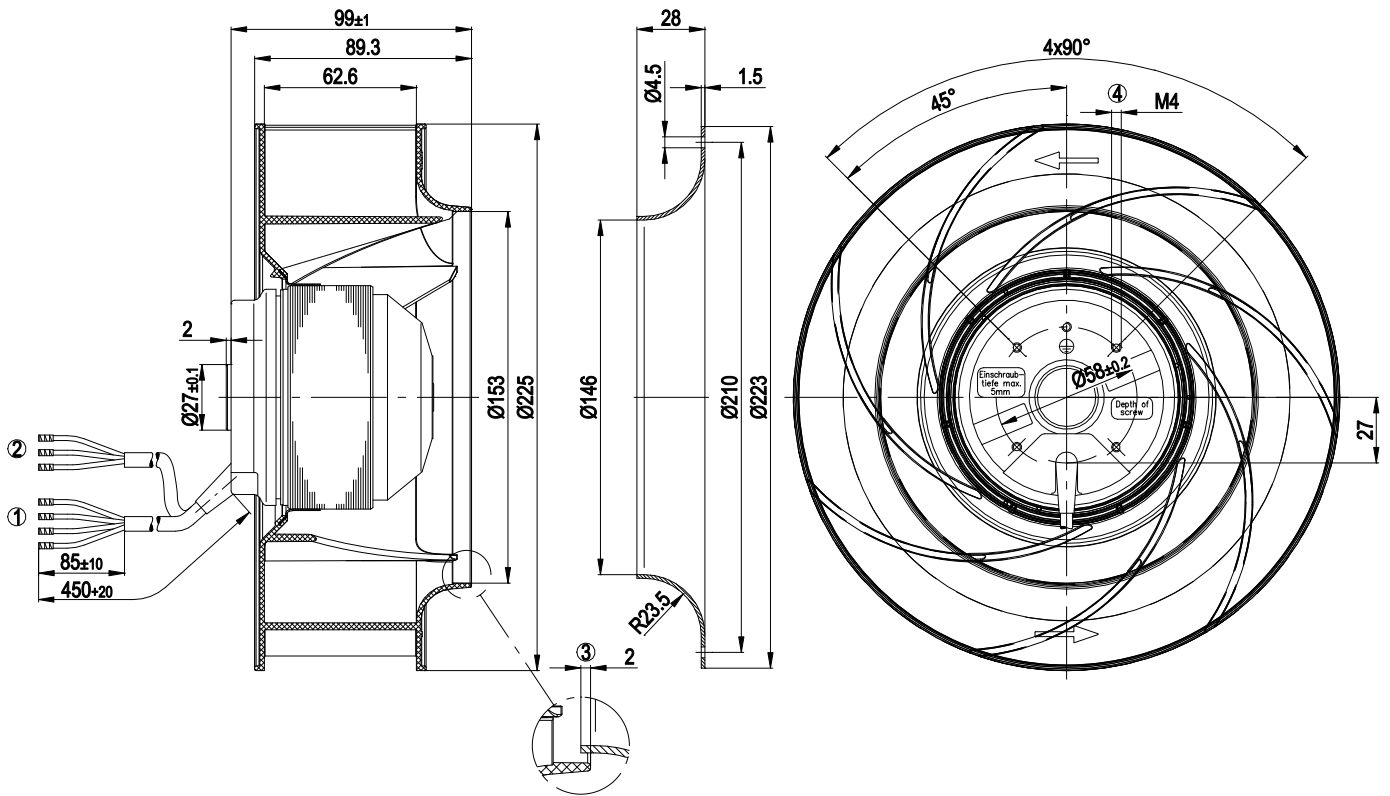

1	Cable PVC, 4x crimped splices
2	Cable, 3x crimped splices
3	Accessory part: inlet ring 96358-2-4013, not included in scope of delivery
4	Max. clearance for screw 5 mm

Connection diagram

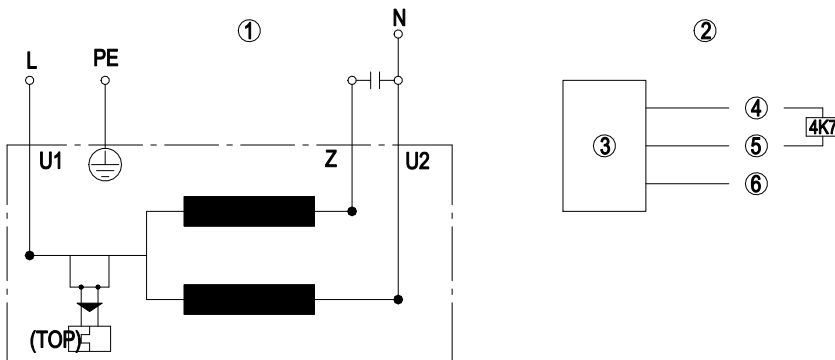

1	Fan connection diagram
TOP	Thermal overload protector
U1	blue
Z	brown
U2	black
PE	green/yellow
2	Hall IC circuit
3	fan
4	red (+5 V)
5	white (out)
6	black (0 V)

Curves: Air performance 50 Hz

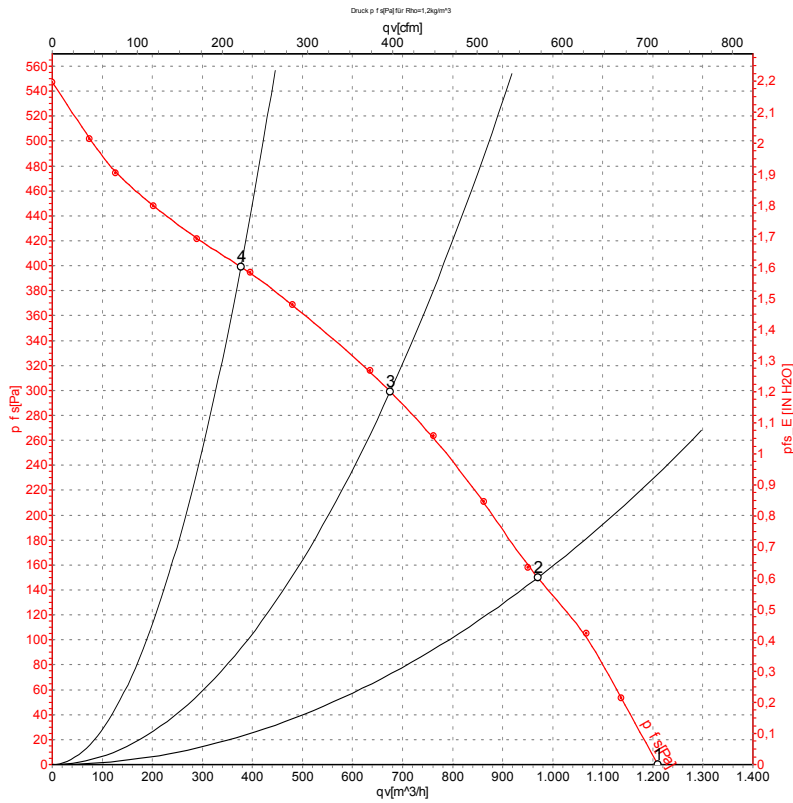

Measurement: LU-57084-1

Air performance measured according to ISO 5801 installation category A. For detailed information on the measurement setup, contact ebm-papst. Intake sound level: Sound power level according to ISO 13347 / sound pressure level measured at 1 m distance from fan axis. The values given are valid under the specified measuring conditions and may vary due to conditions of installation. For deviations from the standard configuration, the parameters have to be checked on the installed unit.

Measured values

	U	f	n	P _e	I	q _v	P _{is}	q _v	P _{is}
	V	Hz	min ⁻¹	W	A	m ³ /h	Pa	cfm	in. wg
1	230	50	2700	135	0.60	1210	0	710	0.00
2	230	50	2660	138	0.60	970	150	570	0.60
3	230	50	2595	150	0.65	675	300	395	1.20
4	230	50	2645	140	0.61	375	400	220	1.61

U = Power supply · f = Frequency · n = Speed (rpm) · P_e = Power consumption · I = Current draw · q_v = Air flow · P_{is} = Pressure increase



Curves: Air performance 60 Hz

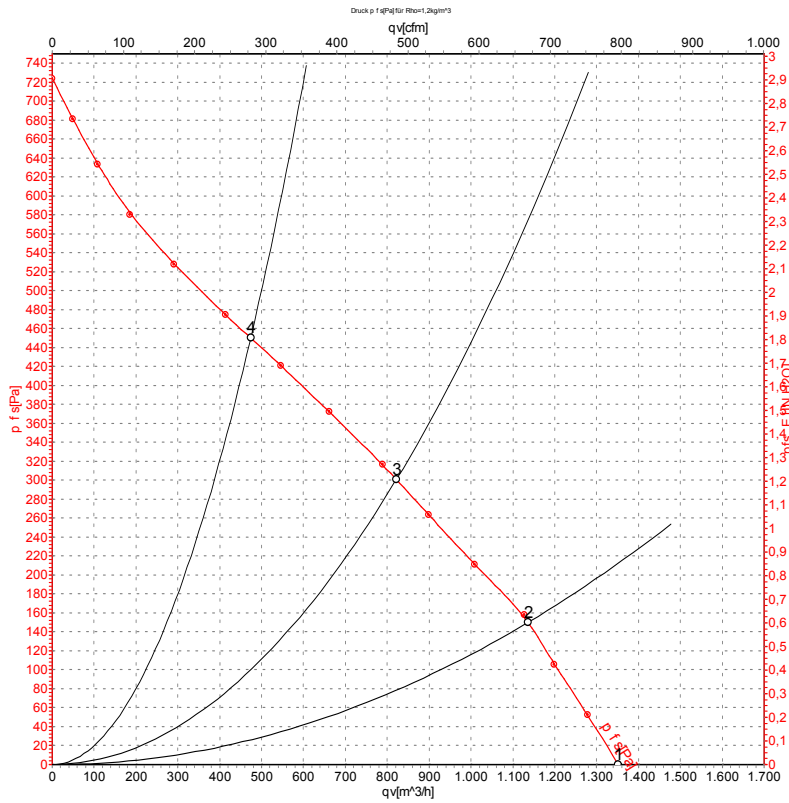

Measurement: LU-57085-1

Air performance measured according to ISO 5801 installation category A. For detailed information on the measurement setup, contact ebm-papst. Intake sound level: Sound power level according to ISO 13347 / sound pressure level measured at 1 m distance from fan axis. The values given are valid under the specified measuring conditions and may vary due to conditions of installation. For deviations from the standard configuration, the parameters have to be checked on the installed unit.

Measured values

	U	f	n	P _e	I	q _v	P _{fs}	q _v	P _{fs}
	V	Hz	min ⁻¹	W	A	m ³ /h	Pa	cfm	in. wg
1	230	60	2950	200	0.88	1350	0	795	0.00
2	230	60	2910	207	0.91	1135	150	670	0.60
3	230	60	2795	216	0.94	820	300	485	1.20
4	230	60	2845	210	0.92	475	450	280	1.81

U = Power supply · f = Frequency · n = Speed (rpm) · P_e = Power consumption · I = Current draw · q_v = Air flow · P_{fs} = Pressure increase

