

R2E225-AT51-14

AC centrifugal fan

backward-curved, single-intake



Nominal data

Type	R2E225-AT51-14			
Motor	M2E068-DF			
Phase		1~	1~	1~
Nominal voltage	VAC	230	230	230
Frequency	Hz	50	60	60
Method of obtaining data		fa	fa	fa
Valid for approval/standard		CE	CE	UL 2111
Speed (rpm)	min ⁻¹	2650	2950	2950
Power consumption	W	105	145	155
Current draw	A	0.46	0.64	0.66
Capacitor	μF	3	3	3
Capacitor voltage	VDB	450	450	450
Min. back pressure	Pa	0	0	0
Min. back pressure	inH ₂ O	0	0	0
Min. ambient temperature	°C	-25	-25	-25
Max. ambient temperature	°C	55	55	55
Starting current	A	1.05	1.04	1.04

ml = Max. load · me = Max. efficiency · fa = Free air · cs = Customer specification · ce = Customer equipment
Subject to change



Technical description

Weight	2.34 kg
Fan size	225 mm
Rotor surface	Painted black
Impeller material	PA6 plastic, glass-fiber reinforced
Number of blades	11
Direction of rotation	Clockwise, viewed toward rotor
Degree of protection	IP44; installation- and position-dependent as per EN 60034-5
Insulation class	"B"
Moisture (F) / Environmental (H) protection class	H0+
Max. permitted ambient temp. for motor (transport/storage)	+ 80 °C
Min. permitted ambient temp. for motor (transport/storage)	- 40 °C
Installation position	Shaft horizontal or rotor on bottom; rotor on top on request
Condensation drainage holes	On rotor side
Mode	S1
Motor bearing	Ball bearing
Touch current according to IEC 60990 (measuring circuit Fig. 4, TN system)	< 0.75 mA
Motor protection	Thermal overload protector (TOP) with basic insulation
With cable	Variable
Protection class	I (with customer connection of protective earth)
Conformity with standards	EN 60335-1; CE
Approval	CCC; UL 2111; CSA C22.2 No. 77

AC centrifugal fan

backward-curved, single-intake

Product drawing

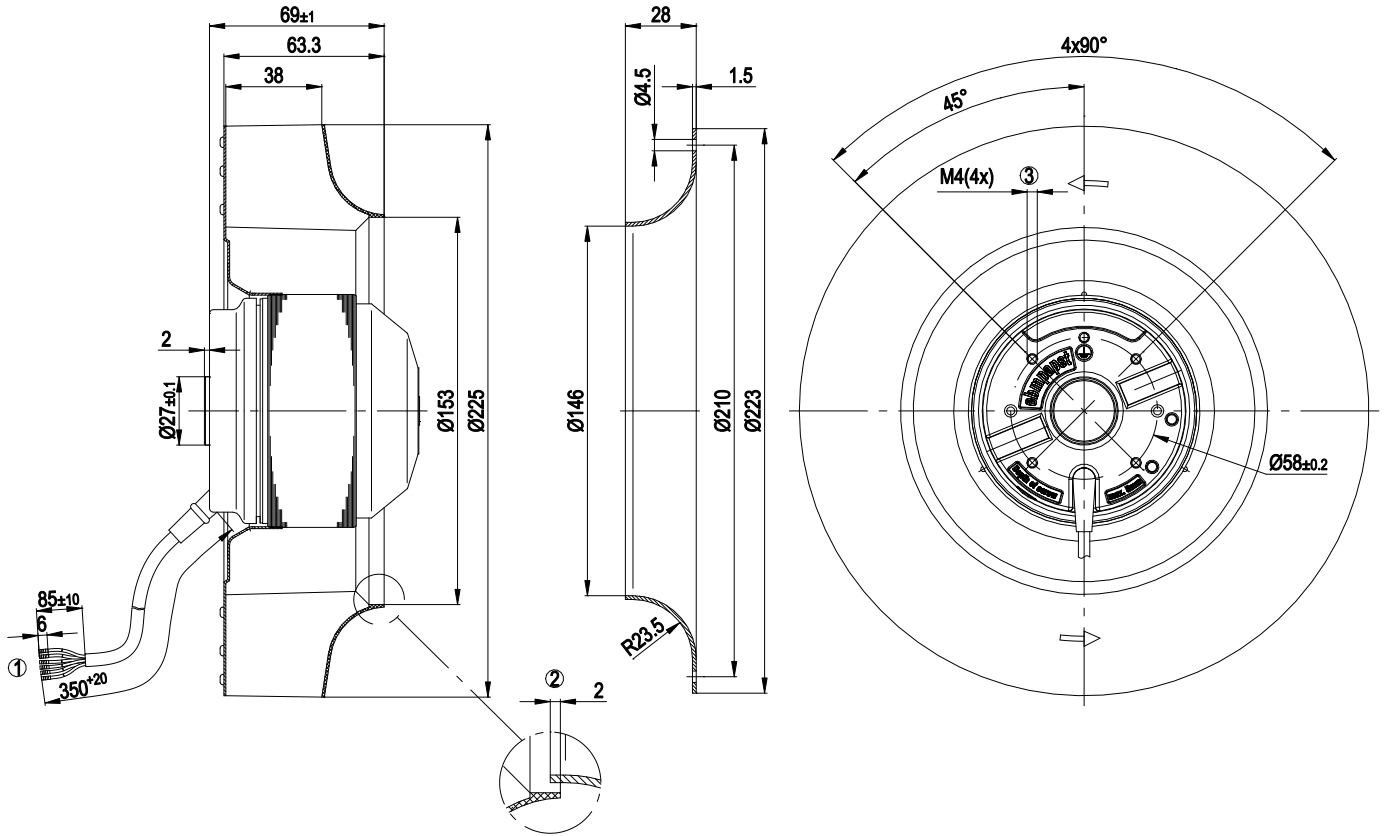

1	Cable PVC 6G AWG20, 4x crimped splices
2	Accessory part: Inlet ring 96358-2-4013, not included in scope of delivery
3	Max. clearance for screw 5 mm
	Capacitor 94773-4-7320 (3 µF 400 VDB) included separately



Connection diagram

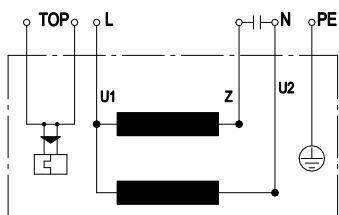

U1	blue	Z	brown	U2	black
PE	green/yellow	TOP	2x white		

Curves: Air performance 50 Hz

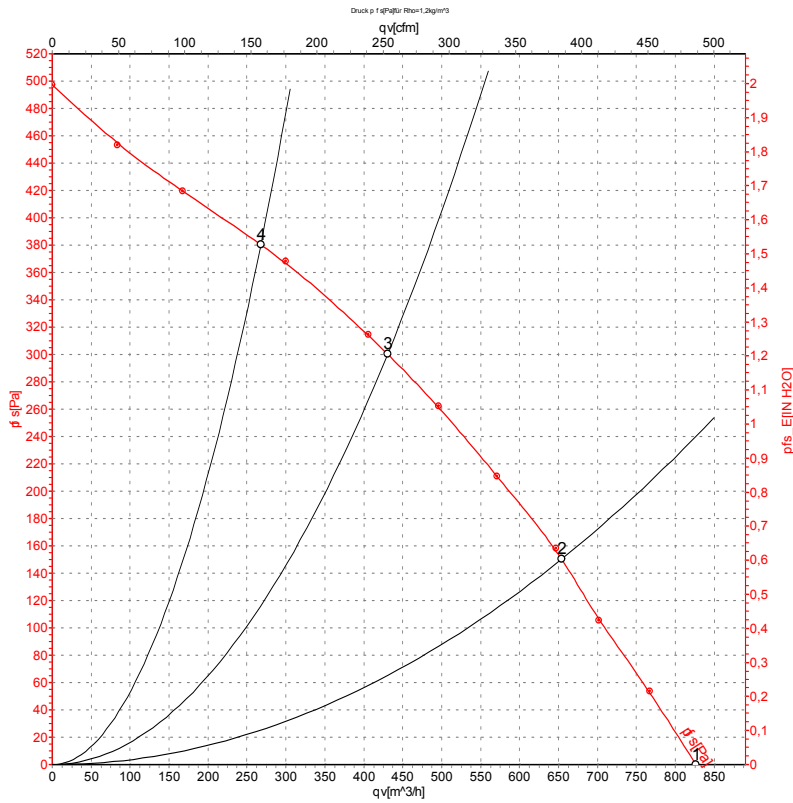

Measurement: LU-57249-1

Air performance measured according to ISO 5801 installation category A. For detailed information on the measurement setup, contact ebm-papst. Intake sound level: Sound power level according to ISO 13347 / sound pressure level measured at 1 m distance from fan axis. The values given are valid under the specified measuring conditions and may vary due to conditions of installation. For deviations from the standard configuration, the parameters have to be checked on the installed unit.

Measured values

	U	f	n	P _e	I	qv	p _{fs}	qv	p _{fs}
	V	Hz	min ⁻¹	W	A	m ³ /h	Pa	CFM	inH2O
1	230	50	2650	105	0.46	825	0	485	0.00
2	230	50	2595	111	0.49	655	150	385	0.60
3	230	50	2585	112	0.50	430	300	255	1.20
4	230	50	2650	103	0.46	270	380	160	1.53

U = Power supply · f = Frequency · n = Speed (rpm) · P_e = Power consumption · I = Current draw · qv = Air flow · p_{fs} = Pressure increase



Curves: Air performance 60 Hz

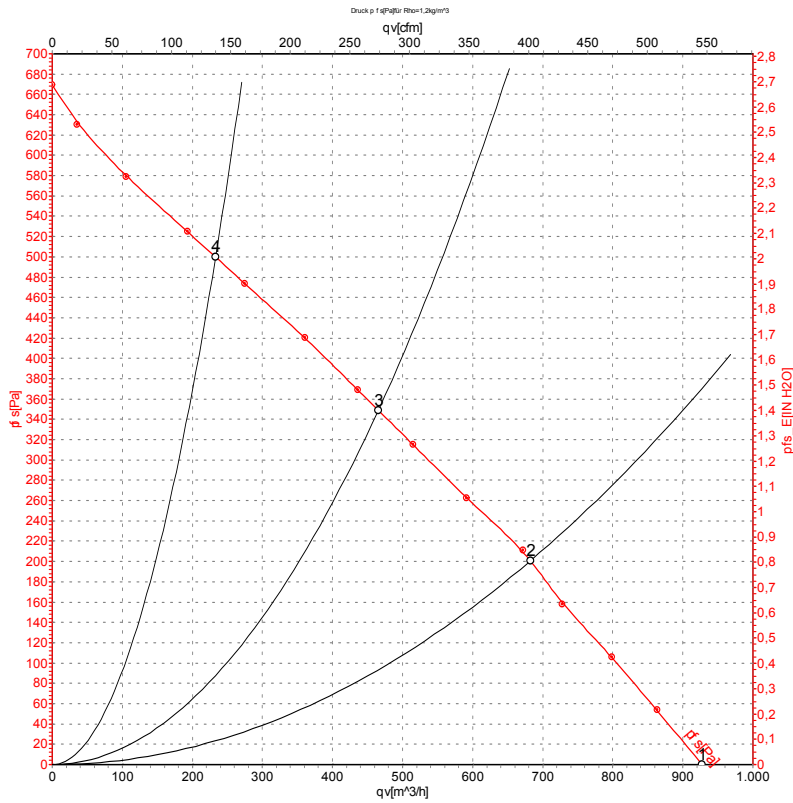

Measurement: LU-57251-1

Air performance measured according to ISO 5801 installation category A. For detailed information on the measurement setup, contact ebm-papst. Intake sound level: Sound power level according to ISO 13347 / sound pressure level measured at 1 m distance from fan axis. The values given are valid under the specified measuring conditions and may vary due to conditions of installation. For deviations from the standard configuration, the parameters have to be checked on the installed unit.

Measured values

	U	f	n	P _e	I	qv	p _{fs}	qv	p _{fs}
	V	Hz	min ⁻¹	W	A	m ³ /h	Pa	CFM	inH ₂ O
1	230	60	2950	145	0.64	925	0	545	0.00
2	230	60	2805	155	0.67	680	200	400	0.80
3	230	60	2790	155	0.67	465	350	275	1.41
4	230	60	2990	138	0.60	235	500	135	2.01

U = Power supply · f = Frequency · n = Speed (rpm) · P_e = Power consumption · I = Current draw · qv = Air flow · p_{fs} = Pressure increase

