

ebm-papst Mulfingen GmbH & Co. KG

Bachmühle 2 · D-74673 Mulfingen

Phone +49 7938 81-0

Fax +49 7938 81-110

sales@fansco.com

www.fansco.com

Limited partnership · Headquarters Mulfingen

Amtsgericht (court of registration) Stuttgart · HRA 590344

General partner Elektrobau Mulfingen GmbH · Headquarters Mulfingen

Amtsgericht (court of registration) Stuttgart · HRB 590142

Nominal data

Type	R2E225-AG03-11	
Motor	M2E068-EC	
Phase		1~
Nominal voltage	VAC	240
Frequency	Hz	50
Method of obtaining data		fa
Valid for approval/standard		CE
Speed (rpm)	min ⁻¹	2600
Power consumption	W	195
Current draw	A	0.82
Capacitor	µF	5
Capacitor voltage	VDB	400
Min. back pressure	Pa	0
Min. back pressure	inH ₂ O	0
Min. ambient temperature	°C	-25
Max. ambient temperature	°C	80

ml = Max. load · me = Max. efficiency · fa = Free air · cs = Customer specification · ce = Customer equipment
Subject to change



Technical description

Weight	4 kg
Fan size	225 mm
Rotor surface	Unpainted
Motor suspension	Motor mounted with brackets on one side
Direction of rotation	Clockwise, viewed toward rotor
Degree of protection	IP20
Insulation class	"F"
Moisture (F) / Environmental (H) protection class	H0 - dry environment
Max. permitted ambient temp. for motor (transport/storage)	+ 80 °C
Min. permitted ambient temp. for motor (transport/storage)	- 40 °C
Installation position	Shaft horizontal
Condensation drainage holes	None
Mode	S1
Motor bearing	Ball bearing
Touch current according to IEC 60990 (measuring circuit Fig. 4, TN system)	< 0.75 mA
Electrical hookup	Via terminal strip
Motor protection	Thermal overload protector (TOP) internally connected
With cable	Axial
Protection class	I (if protective earth is connected by customer to the housing's connection point)
Conformity with standards	CE
Approval	BEAB

Product drawing

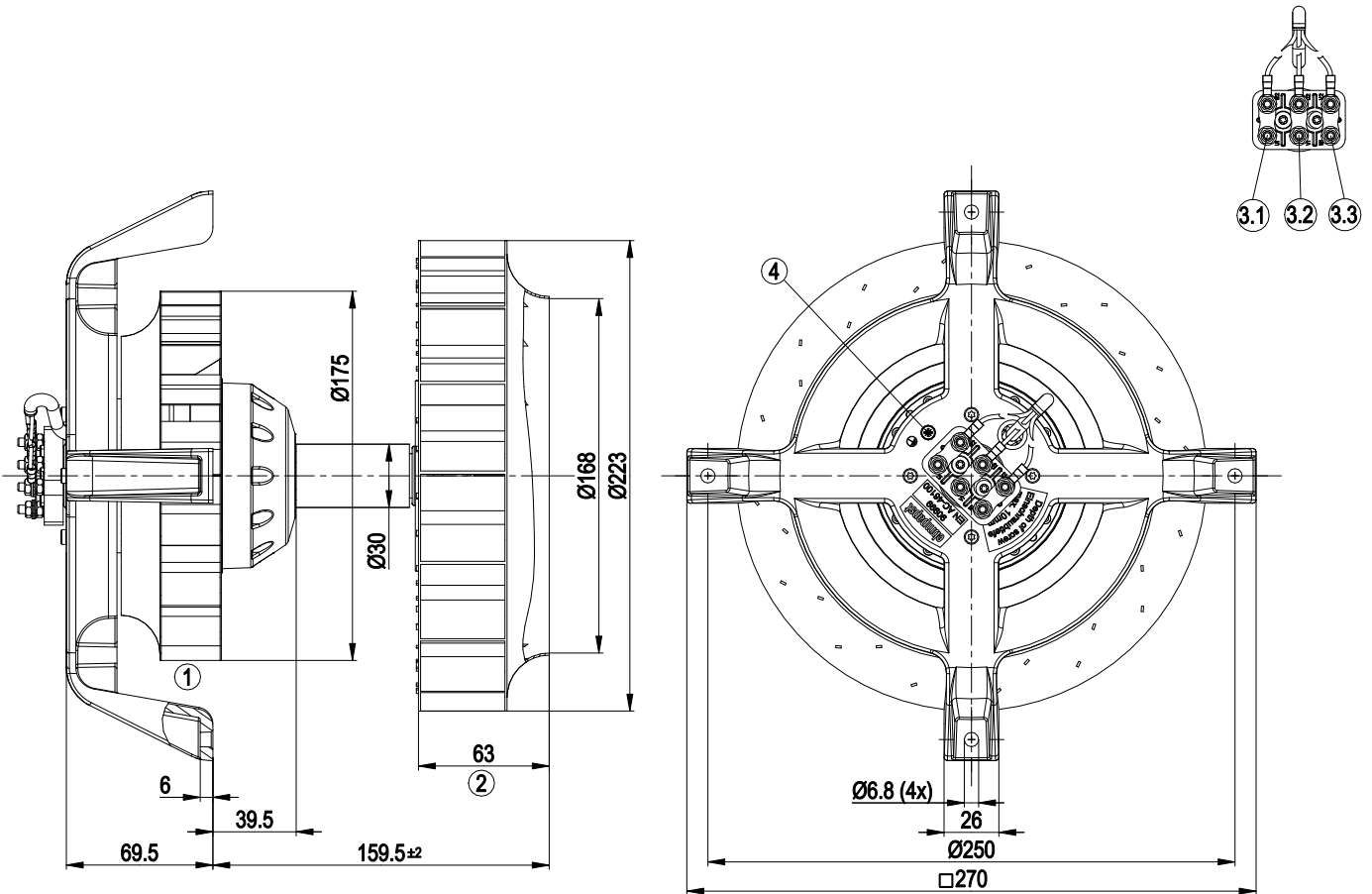

1	Centrifugal fan impeller (sheet steel, galvanized)
2	Centrifugal fan impeller (sheet steel, rust- and acid-resistant)
3.1	L (blue)
3.2	N (black)
3.3	Z (brown)
4	M4 screw for fastening ground connector
	Max. clearance for screw 5 mm



Connection diagram

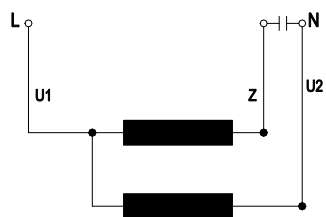

U1	blue	U2	black	Z	brown
----	------	----	-------	---	-------



Curves: Air performance 50 Hz

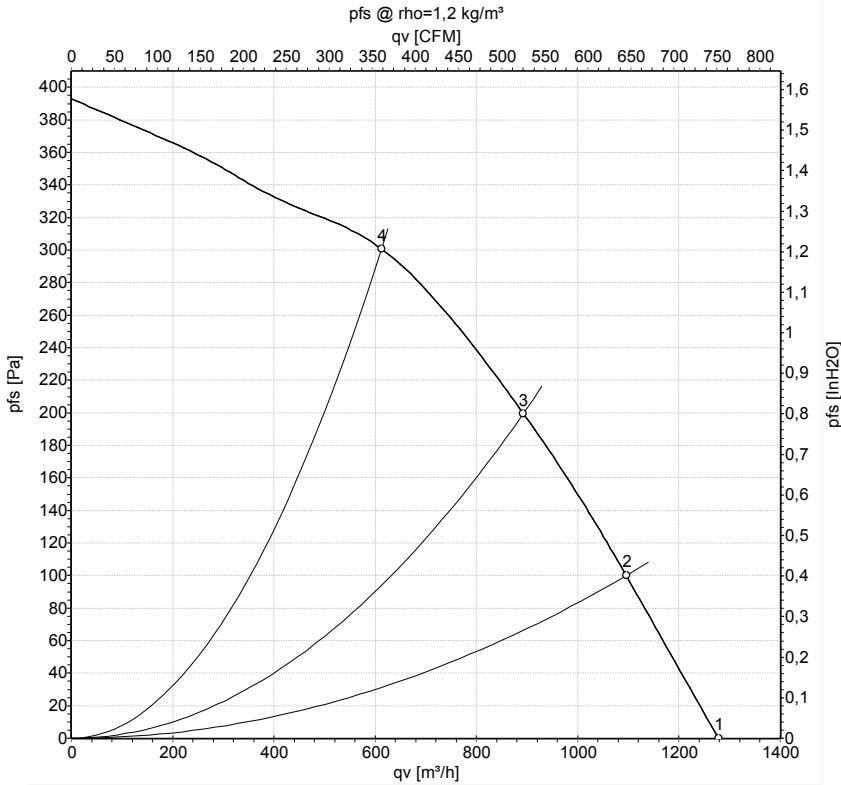

Measurement: LU-4245-1

Air performance measured according to ISO 5801 installation category A. For detailed information on the measurement setup, contact ebm-papst. Intake sound level: Sound power level according to ISO 13347 / sound pressure level measured at 1 m distance from fan axis. The values given are valid under the specified measuring conditions and may vary due to conditions of installation. For deviations from the standard configuration, the parameters have to be checked on the installed unit.

Measured values

	U	f	n	P _e	I	qv	p _{fs}	qv	p _{fs}
	V	Hz	min ⁻¹	W	A	m ³ /h	Pa	CFM	inH2O
1	240	50	2600	195	0.82	1280	0	750	0.00
2	240	50	2560	210	0.87	1095	100	645	0.40
3	240	50	2525	217	0.90	890	200	525	0.80
4	240	50	2550	210	0.88	610	300	360	1.20

U = Power supply · f = Frequency · n = Speed (rpm) · P_e = Power consumption · I = Current draw · qv = Air flow · p_{fs} = Pressure increase

