

ebm-papst Mulfingen GmbH & Co. KG

Bachmühle 2 · D-74673 Mulfingen

Phone +49 7938 81-0

Fax +49 7938 81-110

sales@fansco.com

www.fansco.com

Limited partnership · Headquarters Mulfingen

Amtsgericht (court of registration) Stuttgart · HRA 590344

General partner Elektrobau Mulfingen GmbH · Headquarters Mulfingen

Amtsgericht (court of registration) Stuttgart · HRB 590142

Nominal data

Type	R2E220-AA44-97	
Motor	M2E068-BF	
Phase		1~
Nominal voltage	VAC	115
Frequency	Hz	60
Method of obtaining data		fa
Valid for approval/standard		CE
Speed (rpm)	min ⁻¹	2700
Power consumption	W	100
Current draw	A	0.88
Capacitor	µF	10
Capacitor voltage	VDB	220
Min. back pressure	Pa	0
Min. back pressure	inH ₂ O	0
Min. ambient temperature	°C	-25
Max. ambient temperature	°C	30
Starting current	A	1.05

ml = Max. load · me = Max. efficiency · fa = Free air · cs = Customer specification · ce = Customer equipment
Subject to change



Technical description

Weight	1.4 kg
Fan size	220 mm
Rotor surface	Unpainted
Impeller material	PA6 plastic, glass-fiber reinforced
Number of blades	11
Direction of rotation	Clockwise, viewed toward rotor
Degree of protection	IP44
Insulation class	"B"
Moisture (F) / Environmental (H) protection class	H0 - dry environment
Max. permitted ambient temp. for motor (transport/storage)	+ 80 °C
Min. permitted ambient temp. for motor (transport/storage)	- 40 °C
Installation position	Shaft horizontal
Condensation drainage holes	None
Mode	S1
Motor bearing	Ball bearing
Touch current according to IEC 60990 (measuring circuit Fig. 4, TN system)	< 0.75 mA
Motor protection	Thermal overload protector (TOP) internally connected
With cable	Variable
Protection class	I (with customer connection of protective earth)
Conformity with standards	EN 60335-1; CE
Approval	CSA C22.2 No. 113; UL 507

Product drawing

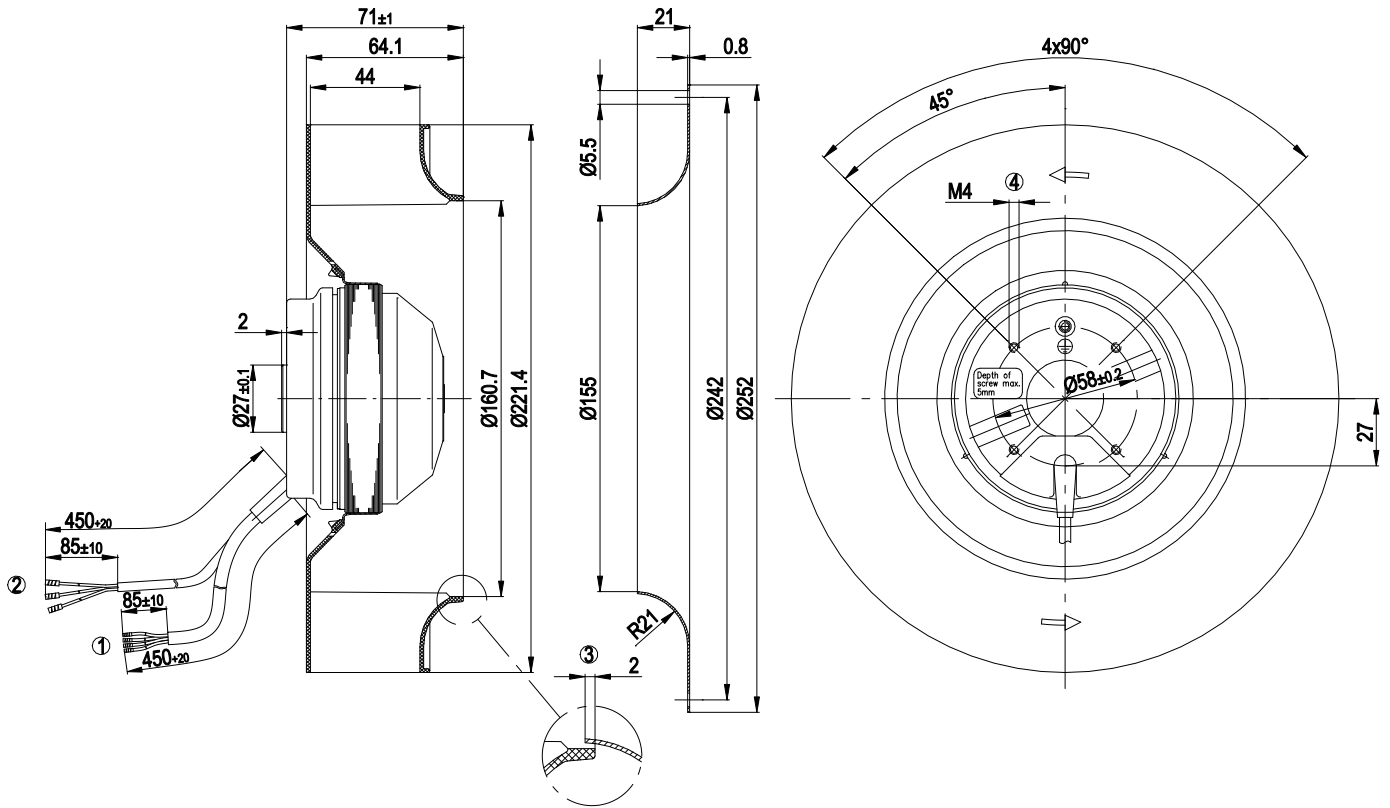

1	Cable PVC, 4x crimped splices
2	Cable, 3x crimped splices
3	Accessory part: inlet ring 09609-2-4013, not included in scope of delivery
4	Max. clearance for screw 5 mm



Connection diagram

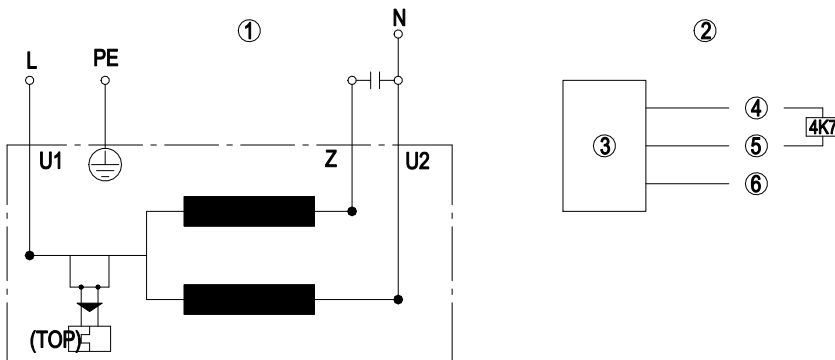

1	Fan connection diagram
TOP	Thermal overload protector
U1	blue
Z	brown
U2	black
PE	green/yellow
2	Hall IC circuit
3	fan
4	red (+5 V)
5	white (out)
6	black (0 V)

Curves: Air performance 60 Hz

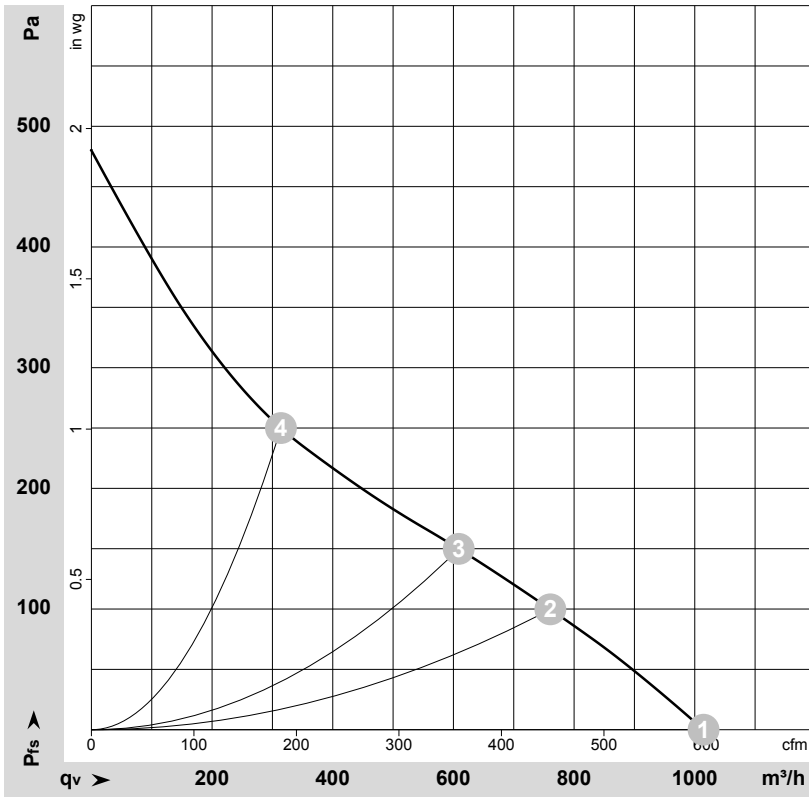

$\rho = 1.15 \text{ kg/m}^3 \pm 2 \%$

Measurement: LU-65497-1

Air performance measured according to ISO 5801 installation category A. For detailed information on the measurement setup, contact ebmpapst. Intake sound level: Sound power level according to ISO 13347 / sound pressure level measured at 1 m distance from fan axis. The values given are valid under the specified measuring conditions and may vary due to conditions of installation. For deviations from the standard configuration, the parameters have to be checked on the installed unit.

Measured values

	U	f	n	P _e	I	qv	p _{fs}	qv	p _{fs}
	V	Hz	min ⁻¹	W	A	m ³ /h	Pa	CFM	inH ₂ O
1	115	60	2750	100	0.88	1015	0	595	0.00
2	115	60	2445	110	0.96	760	100	450	0.40
3	115	60	2275	113	0.99	610	150	360	0.60
4	115	60	2270	112	0.97	315	250	185	1.00

U = Power supply · f = Frequency · n = Speed (rpm) · P_e = Power consumption · I = Current draw · qv = Air flow · p_{fs} = Pressure increase

