

for solid fuel heating systems

**ebm-papst Mulfingen GmbH & Co. KG**

Bachmühle 2 · D-74673 Mulfingen

Phone +49 7938 81-0

Fax +49 7938 81-110

sales@fansco.com

www.fansco.com

Limited partnership · Headquarters Mulfingen

County court Stuttgart · HRA 590344

General partner Elektrobau Mulfingen GmbH · Headquarters Mulfingen

County court Stuttgart · HRB 590142

**Nominal data**

<b>Type</b>	<b>R2E210-AB34-05</b>	
<b>Motor</b>	<b>M2E068-DF</b>	
Phase		1~
Nominal voltage	VAC	230
Frequency	Hz	50
Type of data definition		fa
Valid for approval / standard		CE
Speed	min <sup>-1</sup>	2400
Power input	W	125
Current draw	A	0.56
Motor capacitor	µF	2.5
Capacitor voltage	VDB	400
Capacitor standard		P0 (CE)
Min. back pressure	Pa	0
Min. ambient temperature	°C	-25
Max. ambient temperature	°C	45

ml = Max. load · me = Max. efficiency · fa = Running at free air · cs = Customer specs · cu = Customer unit  
Subject to alterations



### Technical features

<b>Mass</b>	3.5 kg
<b>Size</b>	210 mm
<b>Surface of rotor</b>	Partially cast in aluminium
<b>Material of impeller</b>	Sheet steel, stainless
<b>Material of mounting plate</b>	Sheet steel, hot-galvanised
<b>Number of blades</b>	6
<b>Motor suspension</b>	Motor anti-vibration mounted on one side via mounting plate
<b>Direction of rotation</b>	Counter-clockwise, seen on rotor
<b>Type of protection</b>	IP 44; Depending on installation and position
<b>Insulation class</b>	"F"
<b>Humidity class</b>	F0
<b>Max. permissible ambient motor temp. (transp./ storage)</b>	+ 80 °C
<b>Min. permissible ambient motor temp. (transp./storage)</b>	- 40 °C
<b>Mounting position</b>	Any
<b>Condensate discharge holes</b>	None
<b>Operation mode</b>	S1
<b>Motor bearing</b>	Ball bearing
<b>Touch current acc. IEC 60990 (measuring network Fig. 4, TN system)</b>	< 0.75 mA
<b>Motor protection</b>	Thermal overload protector (TOP) wired internally
<b>Cable exit</b>	Variable
<b>Protection class</b>	I (if protective earth is connected by customer)
<b>Product conforming to standard</b>	EN 60335-1; CE
<b>Approval</b>	EAC

Product drawing

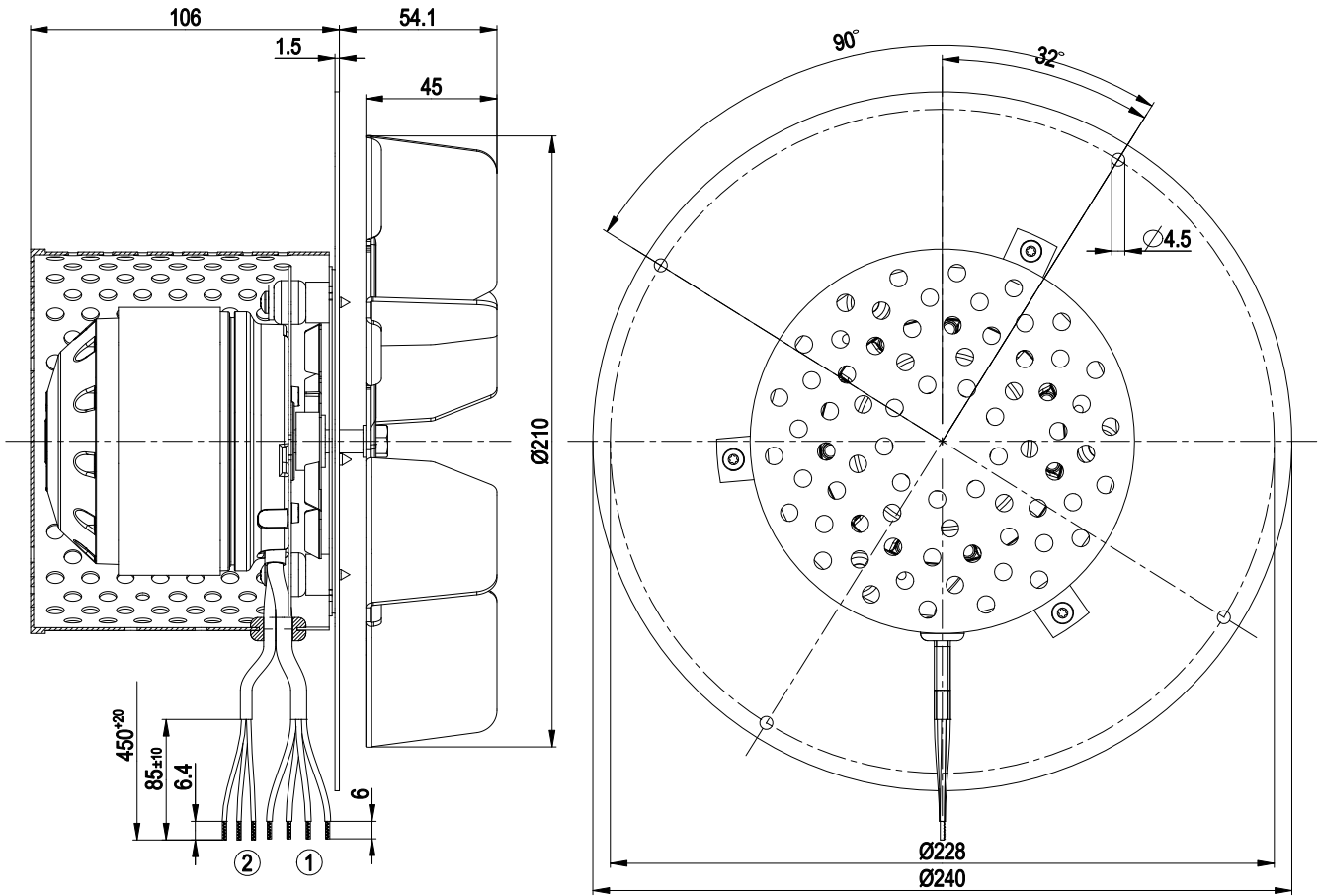

- |   |   |
|---|---|
| 1 | Connection line silicone 4G 0.5 mm <sup>2</sup> , 4 x brass lead tips crimped |
| 2 | Connection line Raychem AWG24, 3x brass lead tips crimped                     |

## Connection screen

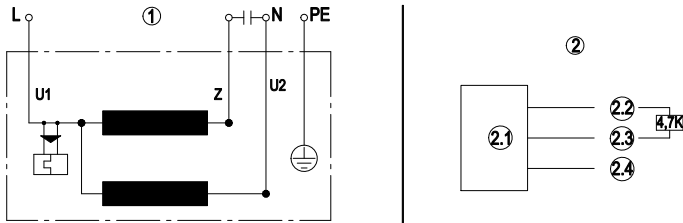

1	Fan connection diagram
---	------------------------

U1	Blue
----	------

Z	brown
---	-------

U2	black
----	-------

PE	green/yellow
----	--------------

2	Hall IC circuit
---	-----------------

2.1	Hall IC
-----	---------

2.2	Red (+5V)
-----	-----------

2.3	White (out)
-----	-------------

2.4	Black (0V)
-----	------------

## Charts: Air flow 50 Hz

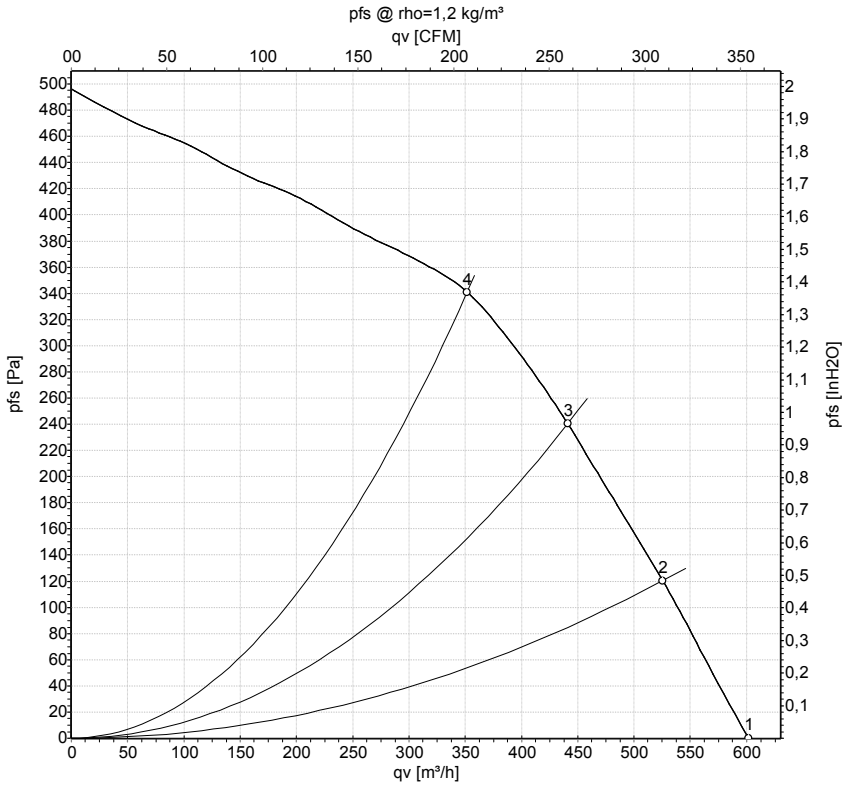

Measurement: LU-138690

Air performance measured as per ISO 5801 Installation category A. For detailed information on the measuring set-up, please contact ebm-papst. Suction-side noise levels: L<sub>wA</sub> measured as per ISO 13347 / L<sub>pA</sub> measured with 1m distance to fan axis. The values given are valid under the measuring conditions mentioned above and may vary according to the actual installation situation. With any deviation from the standard set-up, the specific values have to be checked and reviewed with the unit installed.

## Measured values

	U	f	n	P <sub>e</sub>	I	qv	p <sub>fs</sub>
	V	Hz	min <sup>-1</sup>	W	A	m <sup>3</sup> /h	Pa
1	230	50	2400	125	0.56	600	0
2	230	50	2420	125	0.54	525	120
3	230	50	2455	122	0.53	440	240
4	230	50	2545	111	0.48	350	340

U = Supply voltage · f = Frequency · n = Speed · P<sub>e</sub> = Power input · I = Current draw · qv = Air flow · p<sub>fs</sub> = Pressure increase

