

R2E140-AI31-30

# AC centrifugal fan

forward-curved, single-intake



## ebm-papst Mulfingen GmbH & Co. KG

Bachmühle 2 · D-74673 Mulfingen

Phone +49 7938 81-0

Fax +49 7938 81-110

sales@fansco.com

www.fansco.com

Limited partnership · Headquarters Mulfingen

Amtsgericht (court of registration) Stuttgart · HRA 590344

General partner Elektrobau Mulfingen GmbH · Headquarters Mulfingen

Amtsgericht (court of registration) Stuttgart · HRB 590142

## Nominal data

Type	R2E140-AI31-30		
Motor	M2E068-DF		
Phase		1~	1~
Nominal voltage	VAC	115	115
Frequency	Hz	60	60
Method of obtaining data		fa	fa
Valid for approval/standard		CE	UL 2111
Speed (rpm)	min <sup>-1</sup>	2200	2200
Power consumption	W	180	195
Current draw	A	1.58	1.64
Capacitor	µF	12	12
Capacitor voltage	VDB	250	250
Capacitor standard		S2 (CE)	
Min. back pressure	Pa	0	0
Min. back pressure	inH <sub>2</sub> O	0	0
Max. ambient temperature	°C	70	70
Starting current	A	2.1	2.1

ml = Max. load · me = Max. efficiency · fa = Free air · cs = Customer specification · ce = Customer equipment  
Subject to change



### Technical description

<b>Weight</b>	2.1 kg
<b>Fan size</b>	140 mm
<b>Rotor surface</b>	Painted black
<b>Impeller material</b>	Sheet steel, painted black
<b>Direction of rotation</b>	Clockwise, viewed toward rotor
<b>Degree of protection</b>	IP44
<b>Insulation class</b>	"B"
<b>Moisture (F) / Environmental (H) protection class</b>	H0+
<b>Max. permitted ambient temp. for motor (transport/storage)</b>	+ 80 °C
<b>Min. permitted ambient temp. for motor (transport/storage)</b>	- 40 °C
<b>Installation position</b>	Shaft horizontal or rotor on bottom; rotor on top on request
<b>Condensation drainage holes</b>	On rotor side
<b>Mode</b>	S1
<b>Motor bearing</b>	Ball bearing
<b>Touch current according to IEC 60990 (measuring circuit Fig. 4, TN system)</b>	< 0.75 mA
<b>Motor protection</b>	Thermal overload protector (TOP) internally connected
<b>With cable</b>	Variable
<b>Protection class</b>	I (with customer connection of protective earth)
<b>Conformity with standards</b>	EN 60335-1; CE
<b>Approval</b>	UL 2111; CSA C22.2 No. 77

## Product drawing

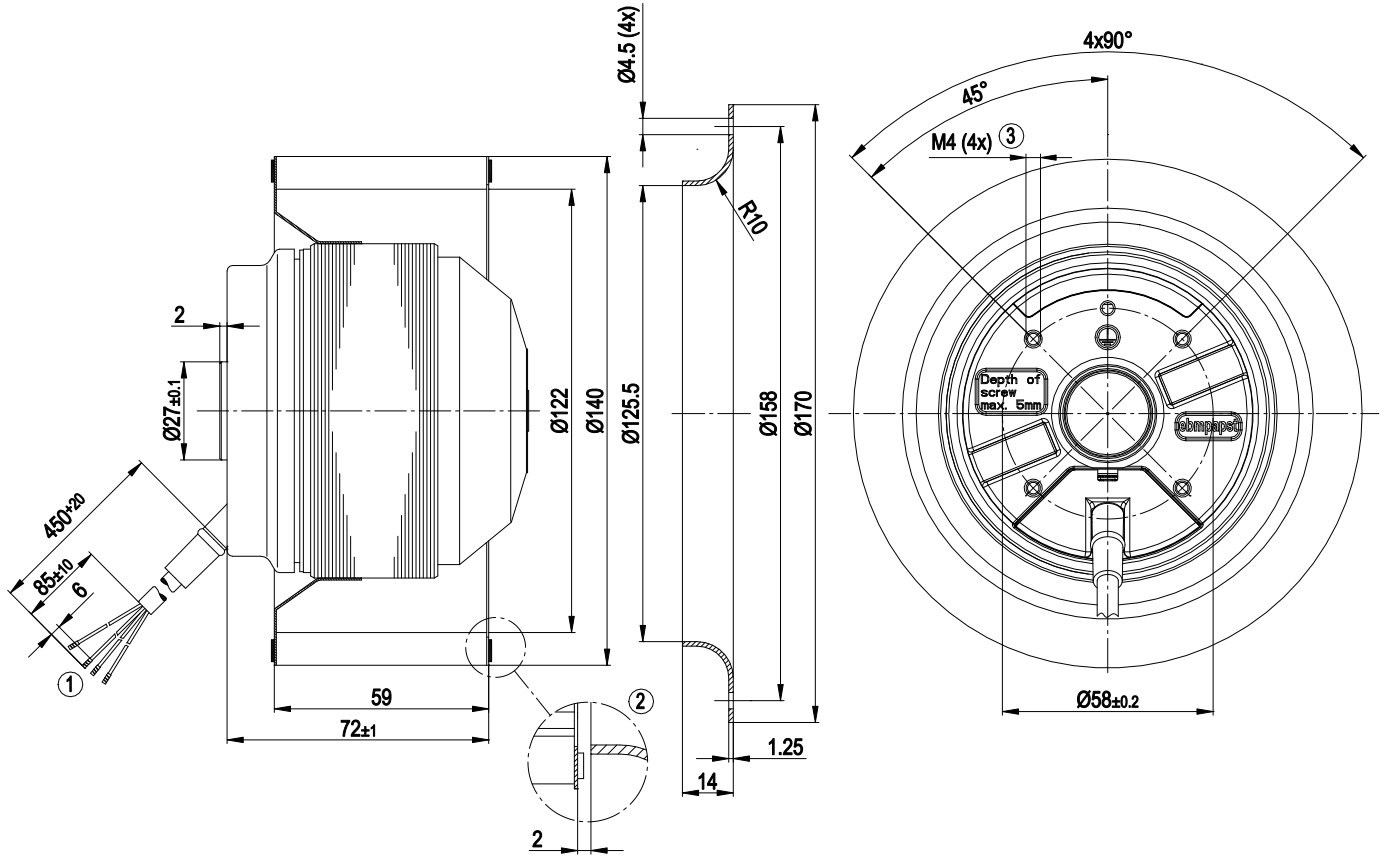

1	Cable PVC 4G AWG20, 4x crimped splices
2	Accessory part: inlet ring 09576-2-4013, not included in scope of delivery
3	Max. clearance for screw 5 mm

## Connection diagram

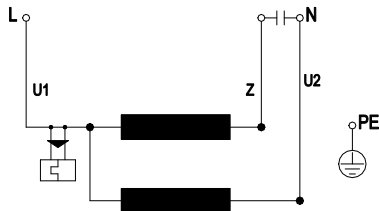

U1	blue	Z	brown	U2	black
PE	green/yellow				

## Curves: Air performance 60 Hz

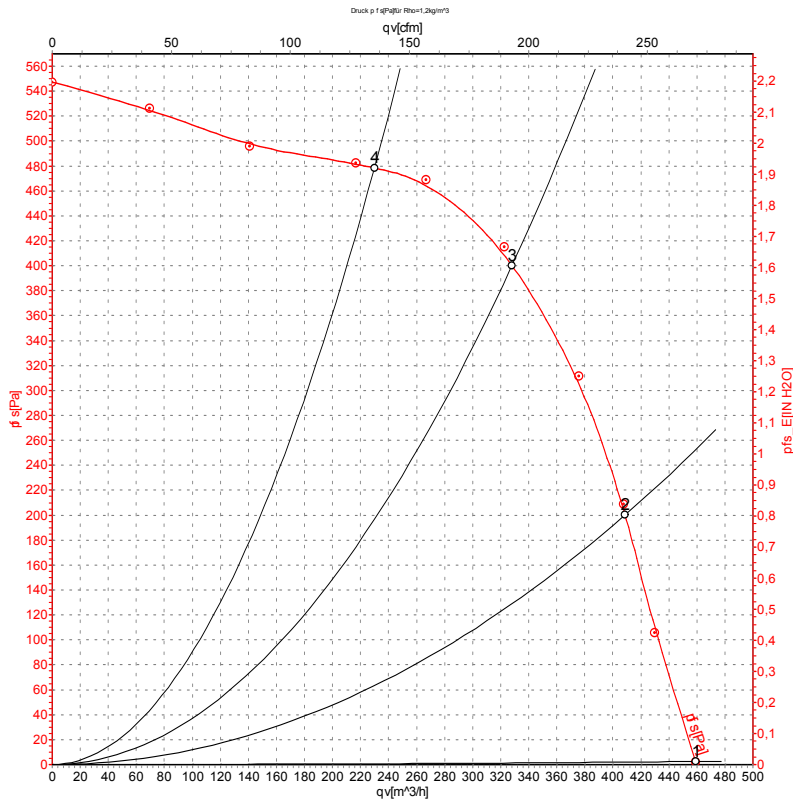

Measurement: LU-61879-1

Air performance measured according to ISO 5801 installation category A. For detailed information on the measurement setup, contact ebm-papst. Intake sound level: Sound power level according to ISO 13347 / sound pressure level measured at 1 m distance from fan axis. The values given are valid under the specified measuring conditions and may vary due to conditions of installation. For deviations from the standard configuration, the parameters have to be checked on the installed unit.

## Measured values

	U	f	n	P <sub>e</sub>	I	q <sub>v</sub>	p <sub>fs</sub>	q <sub>v</sub>	p <sub>fs</sub>
	V	Hz	min <sup>-1</sup>	W	A	m³/h	Pa	cfm	inH <sub>2</sub> O
1	115	60	2200	180	1.58	460	0	270	0.00
2	115	60	2470	169	1.46	410	200	240	0.80
3	115	60	2805	151	1.31	330	400	195	1.61
4	115	60	3060	131	1.15	230	480	135	1.93

U = Power supply · f = Frequency · n = Speed (rpm) · P<sub>e</sub> = Power consumption · I = Current draw · q<sub>v</sub> = Air flow · p<sub>fs</sub> = Pressure increase

