

EC centrifugal module - RadiPac

backward curved, single inlet

in cube design

ebm-papst Mulfingen GmbH & Co. KG

Bachmühle 2 · D-74673 Mulfingen

Phone +49 7938 81-0

Fax +49 7938 81-110

sales@fansco.com

www.fansco.com

Limited partnership · Headquarters Mulfingen

County court Stuttgart · HRA 590344

General partner Elektrobau Mulfingen GmbH · Headquarters Mulfingen

County court Stuttgart · HRB 590142



Nominal data

Type	K3G710-AR03-01	
Motor	M3G200-LA	
Phase		3~
Nominal voltage	VAC	400
Nominal voltage range	VAC	380 .. 480
Frequency	Hz	50/60
Type of data definition		ml
State		prelim.
Speed	min ⁻¹	1300
Power input	W	7860
Current draw	A	12.0
Min. ambient temperature	°C	-40
Max. ambient temperature	°C	40

ml = Max. load · me = Max. efficiency · fa = Running at free air · cs = Customer specs · cu = Customer unit
Subject to alterations

Data according to ErP directive

Installation category	A
Efficiency category	Static
Variable speed drive	Yes
Specific ratio*	1.01

* Specific ratio = $1 + p_{fs} / 100\,000\text{ Pa}$

	Actual	Request 2013	Request 2015
Overall efficiency η_{es}	64.3	56.9	60.9
Efficiency grade N	65.4	58	62
Power input P_{ed}	kW	7.86	
Air flow q_v	m ³ /h	19025	
Pressure increase p_{fs}	Pa	920	
Speed n	min ⁻¹	1300	

Data definition with optimum efficiency.



Technical features

Mass	163 kg
Size	710 mm
Surface of rotor	Coated in black
Material of electronics housing	Die-cast aluminium
Material of impeller	Aluminium sheet
Material of inlet nozzle	Sheet steel, galvanised and plastic-coated in light grey (RAL 7035)
Material of support structure	Sheet steel, galvanised and plastic-coated in light grey (RAL 7035)
Number of blades	7
Direction of rotation	Clockwise, seen on rotor
Type of protection	IP 54
Insulation class	"F"
Humidity class	F4-1
Max. permissible ambient motor temp. (transp./ storage)	+80 °C
Min. permissible ambient motor temp. (transp./storage)	-40 °C
Mounting position	Shaft horizontal (only base mounting) or rotor on bottom; rotor on top on request
Condensate discharge holes	Rotor-side
Operation mode	S1
Motor bearing	Ball bearing
Technical features	<ul style="list-style-type: none"> - Output 10 VDC, max. 10 mA - Output 20 VDC, max. 50 mA - Output for slave 0-10 V - Operation and alarm display - Input for sensor 0-10 V or 4-20 mA - External 24 V input (programming) - External release input - Alarm relay - Integrated PID controller - Motor current limit - PFC, passive - RS485 MODBUS RTU - Soft start - Control input 0-10 VDC / PWM - Control interface with SELV potential safely disconnected from the mains - Over-temperature protected electronics / motor - Line undervoltage / phase failure detection
Touch current acc. IEC 60990 (measuring network Fig. 4, TN system)	<= 3.5 mA
Electrical leads	Via terminal box
Motor protection	Reverse polarity and locked-rotor protection
Protection class	I (if protective earth is connected by customer)
Product conforming to standard	EN 61800-5-1; CE
Approval	GOST

EC centrifugal module - RadiPac

backward curved, single inlet
in cube design

Product drawing

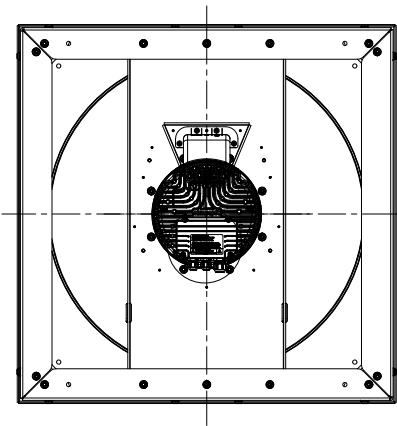
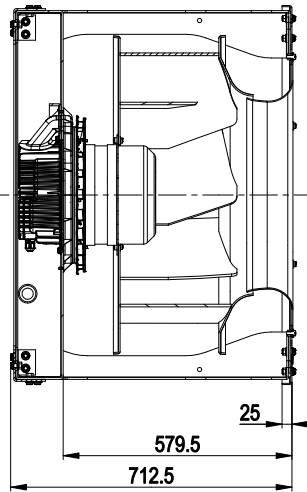
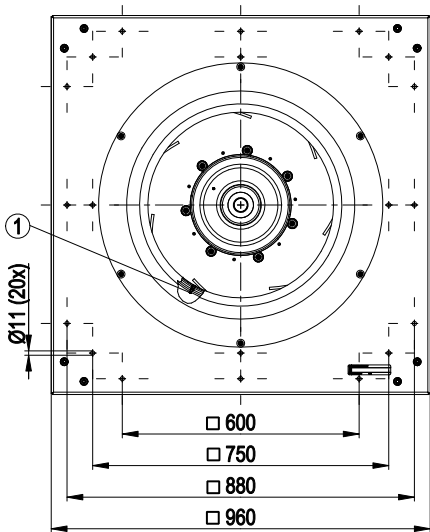
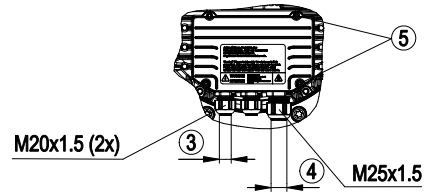
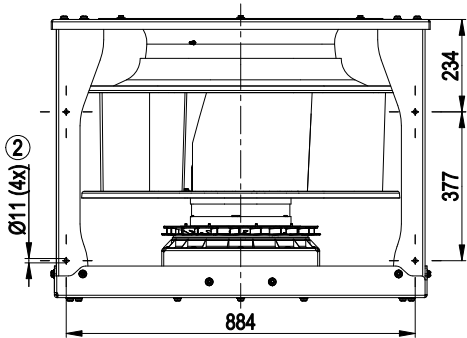

- | | |
|---|--|
| 1 | Inlet nozzle with bleeder connection for pressure relief (k-factor: 545) |
| 2 | Screw-on position for vibration-absorbing elements |
| 3 | Cable diameter: min. 4 mm, max. 10 mm, tightening torque: 4±0.6 Nm |
| 4 | Cable diameter: min. 9 mm, max. 16 mm, tightening torque: 6±0.9 Nm |
| 5 | Tightening torque 3.5±0.5 Nm |



EC centrifugal module - RadiPac

backward curved, single inlet

in cube design

Connection screen

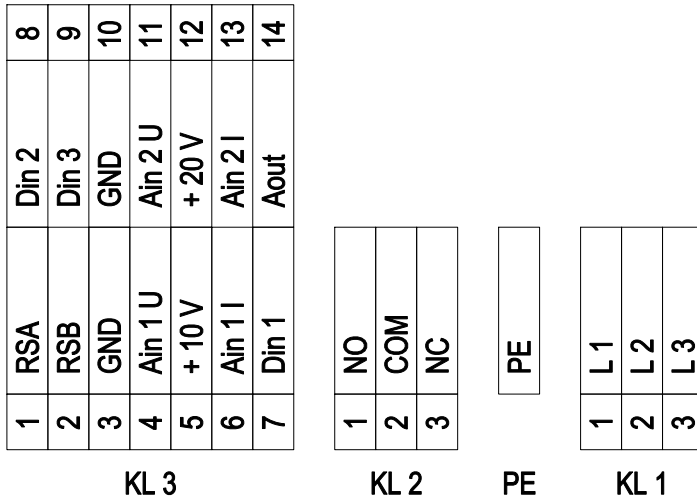

No.	Pin	Signal	Function / assignment
KL 1	1	L1	Mains supply connection, supply voltage 3~380-480 VAC; 50/60 Hz
KL 1	2	L2	Mains supply connection, supply voltage 3~380-480 VAC; 50/60 Hz
KL 1	3	L3	Mains supply connection, supply voltage 3~380-480 VAC; 50/60 Hz
PE		PE	Earth connection, PE connection
KL 2	1	NO	Status relay, floating status contact; normally open; close with error
KL2	2	COM	Status relay; floating status contact; changeover contact; common connection; contact rating 250 VAC / 2 A (AC1)
KL2	3	NC	Status relay, floating status contact; break with error
KL 3	1	RSA	Bus connection RS485; RSA; MODBUS RTU
KL 3	2	RSB	Bus connection RS485; RSB; MODBUS RTU
KL 3	3 / 10	GND	Signal ground for control interface KL3
KL 3	4	Ain1 U	Analogue input 1 (set value); 0-10 V; Ri= 100 kΩ; parametrisable curves; only usable as alternative to input Ain1 I
KL 3	5	+ 10 V	Fixed voltage output 10 VDC; + 10 V +/-3%; max. 10 mA; short circuit proof; power supply for ext. devices (e.g. potentiometer)
KL 3	6	Ain1 I	Analogue input 1 (set value); 4-20 mA; Ri= 100 Ω; parametrisable curves; only usable as alternative to input Ain1 U
KL 3	7	Din1	Digital input 1: enabling of electronics; enabling: open pin or applied voltage 5 to 50 VDC; disabling: bridge to GND or applied voltage < 1 VDC; reset function: triggers software reset after a level change to <1 V
KL 3	8	Din2	Digital input 2: parameter set switch 1/2; according to EEPROM setting, the valid/used parameter set is selectable per BUS or per digital input DIN2. Parameter set 1: open pin or applied voltage 5 to 50 VDC; parameter set 2: bridge to GND or applied voltage < 1 VDC
KL 3	9	Din3	Digital input 3: Control characteristic of the integrated controller; according to EEPROM setting, the control characteristic of the integrated controller is normally/inversely selectable per BUS or per digital input; normal: open pin or applied voltage 5 to 50 VDC (control deviation = actual sensor value - set value) inverse: bridge to GND or applied voltage < 1 VDC (control deviation = set value - actual sensor value)
KL 3	11	Ain2 U	Analogue input 2; actual sensor value 0-10 V; Ri= 100 kΩ; parametrisable curve; only usable as alternative to input Ain2 I
KL 3	12	+ 20 V	Fixed voltage output 20 VDC; + 20 V +25/-10 %; max. 50 mA; short circuit proof; power supply for ext. devices (e.g. sensors)
KL 3	13	Ain2 I	Analogue input 2; actual sensor value 4-20 mA; Ri= 100 Ω; parametrisable curve; only usable as alternative to input Ain2 U
KL 3	14	Aout	Analogue output 0-10 V; max. 5 mA; output of the actual motor control factor (output voltage of electronics)/ of the actual motor speed; function selectable per bus; parametrisable curve.



Charts: Air flow 50 Hz

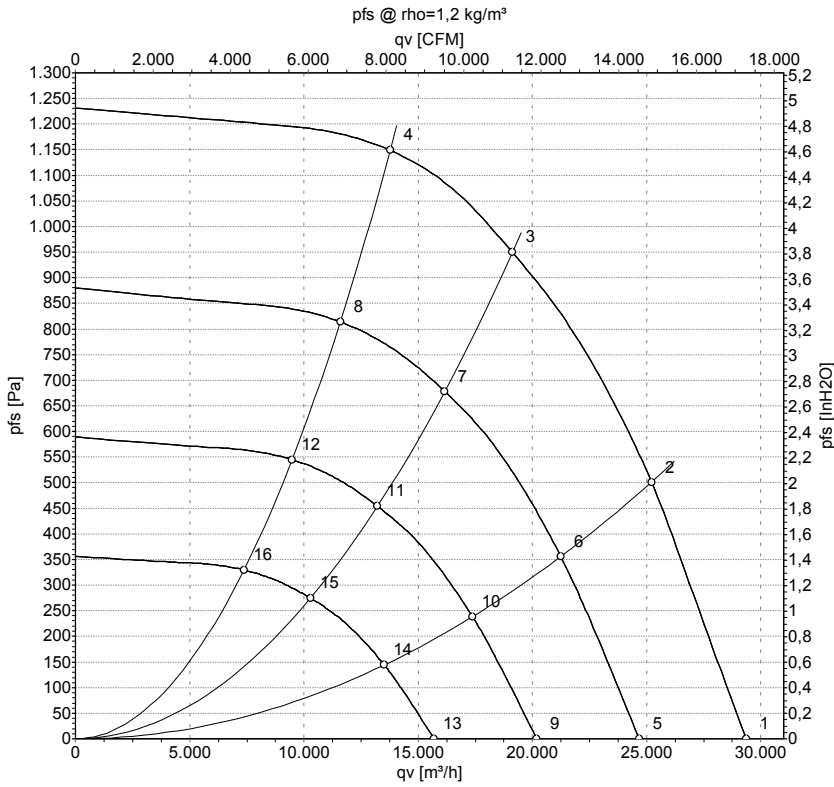

Measurement: LU-149643

Air performance measured as per ISO 5801 Installation category A. For detailed information on the measuring set-up, please contact ebmpapst. Suction-side noise levels: LwA measured as per ISO 13347 / LpA measured with 1m distance to fan axis. The values given are valid under the measuring conditions mentioned above and may vary according to the actual installation situation. With any deviation from the standard set-up, the specific values have to be checked and reviewed with the unit installed.

Measured values

	U	f	n	P _{ed}	I	LpA _{in}	LwA _{in}	LwA _{out}	qv	p _{fs}
	V	Hz	min ⁻¹	W	A	dB(A)	dB(A)	dB(A)	m ³ /h	Pa
1	400	50	1300	5116	7.87	87	96	101	29355	0
2	400	50	1300	6911	10.63	83	91	95	25215	500
3	400	50	1300	7860	12.00	79	86	91	19130	950
4	400	50	1300	7367	11.21	81	87	92	13775	1150
5	400	50	1100	3036	4.67	83	92	97	24665	0
6	400	50	1100	4120	6.34	79	86	91	21245	360
7	400	50	1100	4748	7.24	75	82	87	16165	681
8	400	50	1100	4393	6.68	76	83	87	11595	814
9	400	50	900	1663	2.56	78	87	91	20180	0
10	400	50	900	2256	3.47	73	81	86	17385	241
11	400	50	900	2600	3.96	70	77	81	13225	456
12	400	50	900	2406	3.66	71	78	82	9485	545
13	400	50	700	782	1.20	72	81	85	15695	0
14	400	50	700	1062	1.63	67	75	80	13520	146
15	400	50	700	1224	1.87	64	71	75	10285	276
16	400	50	700	1132	1.72	65	72	76	7380	330

U = Supply voltage · f = Frequency · n = Speed · P_{ed} = Power input · I = Current draw · LpA_{in} = Sound pressure level inlet side · LwA_{in} = Sound power level inlet side · LwA_{out} = Sound power level outlet side
 qv = Air flow · p_{fs} = Pressure increase

