

EC centrifugal module - RadiPac

backward curved, single inlet

in cube design

ebm-papst Mulfingen GmbH & Co. KG

Bachmühle 2 · D-74673 Mulfingen

Phone +49 7938 81-0

Fax +49 7938 81-110

sales@fansco.com

www.fansco.com

Limited partnership · Headquarters Mulfingen

County court Stuttgart · HRA 590344

General partner Elektrobau Mulfingen GmbH · Headquarters Mulfingen

County court Stuttgart · HRB 590142

Nominal data

Type	K3G710-AQ04-19	
Motor	M3G200-LA	
Phase		3~
Nominal voltage	VAC	200
Nominal voltage range	VAC	200 .. 240
Frequency	Hz	50/60
Type of data definition		ml
State		prelim.
Speed	min ⁻¹	1180
Power input	W	6050
Current draw	A	18.5
Min. ambient temperature	°C	-25
Max. ambient temperature	°C	40

ml = Max. load · me = Max. efficiency · fa = Running at free air · cs = Customer specs · cu = Customer unit
Subject to alterations



Technical features

Mass	156 kg
Size	710 mm
Surface of rotor	Coated in black
Material of electronics housing	Die-cast aluminium
Material of impeller	Aluminium sheet
Material of inlet nozzle	Sheet steel, galvanised and plastic-coated in light grey (RAL 7035)
Material of support structure	Sheet steel, galvanised and plastic-coated in light grey (RAL 7035)
Number of blades	7
Direction of rotation	Clockwise, seen on rotor
Type of protection	IP 54
Insulation class	"F"
Humidity class	F4-1
Max. permissible ambient motor temp. (transp./ storage)	+80 °C
Min. permissible ambient motor temp. (transp./storage)	-40 °C
Mounting position	Shaft horizontal (base mounting only) or rotor on bottom
Condensate discharge holes	Rotor-side
Operation mode	S1
Motor bearing	Ball bearing
Technical features	<ul style="list-style-type: none"> - Output 10 VDC, max. 10 mA - Output 20 VDC, max. 50 mA - Output for slave 0-10 V - Input for sensor 0-10 V or 4-20 mA - External 24 V input (programming) - External release input - Alarm relay - Integrated PID controller - Motor current limit - PFC, passive - RS485 MODBUS RTU - Soft start - Control input 0-10 VDC / PWM - Control interface with SELV potential safely disconnected from the mains - Over-temperature protected electronics / motor - Line undervoltage / phase failure detection
Touch current acc. IEC 60990 (measuring network Fig. 4, TN system)	<= 3.5 mA
Electrical leads	Via terminal box
Motor protection	Reverse polarity and locked-rotor protection
Protection class	I (if protective earth is connected by customer)
Product conforming to standard	EN 61800-5-1; CE

EC centrifugal module - RadiPac

backward curved, single inlet
in cube design

Product drawing

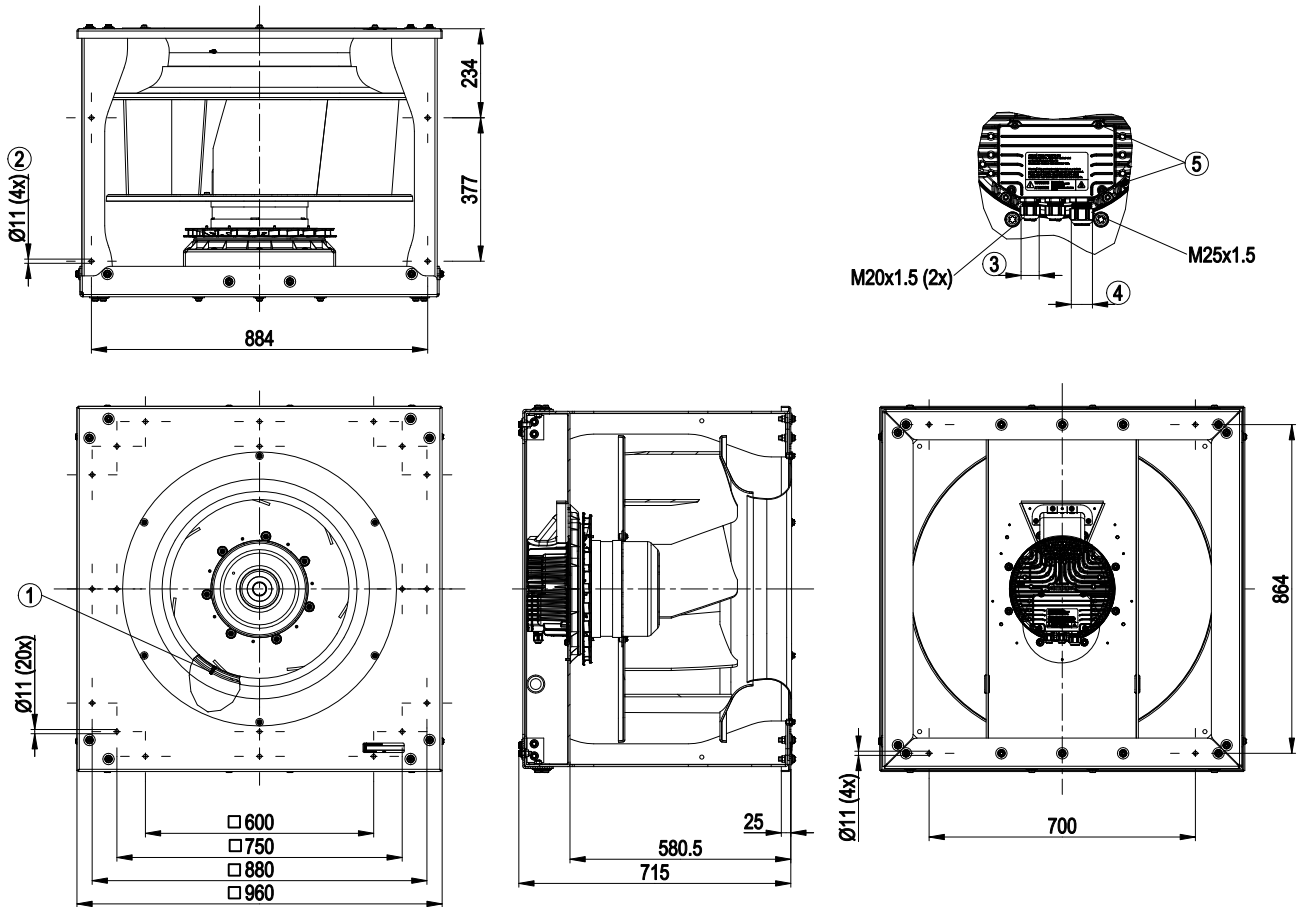

1	Inlet nozzle with pressure tap (k-factor: 545)
2	Screw-on position for vibration-absorbing elements
3	Cable diameter min. 4 mm, max. 10 mm, tightening torque 4 ± 0.6 Nm
4	Cable diameter min. 9 mm, max. 16 mm, tightening torque 6 ± 0.9 Nm
5	Tightening torque 3.5 ± 0.5 Nm

EC centrifugal module - RadiPac

backward curved, single inlet

in cube design

Connection screen

	8	Din 2
	9	Din 3
	10	GND
	11	Ain 2 U
	12	+ 20 V
	13	Ain 2 I
	14	Aout
1	RSA	
2	RSB	
3	GND	
4	Ain 1 U	
5	+ 10 V	
6	Ain 1 I	
7	Din 1	

KL 3

1	NO
2	COM
3	NC

KL 2

PE

PE

1	L1
2	L2
3	L3

KL 1

No.	Conn.	Designation	Function / assignment
KL 1	1	L1	Mains supply connection, supply voltage 3~200-240 VAC; 50/60 Hz
KL 1	2	L2	Mains supply connection, supply voltage 3~200-240 VAC; 50/60 Hz
KL 1	3	L3	Mains supply connection, supply voltage 3~200-240 VAC; 50/60 Hz
PE		PE	Earth connection, PE connection
KL 2	1	NO	Status relay, floating status contact; normally open; close with error
KL2	2	COM	Status relay; floating status contact; changeover contact; common connection; contact rating 250 VAC / max. 2 A (AC1) / min. 10 mA
KL2	3	NC	Status relay, floating status contact; break with error
KL 3	1	RSA	Bus connection RS-485, RSB, MODBUS RTU; SELV
KL 3	2	RSB	Bus connection RS-485, RSA, MODBUS RTU; SELV
KL 3	3 / 10	GND	Signal ground for control interface; SELV
KL 3	4	Ain1 U	Analogue input 1, set value: 0-10 V, Ri = 100 kΩ, parametrisable curve, only usable as alternative to input Ain1; SELV
KL 3	5	+ 10 V	Fixed voltage output 10 VDC, +10 V ±3%, max. 10 mA, short-circuit-proof, power supply for external devices (e.g. potentiometer), SELV
KL 3	6	Ain1 I	Analogue input 1, set value: 4-20 mA; Ri = 100 Ω, parametrisable curve, only usable as alternative to input Ain1 U; SELV
KL 3	7	Din1	Digital input 1: enabling of electronics, enabling: open pin or applied voltage 5-50 VDC disabling: bridge to GND or applied voltage <1 VDC reset function: triggers software reset after a level change to <1 VDC; SELV
KL 3	8	Din2	Digital input 2: parameter set switch 1/2, according to EEPROM setting, the valid/used parameter set can be selected via bus or via digital input DIN2. Parameter set 1: open pin or applied voltage 5-50 VDC Parameter set 2: bridge to GND or applied voltage <1 VDC; SELV
KL 3	9	Din3	Digital input 3: controller function of integrated controller, according to EEPROM setting, the controller function of the integrated controller is normally/inversely selectable per bus or per digital input normal: open pin or applied voltage 5-50 VDC inverse: bridge to GND or applied voltage <1 VDC; SELV
KL 3	11	Ain2 U	Analogue input 2, actual value: 0-10 V, Ri = 100 kΩ, parametrisable curve, only usable as alternative to input Ain2; SELV
KL 3	12	+ 20 V	Fixed voltage output 20 VDC, +20 V ±5/-10%, max. 50 mA, short-circuit-proof, power supply for external devices (e.g. sensors); SELV



EC centrifugal module - RadiPac

backward curved, single inlet

in cube design

No.	Conn.	Designation	Function / assignment
KL 3	13	Ain2 I	Analogue input 2, actual value: 4-20 mA, Ri = 100 Ω , parametrisable curve, only usable as alternative to input Ain2 U; SELV
KL 3	14	Aout	Analogue output 0-10 VDC, max. 5 mA, output of the current motor level control coefficient / motor speed parametrisable curve; SELV



Charts: Air flow 50 Hz

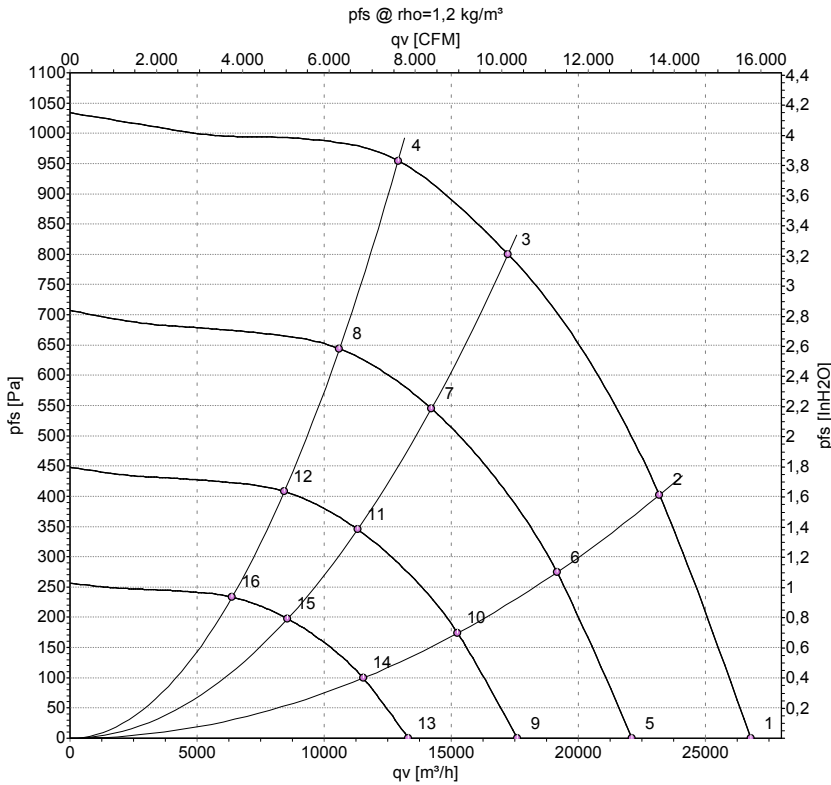

Measurement: LU-159261

Air performance measured as per ISO 5801 Installation category A. For detailed information on the measuring set-up, please contact ebmpapst. Suction-side noise levels: LwA measured as per ISO 13347 / LpA measured with 1m distance to fan axis. The values given are valid under the measuring conditions mentioned above and may vary according to the actual installation situation. With any deviation from the standard set-up, the specific values have to be checked and reviewed with the unit installed.

Measured values

	U	f	n	P _{ed}	I	LpA _{in}	LwA _{in}	LwA _{out}	qv	p _{fs}
	V	Hz	min ⁻¹	W	A	dB(A)	dB(A)	dB(A)	m ³ /h	Pa
1	200	50	1180	3829	11.69	84	93	97	26800	0
2	200	50	1180	5172	15.84	79	88	92	23200	400
3	200	50	1180	6050	18.50	75	83	88	17240	800
4	200	50	1180	5863	17.99	75	84	88	12910	960
5	200	50	980	2155	6.58	79	88	92	22125	0
6	200	50	980	2917	8.94	74	83	87	19165	275
7	200	50	980	3396	10.36	70	78	83	14225	545
8	200	50	980	3241	9.94	70	79	83	10605	648
9	200	50	780	1086	3.32	74	83	86	17610	0
10	200	50	780	1471	4.51	69	77	81	15255	174
11	200	50	780	1712	5.22	65	73	77	11320	345
12	200	50	780	1634	5.01	65	73	78	8440	411
13	200	50	590	470	1.44	67	76	79	13320	0
14	200	50	590	637	1.95	62	70	74	11540	100
15	200	50	590	741	2.26	58	66	70	8565	198
16	200	50	590	707	2.17	58	66	71	6385	235

U = Supply voltage · f = Frequency · n = Speed · P_{ed} = Power input · I = Current draw · LpA_{in} = Sound pressure level inlet side · LwA_{in} = Sound power level inlet side · LwA_{out} = Sound power level outlet side
 qv = Air flow · p_{fs} = Pressure increase

