

backward curved, single inlet

with support bracket

ebm-papst Mulfingen GmbH & Co. KG

Bachmühle 2 · D-74673 Mulfingen

Phone +49 7938 81-0

Fax +49 7938 81-110

sales@fansco.com

www.fansco.com

Limited partnership · Headquarters Mulfingen

County court Stuttgart · HRA 590344

General partner Elektrobau Mulfingen GmbH · Headquarters Mulfingen

County court Stuttgart · HRB 590142

Nominal data

Type	K3G450-PB24-01	
Motor	M3G150-IF	
Phase		3~
Nominal voltage	VAC	400
Nominal voltage range	VAC	380 .. 480
Frequency	Hz	50/60
Type of data definition		ml
Speed (rpm)	min ⁻¹	2600
Power input	W	5250
Current draw	A	8
Min. ambient temperature	°C	-25
Max. ambient temperature	°C	50

ml = Max. load · me = Max. efficiency · fa = Running at free air · cs = Customer specs · cu = Customer unit
Subject to alterations

Data in accordance with ecodesign regulation EU 327/2011

		Actual	Request 2015			
01 Overall efficiency η_{es}	%	69.2	59	09 Power input P_{ed}	kW	5.22
02 Measurement category		A		09 Air flow q_v	m ³ /h	7865
03 Efficiency category		Static		09 Pressure increase p_{fs}	Pa	1606
04 Efficiency grade N		72.2	62	10 Speed (rpm) n	min ⁻¹	2620
05 Variable speed drive		Yes		11 Specific ratio*		1.02

Data definition with optimum efficiency.

The ErP data is determined using a motor-impeller combination in a standardised measurement configuration.

* Specific ratio = $1 + p_{fs} / 100\,000\text{ Pa}$

LU-176459



backward curved, single inlet
with support bracket

Technical features

Mass	49 kg
Size	450 mm
Motor size	150
Surface of rotor	Coated in black
Material of electronics housing	Die-cast aluminium
Material of impeller	Aluminium sheet
Material of mounting plate	Sheet steel, galvanised
Material of support bracket	Steel, coated in black
Material of inlet nozzle	Sheet steel, galvanised
Number of blades	5
Direction of rotation	Clockwise, seen on rotor
Type of protection	IP55
Insulation class	"F"
Humidity (F) / environmental protection class (H)	H1
Max. permissible ambient motor temp. (transp./ storage)	+80 °C
Min. permissible ambient motor temp. (transp./storage)	-40 °C
Mounting position	Refer to product drawing
Condensation drainage holes	Rotor-side
Operation mode	S1
Motor bearing	Ball bearing
Technical features	<ul style="list-style-type: none"> - Output 10 VDC, max. 10 mA - Output 20 VDC, max. 50 mA - Output for slave 0-10 V - Operation and alarm display - Input for sensor 0-10 V or 4-20 mA - External 24 V input (programming) - External release input - Alarm relay - Integrated PID controller - Output limit - Motor current limit - PFC, passive - RS485 MODBUS RTU - Soft start - Control input 0-10 VDC / PWM - Control interface with SELV potential safely disconnected from the mains - Over-temperature protected electronics / motor - Line undervoltage / phase failure detection
EMC interference immunity	Acc. to EN 61000-6-2 (industrial environment)
EMC interference emission	Acc. to EN 61000-6-3 (household environment), except EN 61000-3-2 for professionally used devices with a total rated power greater than 1 kW
Touch current acc. IEC 60990 (measuring network Fig. 4, TN system)	<= 3.5 mA
Electrical connection	Terminal box
Motor protection	Reverse polarity and locked-rotor protection

K3G450-PB24-01

EC centrifugal module - RadiPac

backward curved, single inlet

with support bracket

Protection class	I (if protective earth is connected by customer)
Product conforming to standard	EN 61800-5-1; CE
Approval	CSA C22.2 no. 77 + CAN/CSA-E60730-1; EAC; UL 1004-7 + 60730-1



EC centrifugal module - RadiPac

backward curved, single inlet
with support bracket

Product drawing

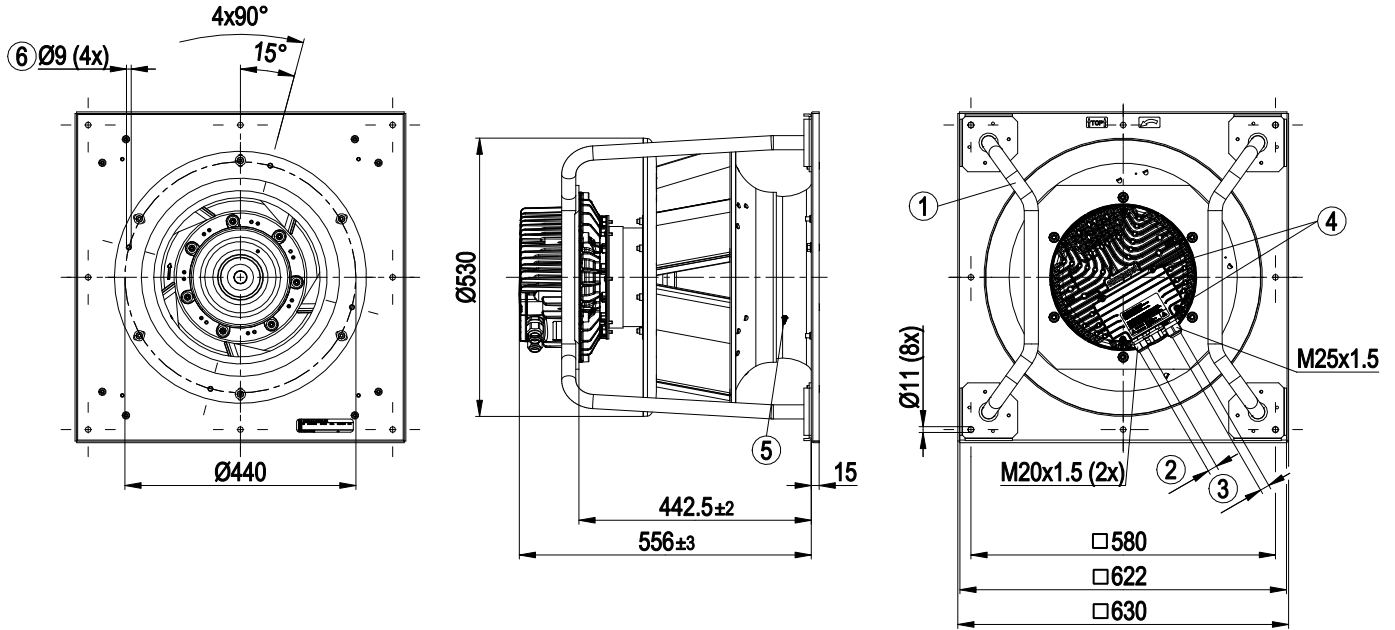

1	Installation position: Shaft horizontal (install the support struts only vertically as shown in the illustration!) or rotor on bottom; rotor on top on request
2	Cable diameter min. 4 mm, max. 10 mm, tightening torque 4 ± 0.6 Nm
3	Cable diameter min. 9 mm, max. 16 mm, tightening torque 6 ± 0.9 Nm
4	Tightening torque 3.5 ± 0.5 Nm
5	Inlet nozzle with pressure tap (k-factor: 240)
6	Mounting holes for FlowGrid

backward curved, single inlet
with support bracket

Connection screen

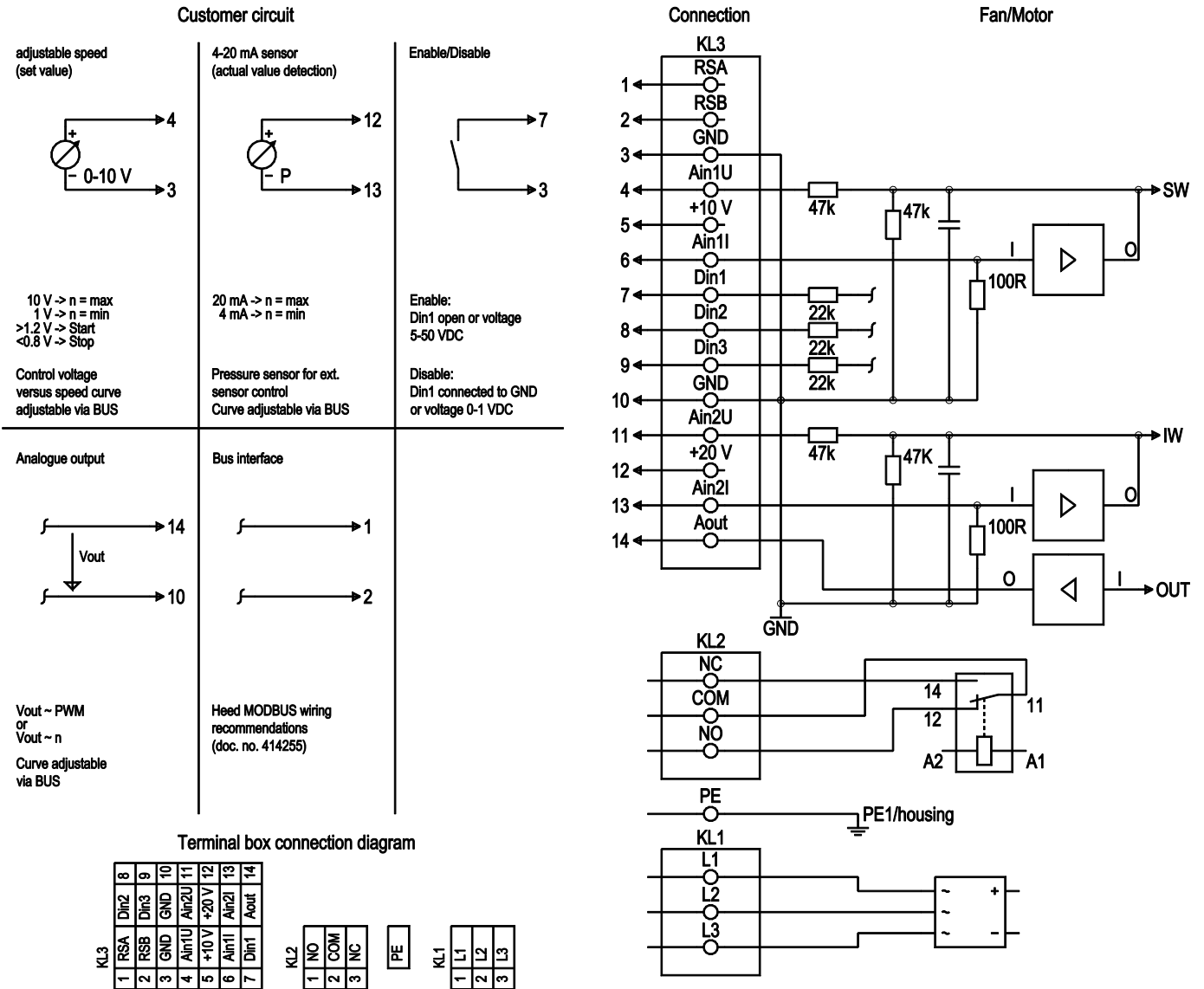

No.	Conn.	Designation	Function / assignment
KL 1	1	L1	Mains connection, power supply, phase, see type plate for voltage range
KL 1	2	L2	Mains connection, power supply, phase, see type plate for voltage range
KL 1	3	L3	Mains connection, power supply, phase, see type plate for voltage range
PE		PE	Earth connection, PE connection
KL 2	1	NO	Status relay, floating status contact, make for failure
KL 2	2	COM	Status relay, floating status contact, changeover contact, common connection, contact rating, max. 250 VAC/2 A (AC1)/min. 10 mA
KL 2	3	NC	Status relay, floating status contact, break for failure
KL 3	1	RSA	Bus connection RS485, RSA, MODBUS RTU; SELV
KL 3	2	RSB	Bus connection RS485, RSB, MODBUS RTU; SELV
KL 3	3 / 10	GND	Signal ground for control interface, SELV
KL 3	4	Ain1 U	Analogue input 1, set value: 0-10 V, Ri = 100 kΩ, parametrisable curve, only for use as alternative to input Ain1; SELV



EC centrifugal module - RadiPac

backward curved, single inlet

with support bracket

No.	Conn.	Designation	Function / assignment
KL 3	5	+ 10 V	Fixed voltage output 10 VDC, +10 V +/-3 %, max. 10 mA, short-circuit-proof, power supply for ext. devices (e.g. potentiometer); SELV
KL 3	6	Ain1 I	Analogue input 1, set value: 4-20 mA; Ri = 100 Ω, parametrisable curve, only for use as alternative to input Ain1 U; SELV
KL 3	7	Din1	Digital input 1: Enabling of electronics, Enabling: Pin open or applied voltage 5-50 VDC Disabling: Bridge to GND or applied voltage <1 VDC Reset function: Triggers software reset after a level change to <1 VDC; SELV
KL 3	8	Din2	Digital input 2: Parameter set 1/2 switching, depending on EEPROM setting, the valid/used parameter set can be selected via the bus or via the digital input DIN2. Parameter set 1: Pin open or applied voltage 5-50 VDC Parameter set 2: bridge to GND or applied voltage <1 VDC; SELV
KL 3	9	Din3	Digital input 3: Controller function of integrated controller; depending on EEPROM setting, normal / inverse can be selected for the controller function of the integrated controller via the bus or the digital input Normal: Pin open or applied voltage 5-50 VDC Inverse: bridge to GND or applied voltage <1 VDC; SELV
KL 3	11	Ain2 U	Analogue input 2, actual value: 0-10 V, Ri = 100 kΩ, parametrisable curve, only usable as alternative to input Ain2; SELV
KL 3	12	+ 20 V	Fixed voltage output 20 VDC, +20 V +25/-10%, max. 50 mA, short-circuit-proof, power supply for ext. devices (e.g. sensors); SELV Alternatively: +24 VDC input for parametrisation without mains power
KL 3	13	Ain2 I	Analogue input 2, actual value: 4-20 mA, Ri = 100 Ω, parametrisable curve, only for use as alternative to input Ain2 U; SELV
KL 3	14	Aout	Analogue output 0-10 V, max. 5 mA, output of current motor level control coefficient; parametrisable curve; SELV



EC centrifugal module - RadiPac

backward curved, single inlet
with support bracket

Charts: Air flow 50 Hz

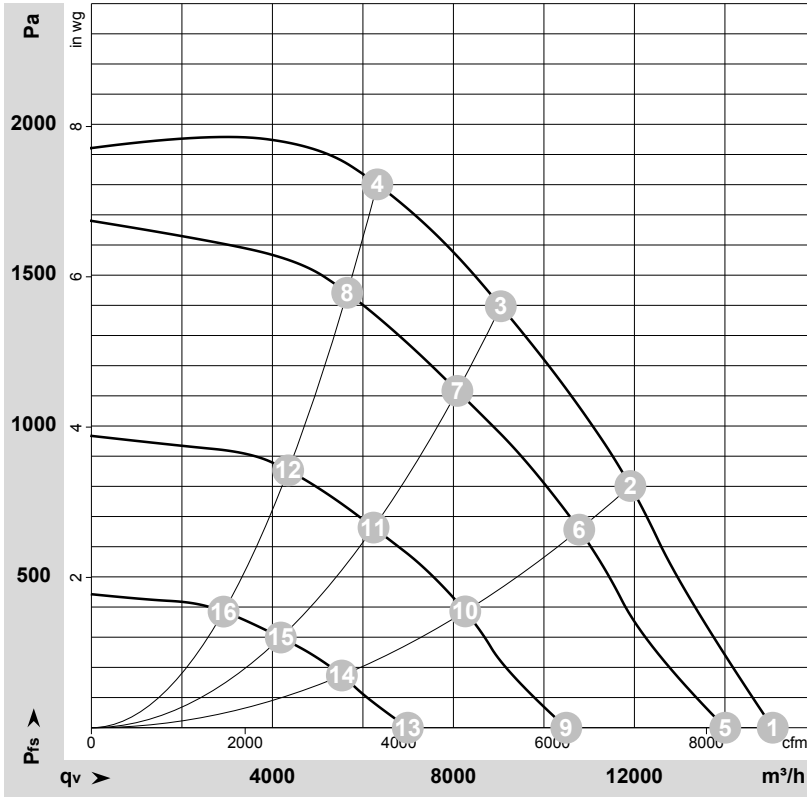

$\rho = 1.15 \text{ kg/m}^3 \pm 2 \%$

Measurement: LU-176459-1

Air performance measured as per ISO 5801 Installation category A. For detailed information on the measuring set-up, please contact ebmpapst. Suction-side noise levels: LwA measured as per ISO 13347 / LpA measured with 1m distance to fan axis. The values given are valid under the measuring conditions mentioned above and may vary according to the actual installation situation. With any deviation from the standard set-up, the specific values have to be checked and reviewed with the unit installed.

Measured values

	U	f	n	P _{ed}	I	LpA _{in}	LwA _{in}	LwA _{out}	q _v	P _{fs}	q _v	P _{fs}
	V	Hz	min ⁻¹	W	A	dB(A)	dB(A)	dB(A)	m ³ /h	Pa	cfm	in. wg
1	400	50	2600	3067	4.78	95	102	102	15055	0	8860	0.00
2	400	50	2600	4640	7.13	85	92	97	11910	800	7010	3.21
3	400	50	2600	5250	8.00	80	87	96	9045	1400	5325	5.62
4	400	50	2600	5141	7.89	84	91	97	6320	1800	3720	7.23
5	400	50	2430	2502	3.95	92	99	100	14010	0	8245	0.00
6	400	50	2360	3460	5.36	82	89	96	10780	660	6345	2.65
7	400	50	2335	3767	5.81	77	84	95	8090	1117	4760	4.48
8	400	50	2345	3677	5.68	80	87	95	5655	1445	3325	5.80
9	400	50	1840	1122	2.04	84	92	94	10495	0	6175	0.00
10	400	50	1815	1598	2.67	75	82	90	8260	388	4865	1.56
11	400	50	1800	1761	2.89	71	78	89	6235	663	3670	2.66
12	400	50	1805	1708	2.82	74	81	89	4350	855	2560	3.43
13	400	50	1235	402	0.84	74	81	85	6990	0	4115	0.00
14	400	50	1215	543	1.08	64	71	77	5535	176	3260	0.71
15	400	50	1210	594	1.17	62	69	76	4185	299	2465	1.20
16	400	50	1210	574	1.14	64	71	77	2920	386	1720	1.55

U = Supply voltage · f = Frequency · n = Speed (rpm) · P_{ed} = Power input · I = Current draw · LpA_{in} = Sound pressure level inlet side · LwA_{in} = Sound power level inlet side · LwA_{out} = Sound power level outlet side
q_v = Air flow · P_{fs} = Pressure increase

