

backward-curved, single-intake

with support bracket

ebm-papst Mulfingen GmbH & Co. KG

Bachmühle 2 · D-74673 Mulfingen

Phone +49 7938 81-0

Fax +49 7938 81-110

sales@fansco.com

www.fansco.com

Limited partnership · Headquarters Mulfingen

Amtsgericht (court of registration) Stuttgart · HRA 590344

General partner Elektrobau Mulfingen GmbH · Headquarters Mulfingen

Amtsgericht (court of registration) Stuttgart · HRB 590142

Nominal data

Type	K3G450-PA31-03	
Motor	M3G150-FF	
Phase		3~
Nominal voltage	VAC	400
Nominal voltage range	VAC	380 .. 480
Frequency	Hz	50/60
Method of obtaining data		ml
Speed (rpm)	min ⁻¹	2480
Power consumption	W	4500
Current draw	A	6.8
Min. ambient temperature	°C	-25
Max. ambient temperature	°C	40

ml = Max. load · me = Max. efficiency · fa = Free air · cs = Customer specification · ce = Customer equipment
Subject to change

Data according to Commission Regulation (EU) 327/2011

		Actual	Req. 2015
01 Overall efficiency η_{es}	%	69.6	58.3
02 Measurement category		A	
03 Efficiency category		Static	
04 Efficiency grade N		73.3	62
05 Variable speed drive		Yes	

Data obtained at optimum efficiency level.

The ErP data is determined using a motor-impeller combination in a standardized measurement setup.

09 Power consumption P_{ed}	kW	4.4
09 Air flow q_v	m ³ /h	8695
09 Pressure increase p_{fs}	Pa	1227
10 Speed (rpm) n	min ⁻¹	2475
11 Specific ratio*		1.01

* Specific ratio = $1 + p_{fs} / 100\,000\text{ Pa}$

LU-183215



Technical description

Weight	33.2 kg
Size	450 mm
Motor size	150
Rotor surface	Painted black
Electronics housing material	Die-cast aluminum
Impeller material	Sheet aluminum
Support plate material	Sheet steel, galvanized
Support bracket material	Steel, painted black
Inlet nozzle material	Sheet steel, galvanized
Number of blades	5
Direction of rotation	Clockwise, viewed toward rotor
Degree of protection	IP55
Insulation class	"F"
Moisture (F) / Environmental (H) protection class	H1
Ambient temperature note	Occasional start-up between -40°C and -25°C is permissible. For continuous operation at temperatures below -25°C (e.g. refrigeration applications) we recommend our fan design with special low-temperature bearings.
Max. permitted ambient temp. for motor (transport/storage)	+80 °C
Min. permitted ambient temp. for motor (transport/storage)	-40 °C
Installation position	See product drawing
Condensation drainage holes	On rotor side
Mode	S1
Motor bearing	Ball bearing
Technical features	<ul style="list-style-type: none"> - Operation and alarm display with LED - External 15-50 VDC input (parameterization) - Alarm relay - Integrated PI controller - Configurable inputs/outputs (I/O) - MODBUS V6.0 - Motor current limitation - RFID - ISO 15693 compatible - RS-485 MODBUS-RTU - Soft start - Voltage output 3.3-24 VDC, Pmax = 800 mW - Control interface with SELV potential safely disconnected from the mains - Thermal overload protection for electronics/motor - Line undervoltage / phase failure detection
Touch current according to IEC 60990 (measuring circuit Fig. 4, TN system)	<= 3.5 mA
Electrical hookup	Terminal box
Motor protection	Reverse polarity and locked-rotor protection
Protection class	I (with customer connection of protective earth)
Conformity with standards	EN 61800-5-1; CE
Approval	EAC

EC centrifugal module - RadiPac

backward-curved, single-intake

with support bracket

Product drawing

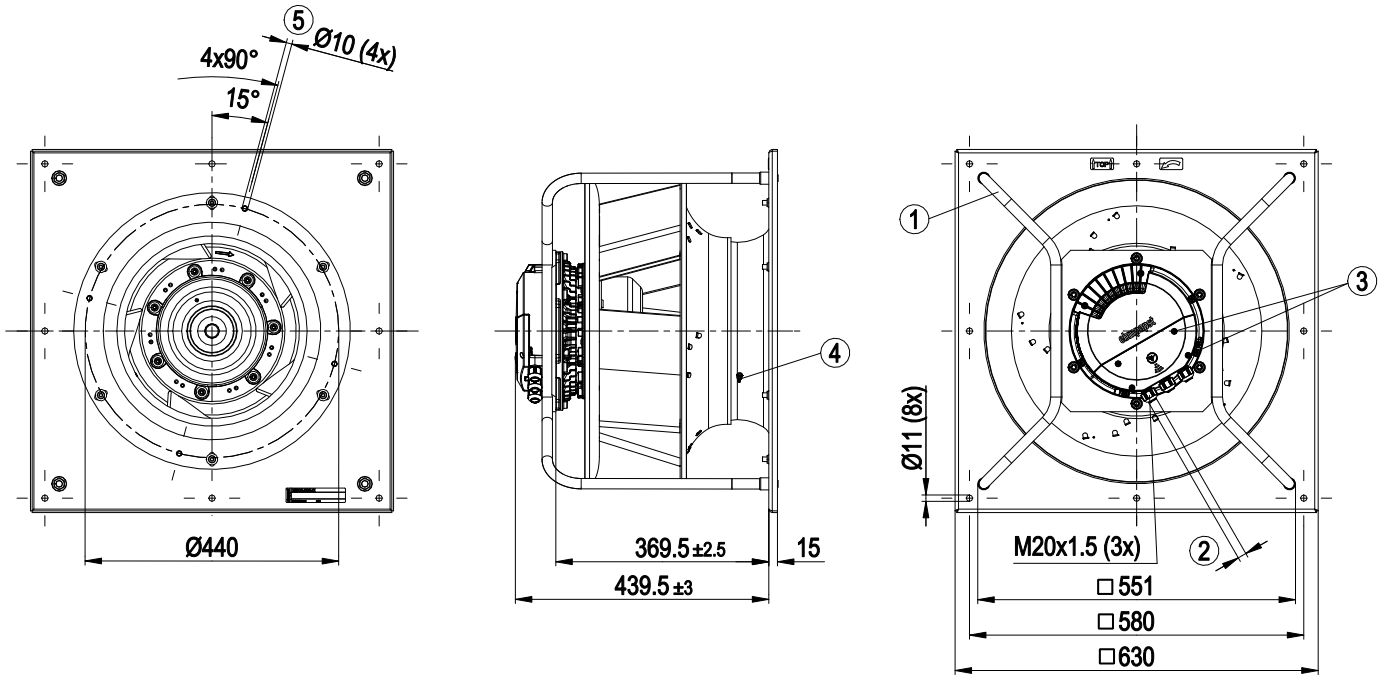

1	Installed position: shaft horizontal (install support struts only vertically as illustrated) or rotor on bottom; rotor on top on request
2	Cable diameter min. 4 mm, max. 10 mm, tightening torque 2 ± 0.3 Nm
3	Tightening torque 1.5 ± 0.2 Nm
4	Inlet ring with pressure tap (k-factor: 240)
5	Mounting holes for FlowGrid



EC centrifugal module - RadiPac

backward-curved, single-intake
with support bracket

Connection diagram

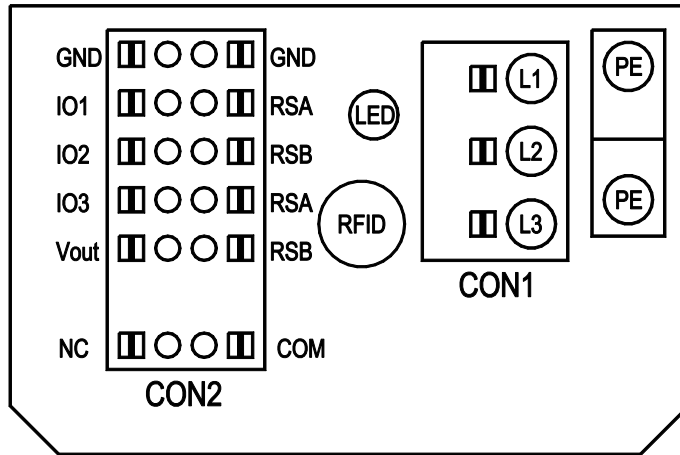

No.	Conn.	Designation	Function/assignment
CON1	-	L1, L2, L3	Supply connection, power supply, protection class 1
PE	-	PE	Ground connection, PE connection
CON2	-	RSA	Bus connection RS485, RSA, MODBUS-RTU; SELV
CON2	-	RSB	Bus connection RS485, RSB, MODBUS-RTU; SELV
CON2	-	GND	GND reference ground for control interface, SELV
CON2	-	IO1	IN2: Digital input - positive logic (factory setting: Enable) function parameterizable, SELV - normal: Pin open or applied voltage < 1.5 VDC - inverse: applied voltage 3.5-50 VDC
CON2	-	IO2	IN1: Analog input 0-10 V 0-10 V, Ri=100 K, parameterizable as set value or measured value (factory setting: set value) characteristic curve parameterizable, SELV
CON2	-	IO3	OUT1: Analog output 0-10 V 0-10 V, max 5 mA, function parameterizable (factory setting: modulation level) max output frequency 300 Hz, SELV
CON2	-	V out	Voltage output 3.3-24 VDC +/-5%, Pmax=800 mW, voltage parameterizable (factory setting: 10 VDC) short-circuit-proof, supply for external devices, SELV alternatively: 15-50 VDC input for parameterization via Modbus without line voltage
CON2	-	COM	Status relay, floating status contact; common connection, nominal voltage 250 VAC; max 2 A (AC1): min 10 mA; Reinforced insulation in accordance with EN60335-1, EN61800-5-1, UL60730-1
CON2	-	NC	Status relay, floating status contact, break for failure



Terminal/plug assignment

CON2	configurable IO mode	electrical specification	configurable IO functions: normal / inverse
101	○ Din1 (active high), digital input	not active: pin open or applied voltage < 1.5VDC active: applied voltage 3.5-50VDC, SELV	D158 [0]
	○ Ain1 0-10V/PWM: analog input	Ri=100k, characteristic curve parameterizable, f _{PWM} =1k..10kHz, SELV	D158 [2]
	○ Tacho out (open collector output)	U _{max} =50VDC, I _{max} =20mA, SELV	D158 [5]
	○ Diagnostics out (open collector output)	U _{max} =50VDC, I _{max} =20mA, SELV	D158 [6]
102	○ Din2 (active high), digital input	not active: pin open or applied voltage < 1.5VDC active: applied voltage 3.5-50VDC, SELV	D159 [0]
	○ Ain2 0-10V/PWM: analog input	Ri=100k, characteristic curve parameterizable, f _{PWM} =1k..10kHz, SELV	D159 [2]
	○ Ain2 4-20mA: analog input	Ri=125R, characteristic curve parameterizable, SELV	D159 [3]
	○ Din3 (active high), digital input	not active: pin open or applied voltage < 1.5VDC active: applied voltage 3.5-50VDC, SELV	D15A [0]
103	○ Din3 (active low), digital input	not active: pin open or applied voltage < 1.5VDC active: applied voltage 3.5-50VDC, SELV	D15A [1]
	○ PWMIn3: digital input	not active: pin open or applied voltage < 1.5VDC, SELV 40Hz - 10kHz, characteristics parameterizable	D15A [7]
	○ Aout3 0-10V: analog output	not active: pin open or applied voltage < 1.5VDC, SELV active: applied voltage < 1.5VDC, SELV	D15A [4]
	○ Tacho out (pulses), analog output	function parameterizable, max. 5mA, max output frequency 300Hz, SELV	D15A [5]
RSA RSB	○ Diagnostics out (pulses)	0-10V max. 5mA, max output frequency 300Hz, SELV 0-10V max. 5mA, max output frequency 300Hz, SELV	D15A [6]
	RS485 bus connection,	MODBUS RTU, specification V6.0, SELV	
Vout	voltage output	voltage parameterizable 3.3...24VDC +/- 5.5%, P _{max} =800mW, short-circuit-proof, supply for external devices, SELV	D16E [..]
	alternatively: input auxiliary power supply for parameterization via RS485/MODBUS RTU without line voltage	15...50VDC	

○ configurable option

For further information and additional functions see EC Control Software, Fan-Set-App, or MODBUS Parameter Specification V6.0



Curves: Air performance 50 Hz

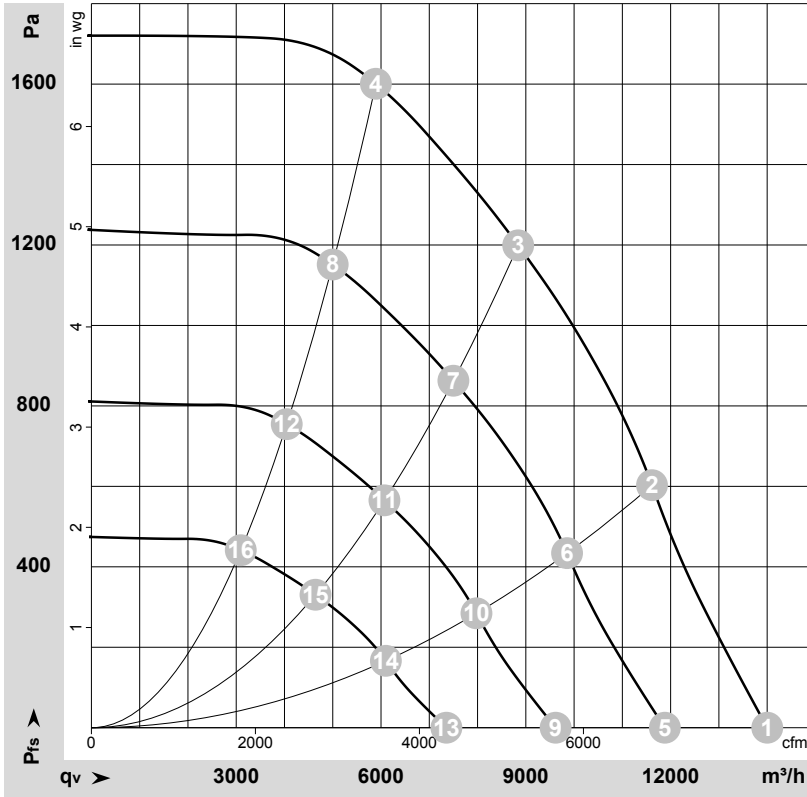

$\rho = 1.174 \text{ kg/m}^3 \pm 2 \%$

Measurement: LU-183215-1

Air performance measured according to ISO 5801 installation category A. For detailed information on the measurement setup, contact ebmpapst. Intake sound level: Sound power level according to ISO 13347 / sound pressure level measured at 1 m distance from fan axis. The values given are valid under the specified measuring conditions and may vary due to conditions of installation. For deviations from the standard configuration, the parameters have to be checked on the installed unit.

Measured values

	U	f	n	P _{ed}	I	LpA _{in}	LwA _{in}	LwA _{out}	q _v	P _{fs}	q _v	P _{fs}
	V	Hz	min ⁻¹	W	A	dB(A)	dB(A)	dB(A)	m ³ /h	Pa	cfm	in. wg
1	400	50	2480	2623	4.04	92	99	99	14000	0	8240	0.00
2	400	50	2480	3753	5.73	84	91	94	11615	600	6835	2.41
3	400	50	2480	4500	6.80	78	85	91	8840	1200	5205	4.82
4	400	50	2480	4356	6.65	83	89	93	5895	1600	3470	6.42
5	400	50	2100	1602	2.47	88	95	95	11880	0	6990	0.00
6	400	50	2100	2292	3.50	80	87	90	9855	434	5800	1.74
7	400	50	2100	2691	4.11	74	81	86	7500	864	4415	3.47
8	400	50	2100	2657	4.05	79	85	89	5000	1155	2940	4.64
9	400	50	1700	850	1.31	82	90	90	9620	0	5660	0.00
10	400	50	1700	1216	1.86	74	82	84	7975	285	4695	1.14
11	400	50	1700	1428	2.18	69	76	81	6070	566	3575	2.27
12	400	50	1700	1410	2.15	73	80	84	4045	757	2380	3.04
13	400	50	1300	380	0.59	75	83	83	7355	0	4330	0.00
14	400	50	1300	544	0.83	68	75	78	6100	166	3590	0.67
15	400	50	1300	638	0.97	62	69	74	4640	331	2730	1.33
16	400	50	1300	630	0.96	67	73	77	3095	443	1820	1.78

U = Voltage · f = Frequency · n = Speed (rpm) · P_{ed} = Power consumption · I = Current draw · LpA_{in} = Sound pressure level intake side · LwA_{in} = Sound power level intake side
LwA_{out} = Sound power level outlet side · q_v = Air flow · P_{fs} = Pressure increase

