

K3G097-AK36-55

EC dual centrifugal fan

forward-curved, dual-intake

with housing, Automotive



ebm-papst Mulfingen GmbH & Co. KG

Bachmühle 2 · D-74673 Mulfingen

Phone +49 7938 81-0

Fax +49 7938 81-110

sales@fansco.com

www.fansco.com

Limited partnership · Headquarters Mulfingen

Amtsgericht (court of registration) Stuttgart · HRA 590344

General partner Elektrobau Mulfingen GmbH · Headquarters Mulfingen

Amtsgericht (court of registration) Stuttgart · HRB 590142



Nominal data

Type	K3G097-AK36-55	
Motor	M3G074-CF	
Nominal voltage	VDC	13
Nominal voltage range	VDC	9 .. 15
Method of obtaining data		ml
Speed (rpm)	min ⁻¹	3570
Power consumption	W	335
Min. ambient temperature	°C	-40
Max. ambient temperature	°C	70

ml = Max. load · me = Max. efficiency · fa = Free air · cs = Customer specification · ce = Customer equipment
Subject to change

Data according to ErP Directive

		Actual	Req. 2015
01 Overall efficiency η_{es}	%	44.7	34.1
02 Measurement category		A	
03 Efficiency category		Static	
04 Efficiency grade N		54.6	44
05 Variable speed drive		Yes	

Data obtained at optimum efficiency level.

The ErP data is determined using a motor-impeller combination in a standardized measurement setup.

09 Power consumption P_e	kW	0.27
09 Air flow q_v	m ³ /h	600
09 Pressure increase p_{fs}	Pa	644
10 Speed (rpm) n	min ⁻¹	4920
11 Specific ratio*		1.01

* Specific ratio = $1 + p_{fs} / 100\,000\text{ Pa}$

LU-68238



EC dual centrifugal fan

forward-curved, dual-intake

with housing, Automotive

Technical description

Weight	2.3 kg
Fan size	97 mm
Impeller material	PA plastic UL94 HB (black)
Housing material	PP plastic (black)
Balancing grade according to DIN ISO 1940-1	G 2.5
Direction of rotation	Clockwise, viewed toward rotor
Degree of protection	IP24 KM
Insulation class	"B"
Moisture (F) / Environmental (H) protection class	F3-2
Max. permitted ambient temp. for motor (transport/storage)	+70 °C
Min. permitted ambient temp. for motor (transport/storage)	-40 °C
Installation position	Any
Condensation drainage holes	None, open rotor
Mode	S1
Motor bearing	Ball bearing; (sealed)
Life expectancy	40,000 h (typical)
Technical features	<ul style="list-style-type: none"> - Tach output - Power limiter - Load dump protection - Motor current limitation - Soft start - Control input 0-10 VDC / PWM - Thermal overload protection for electronics
Electrical hookup	Standby current less than 500 µA
Motor protection	Reverse polarity and locked-rotor protection
With cable	Variable
Approval	EAC
Sound level	76 dB(A), sound power level according to ISO 13347



EC dual centrifugal fan

forward-curved, dual-intake
with housing, Automotive

Product drawing

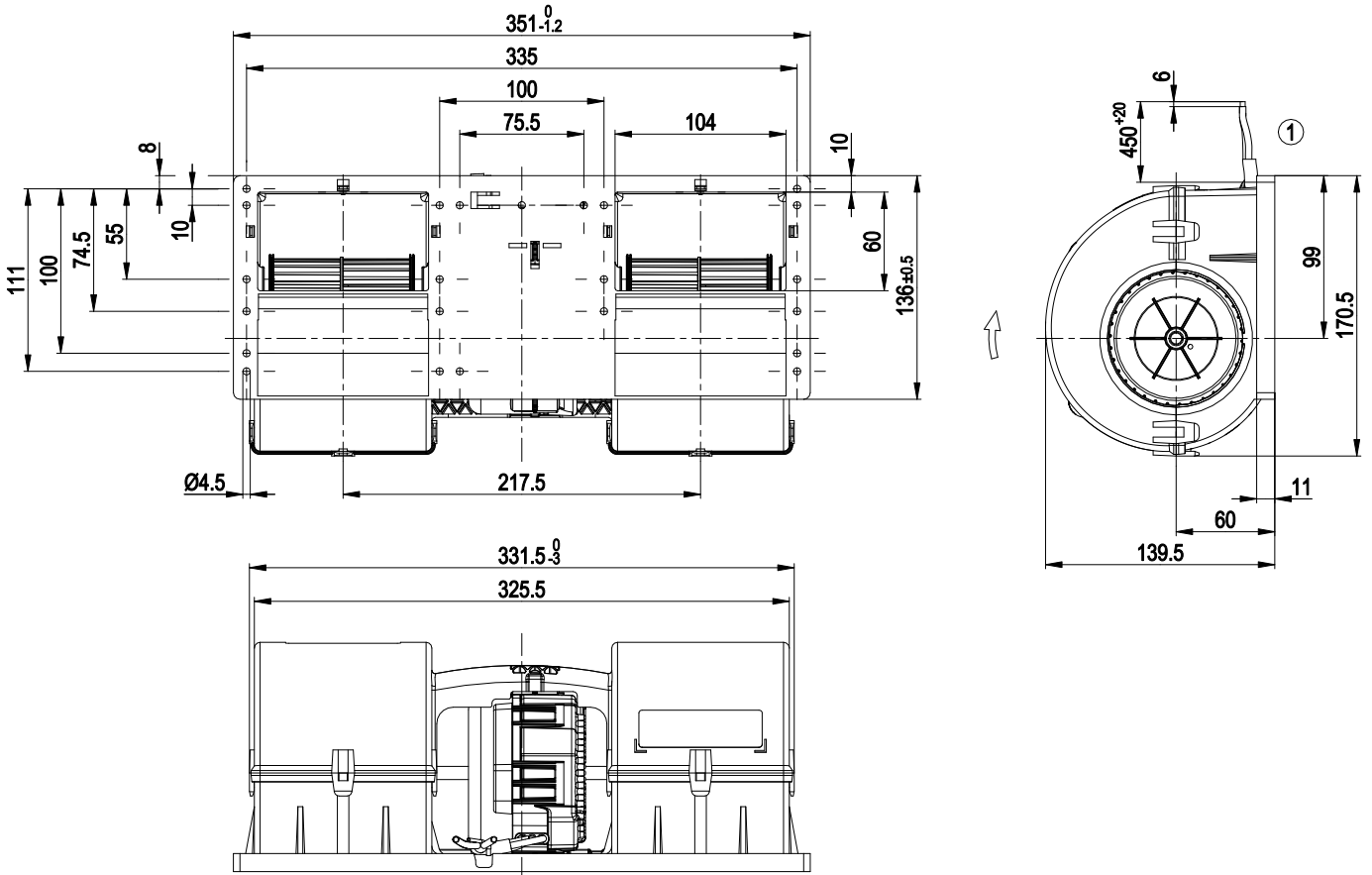

1	Cable FLRY 2x 4.0 mm ² , FLRY 1x 0.75 mm ² , 3x stripped and tin-plated wire ends
	+ UB (black)
	PWM/LIN (yellow)
	GND (brown)



EC dual centrifugal fan

forward-curved, dual-intake

with housing, Automotive

Connection diagram

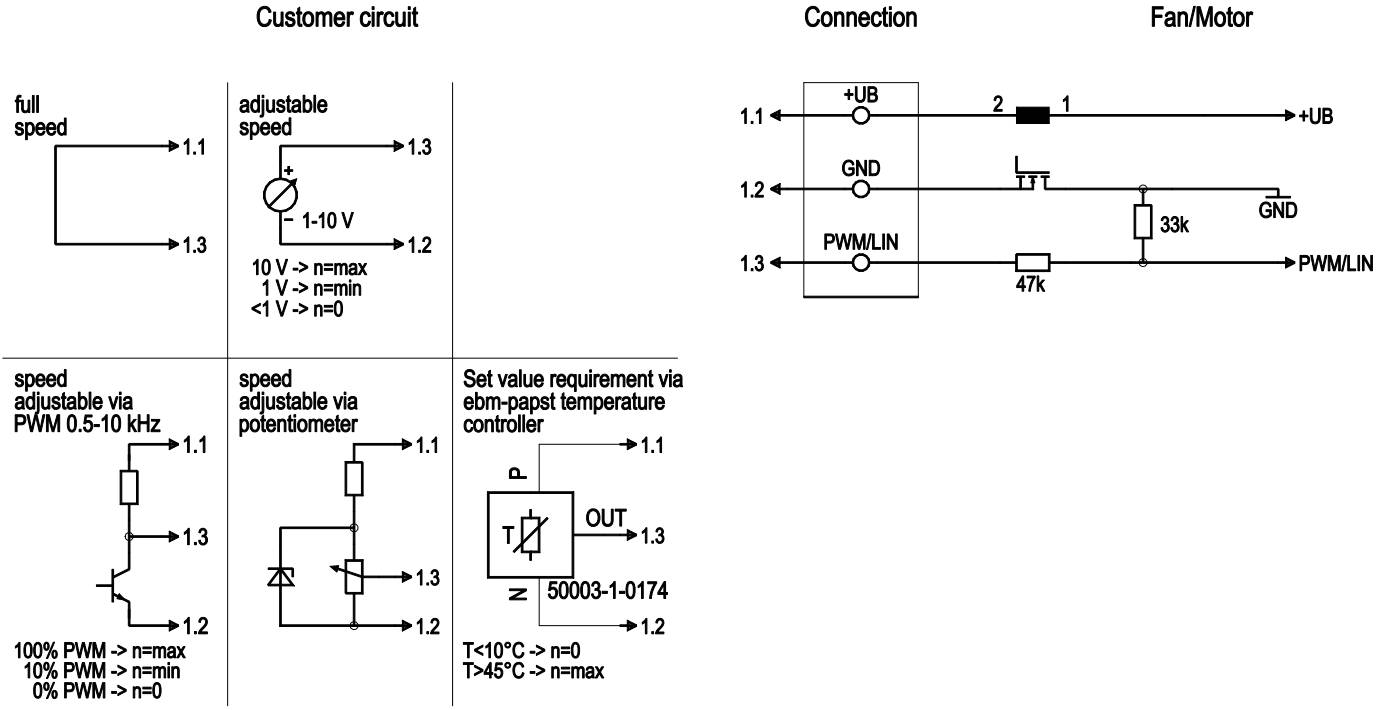

No.	Conn.	Designation	Color	Function/assignment
	1.1	+UB	black	Power supply
	1.2	GND	brown	Power supply GND, reference ground
	1.3	PWM/LIN	yellow	Control input Re > 100k



EC dual centrifugal fan

forward-curved, dual-intake

with housing, Automotive

Curves: Air performance

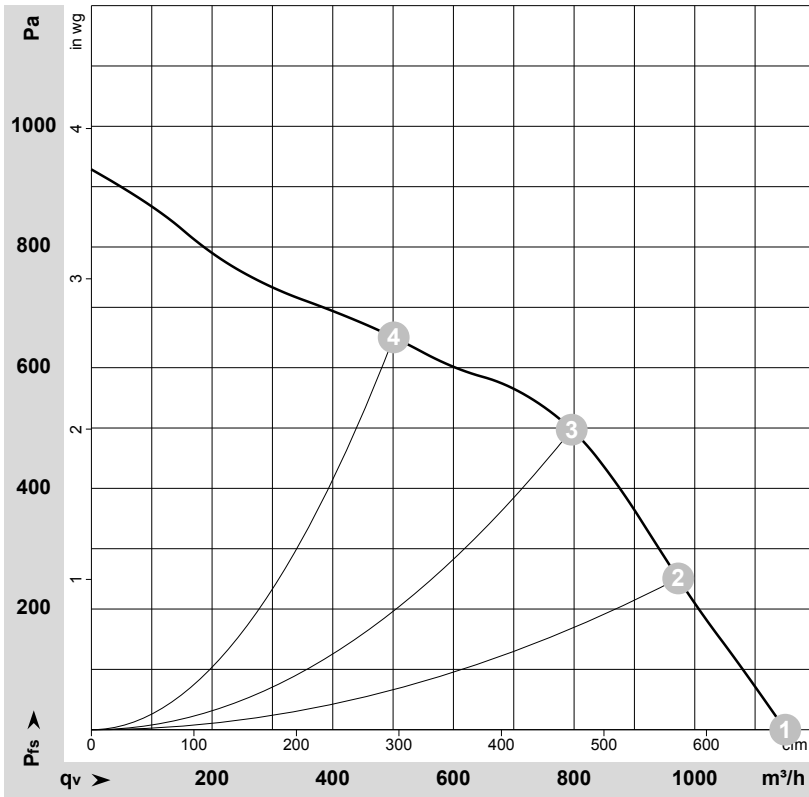

$\rho = 1.15 \text{ kg/m}^3 \pm 2 \%$

Measurement: LU-121049-1

Air performance measured according to ISO 5801 installation category A. For detailed information on the measurement setup, contact ebmpapst. Intake sound level: Sound power level according to ISO 13347 / sound pressure level measured at 1 m distance from fan axis. The values given are valid under the specified measuring conditions and may vary due to conditions of installation. For deviations from the standard configuration, the parameters have to be checked on the installed unit.

Measured values

	U	n	P _{ed}	I	qv	p _{fs}	qv	p _{fs}
	V	min ⁻¹	W	A	m ³ /h	Pa	CFM	inH ₂ O
1	13	3570	335	25.70	1150	0	675	0.00
2	13	3970	308	23.56	975	250	575	1.00
3	13	4405	304	23.20	795	500	470	2.01
4	13	4820	251	19.36	500	650	295	2.61

U = Power supply · n = Speed (rpm) · P_{ed} = Power consumption · I = Current draw · qv = Air flow · p_{fs} = Pressure increase

