

K1G220-AF90-02

# EC diagonal module - ESM

backward-curved  
with support bracket



## ebm-papst Mulfingen GmbH & Co. KG

Bachmühle 2 · D-74673 Mulfingen

Phone +49 7938 81-0

Fax +49 7938 81-110

sales@fansco.com

www.fansco.com

Limited partnership · Headquarters Mulfingen

Amtsgericht (court of registration) Stuttgart · HRA 590344

General partner Elektrobau Mulfingen GmbH · Headquarters Mulfingen

Amtsgericht (court of registration) Stuttgart · HRB 590142

## Nominal data

Type	K1G220-AF90-02		
Motor	M1G055-BD		
Phase		1~	1~
Nominal voltage	VAC	115	115
Frequency	Hz	50/60	50/60
Method of obtaining data		ml	
Speed (rpm)	min <sup>-1</sup>	1600	1200
Power consumption	W	32	
Current draw	A	0.5	
Min. ambient temperature	°C	-30	-30
Max. ambient temperature	°C	50	50

ml = Max. load · me = Max. efficiency · fa = Free air · cs = Customer specification · ce = Customer equipment  
Subject to change



### Technical description

<b>Weight</b>	1.4 kg
<b>Fan size</b>	220 mm
<b>Rotor surface</b>	Galvanized
<b>Impeller material</b>	PA plastic
<b>Support bracket material</b>	PA plastic
<b>Number of blades</b>	11
<b>Direction of rotation</b>	Clockwise, viewed toward rotor
<b>Degree of protection</b>	IP54
<b>Insulation class</b>	"B"
<b>Moisture (F) / Environmental (H) protection class</b>	H1
<b>Max. permitted ambient temp. for motor (transport/storage)</b>	+ 80 °C
<b>Min. permitted ambient temp. for motor (transport/storage)</b>	- 40 °C
<b>Installation position</b>	Any
<b>Condensation drainage holes</b>	On rotor side
<b>Mode</b>	S1
<b>Motor bearing</b>	Ball bearing
<b>Technical features</b>	<ul style="list-style-type: none"> <li>- Speed selection max./min.</li> <li>- ESM+ expandable with plug-in module</li> <li>- Soft start</li> <li>- Thermal overload protection for motor</li> </ul>
<b>Speed levels</b>	2
<b>EMC immunity to interference</b>	According to EN 61000-6-2
<b>EMC circuit feedback</b>	According to EN 61000-3-2/3
<b>EMC interference emission</b>	According to EN 61000-6-3 (household environment)
<b>Motor protection</b>	Thermal overload protector (TOP) internally connected
<b>Protection class</b>	II
<b>Conformity with standards</b>	EN 60335-1; EN 60335-2-24; EN 60335-2-80; EN 60335-2-89; CE
<b>Approval</b>	VDE; UL 1004-3; EAC; CSA C22.2 No. 77

## Product drawing

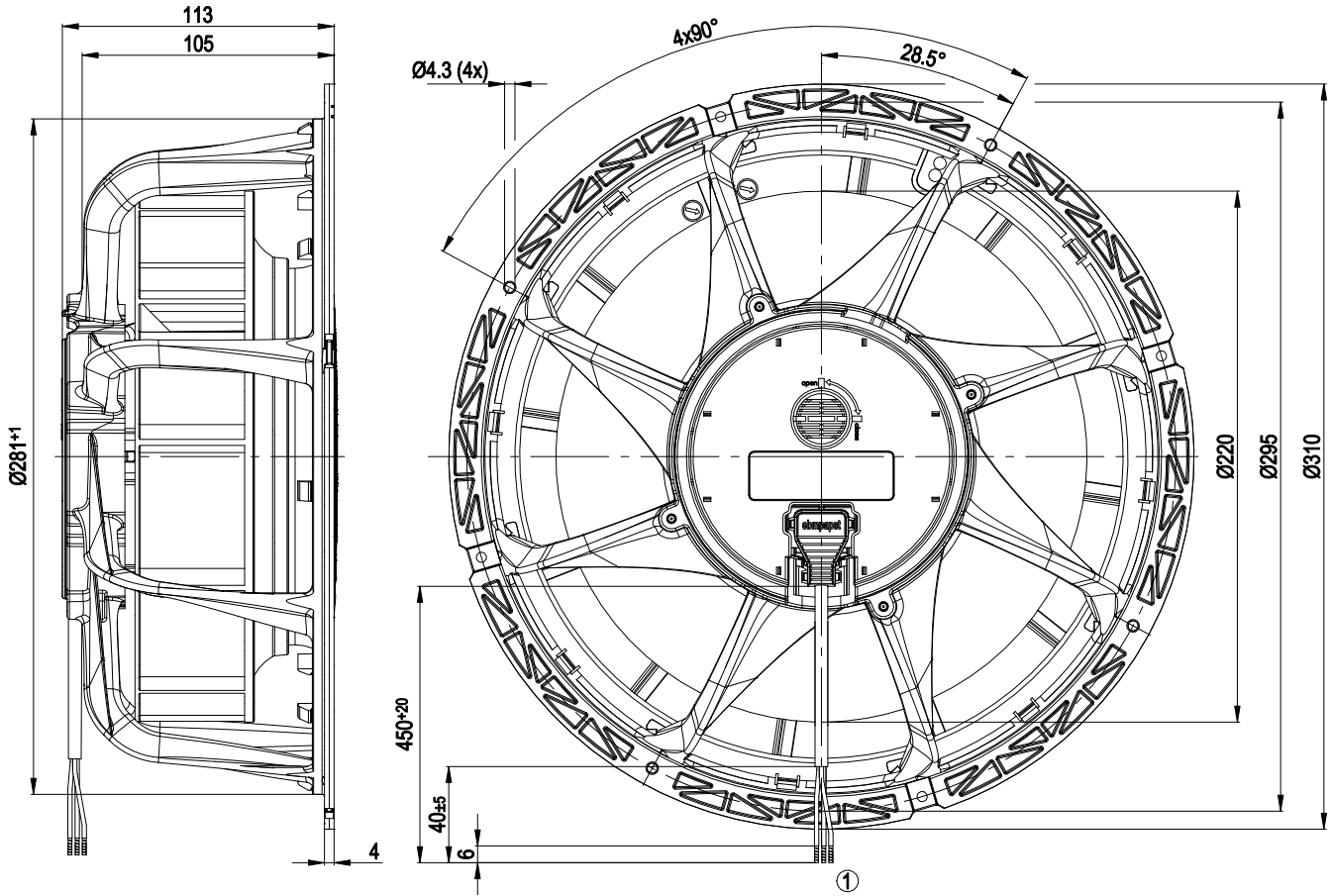

1 Cable AWG20, 3x crimped splices

## Connection diagram

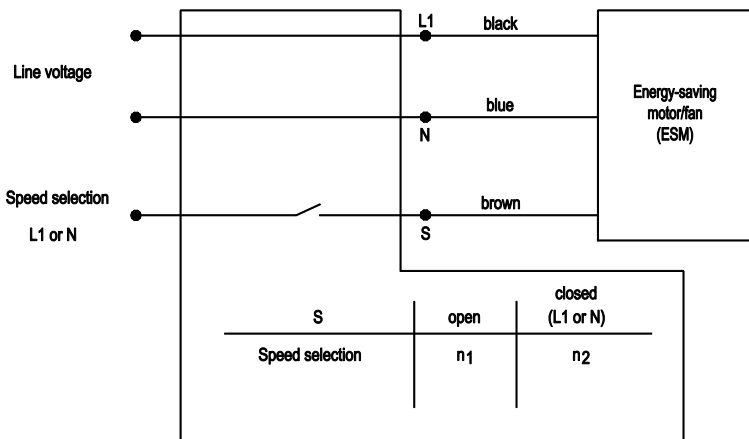

## Curves: Air performance 50 Hz

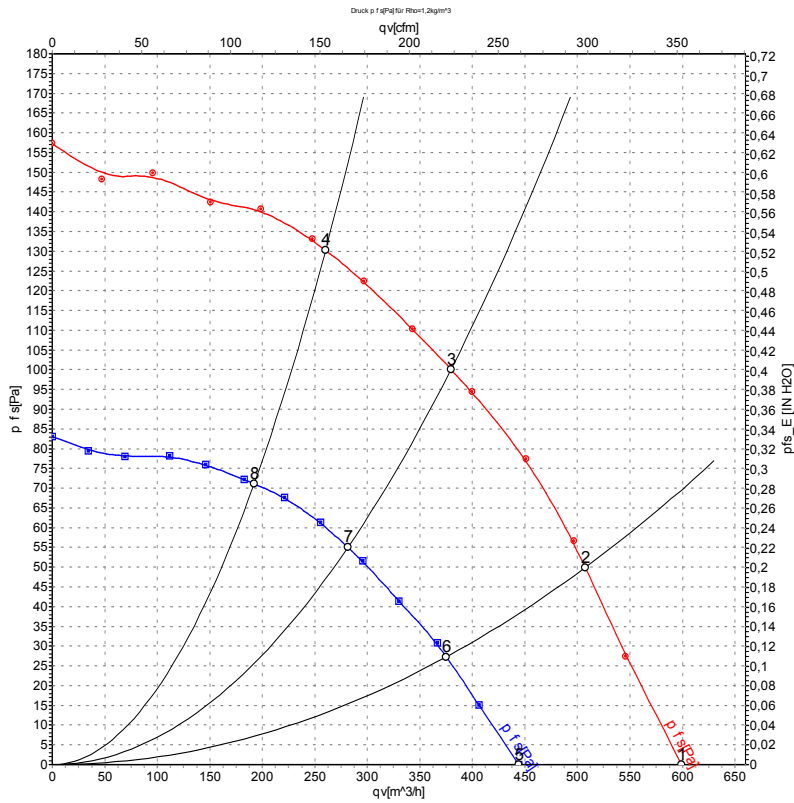

Measurement: LU-116724-1

Air performance measured according to ISO 5801 installation category A. For detailed information on the measurement setup, contact ebm-papst. Intake sound level: Sound pressure level according to ISO 13347 / sound pressure level measured at 1 m distance from fan axis. The values given are valid under the specified measuring conditions and may vary due to conditions of installation. For deviations from the standard configuration, the parameters have to be checked on the installed unit.

## Measured values

	U	f	n	P <sub>ed</sub>	I	LpA <sub>in</sub>	LwA <sub>in</sub>	q <sub>v</sub>	P <sub>fs</sub>	q <sub>v</sub>	P <sub>fs</sub>
	V	Hz	min <sup>-1</sup>	W	A	dB(A)	dB(A)	m³/h	Pa	cfm	inH2O
1	115	50	1600	18	0.25	51	59	600	0	355	0.00
2	115	50	1600	26	0.37	50	57	510	50	300	0.20
3	115	50	1600	32	0.50	48	55	380	100	225	0.40
4	115	50	1600	30	0.44	48	56	260	130	155	0.52
5	115	50	1200	7.2	0.10	44	52	445	0	260	0.00
6	115	50	1200	11	0.15	43	50	375	27	220	0.11
7	115	50	1200	12	0.18	41	48	280	55	165	0.22
8	115	50	1200	12	0.18	41	50	190	71	115	0.29

U = Power supply · f = Frequency · n = Speed (rpm) · P<sub>ed</sub> = Power consumption · I = Current draw · LpA<sub>in</sub> = Sound pressure level intake side · LwA<sub>in</sub> = Sound power level intake side  
q<sub>v</sub> = Air flow · P<sub>fs</sub> = Pressure increase

