

EC centrifugal fan - RadiCal

backward-curved, single-intake
with housing (without flange)

ebm-papst Mulfingen GmbH & Co. KG

Bachmühle 2 · D-74673 Mulfingen

Phone +49 7938 81-0

Fax +49 7938 81-110

sales@fansco.com

www.fansco.com

Limited partnership · Headquarters Mulfingen

Amtsgericht (court of registration) Stuttgart · HRA 590344

General partner Elektrobau Mulfingen GmbH · Headquarters Mulfingen

Amtsgericht (court of registration) Stuttgart · HRB 590142

Nominal data

Type	G3G190-RD45-03	
Motor	M3G055-CF	
Phase		1~
Nominal voltage	VAC	230
Nominal voltage range	VAC	200 .. 240
Frequency	Hz	50/60
Method of obtaining data		ml
Speed (rpm)	min ⁻¹	4120
Power consumption	W	169
Current draw	A	1.35
Min. back pressure	Pa	0
Min. back pressure	in. wg	0
Min. ambient temperature	°C	-25
Max. ambient temperature	°C	60

ml = Max. load · me = Max. efficiency · fa = Free air · cs = Customer specification · ce = Customer equipment
Subject to change

Data according to Commission Regulation (EU) 327/2011

		Actual	Req. 2015			
01 Overall efficiency η_{es}	%	63.4	42.1	09 Power consumption P_{ed}	kW	0.16
02 Measurement category		A		09 Air flow q_v	m ³ /h	460
03 Efficiency category		Static		09 Pressure increase p_{fs}	Pa	737
04 Efficiency grade N		82.3	61	10 Speed (rpm) n	min ⁻¹	4160
05 Variable speed drive		Yes		11 Specific ratio*		1.01

Data obtained at optimum efficiency level.

The ErP data is determined using a motor-impeller combination in a standardized measurement setup.

* Specific ratio = $1 + p_s / 100\,000\text{ Pa}$

LU-184317



Technical description

Weight	2.1 kg
Fan size	190 mm
Rotor surface	Thick-film passivated
Impeller material	PA plastic
Housing material	PP plastic
Number of blades	7
Direction of rotation	Clockwise, viewed toward rotor
Degree of protection	IP54; installation- and position-dependent
Insulation class	"B"
Max. permitted ambient temp. for motor (transport/storage)	+ 80 °C
Min. permitted ambient temp. for motor (transport/storage)	- 40 °C
Installation position	Any
Condensation drainage holes	None, open rotor
Mode	S1
Motor bearing	Ball bearing
Technical features	<ul style="list-style-type: none"> - Output 10 VDC, max. 10 mA - Tach output - Power limiter - Motor current limitation - Soft start - Control input 0-10 VDC / PWM - Control interface with SELV potential safely disconnected from the mains - Overvoltage detection - Thermal overload protection for electronics/motor - Line undervoltage detection
EMC immunity to interference	According to EN 61000-6-2 (industrial environment)
EMC interference emission	According to EN 61000-6-4 (industrial environment)
Touch current according to IEC 60990 (measuring circuit Fig. 4, TN system)	<= 3.5 mA
Motor protection	Electronic motor protection
With cable	Variable
Protection class	I (with customer connection of protective earth)
Conformity with standards	EN 60335-1; CE
Approval	C22.2 No.77 + CAN/CSA-E60730-1; UL 1004-7 + 60730; EAC

Product drawing

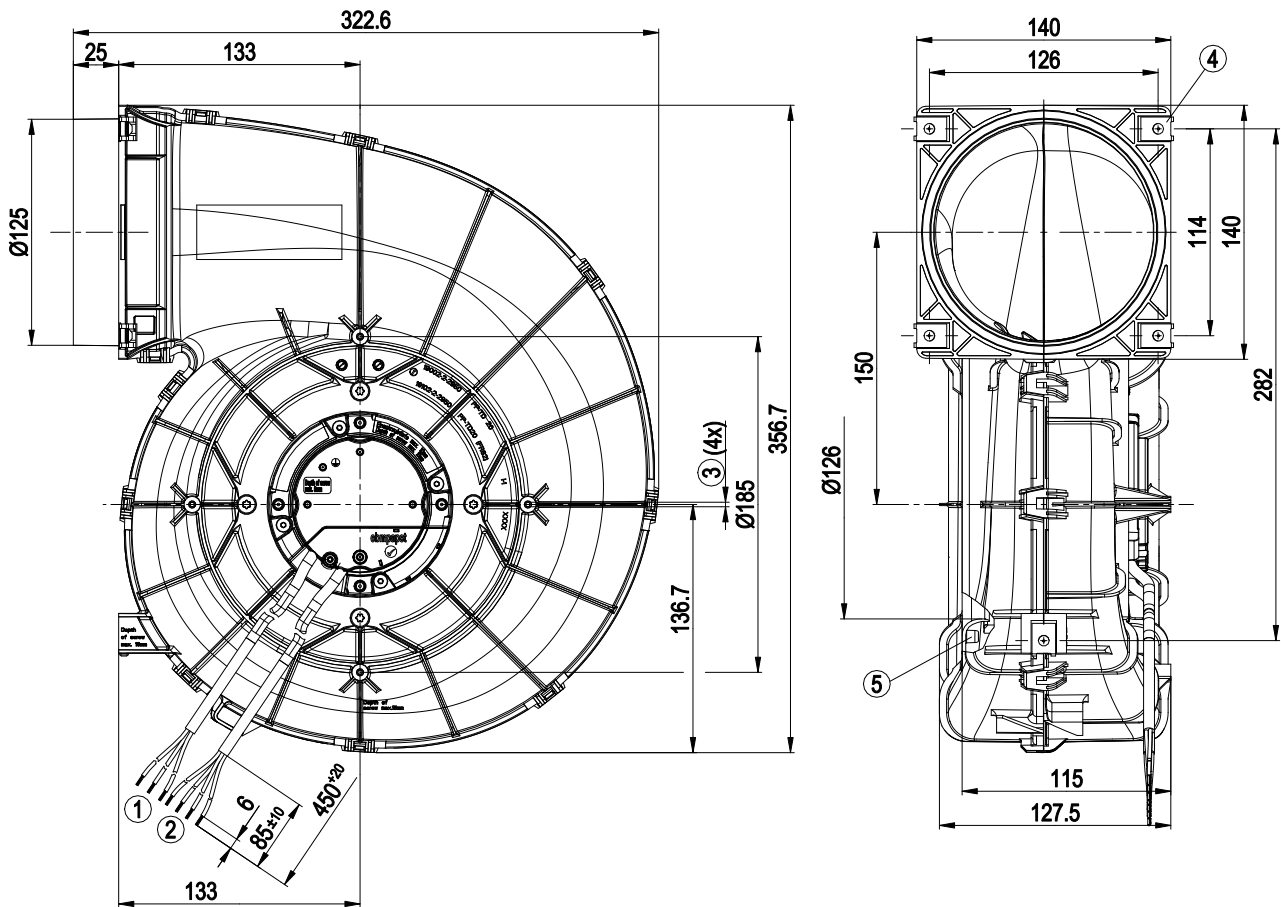

1	Cable PVC AWG20, 3x crimped splices
2	Cable PVC AWG22, 4x crimped splices
3	Tapping hole prepared for self-tapping screw for fastening plastics (Remform) dia. 4 mm, clearance for screw max. 15 mm. The torque is to be determined on the basis of the screw.
4	5x sheet metal nut for thread EN ISO 1478-ST4.8 (max. screw length 16 mm plus thickness of mounting material)
5	Screw-on domes are only permissible for Flowgrid!

EC centrifugal fan - RadiCal

backward-curved, single-intake
with housing (without flange)

Connection diagram

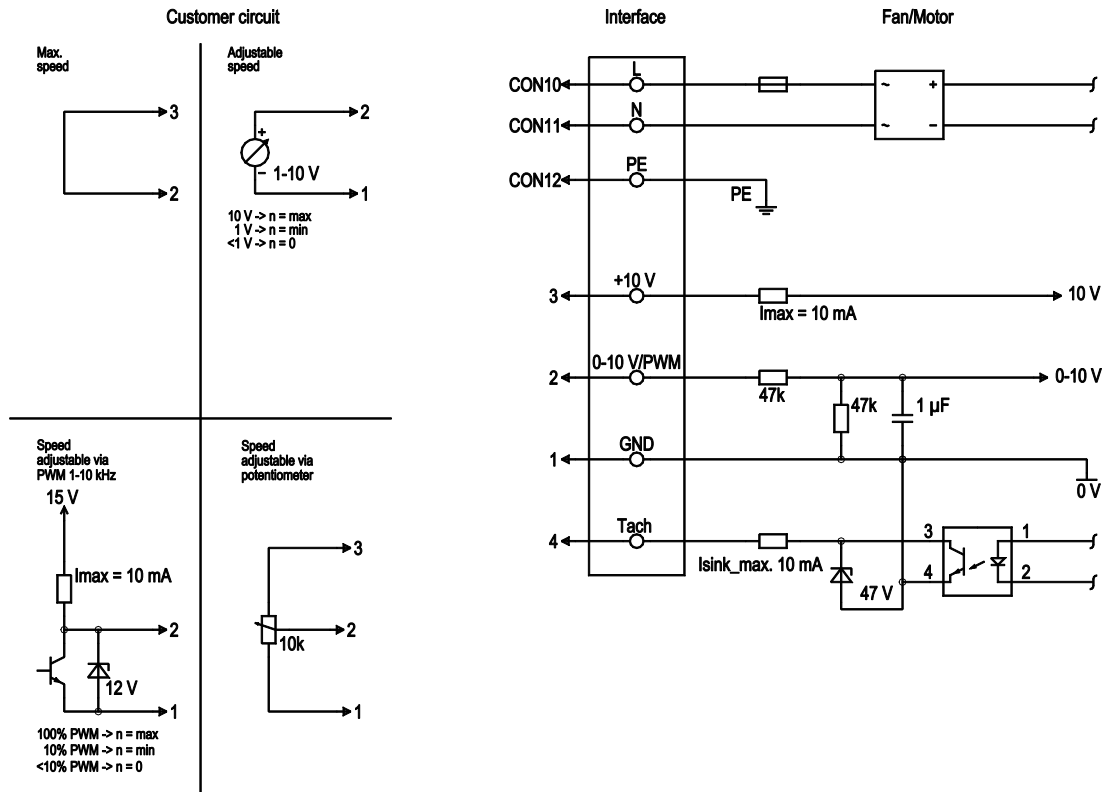

No.	Conn.	Designation	Color	Function/assignment
	CON10	L	black	Supply connection, power supply, phase, see nameplate for voltage range
	CON11	N	blue	Supply connection, power supply, neutral conductor, see nameplate for voltage range
	CON12	PE	green/yellow	Ground connection
	2	0- 10V PWM	yellow	0-10 V / PWM control input, R _i =100 kΩ, SELV
	4	Tach	white	Tach output, open collector, 1 pulse per revolution, I _{sink max} = 10 mA, SELV
	3	+10 V	red	Fixed voltage output 10 VDC +/-3 %, I _{max} . 10 mA, short-circuit-proof, power supply for ext. devices (e.g. pot), SELV
	1	GND	blue	Reference ground for control interface, SELV



EC centrifugal fan - RadiCal

backward-curved, single-intake
with housing (without flange)

Curves: Air performance 50 Hz

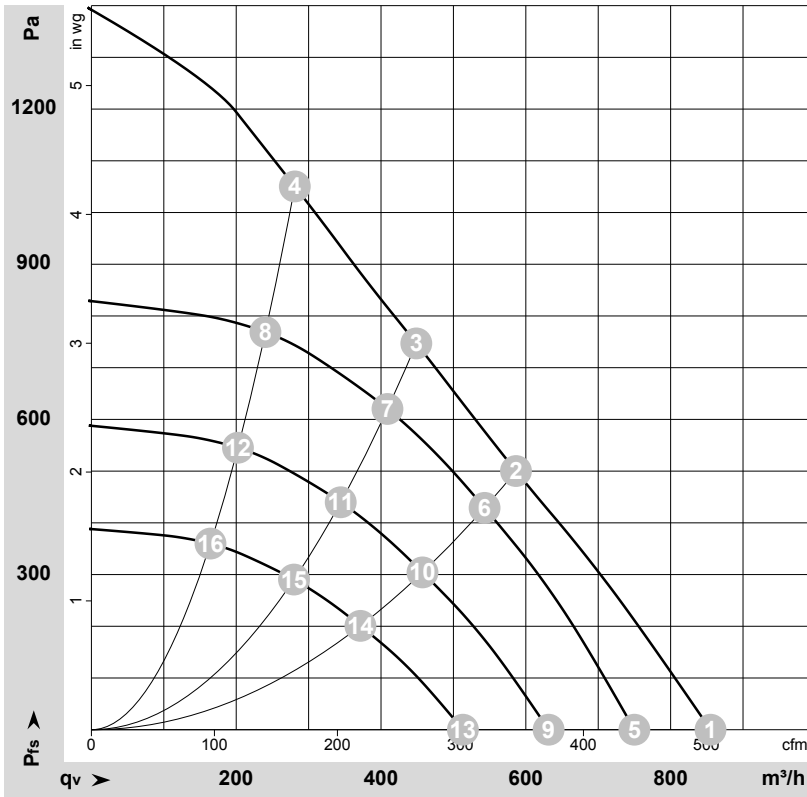

$\rho = 1.15 \text{ kg/m}^3 \pm 2 \%$

Measurement: LU-184317-1

Air performance measured according to ISO 5801 installation category A. For detailed information on the measurement setup, contact ebmpapst. Intake sound level: Sound power level according to ISO 13347 / sound pressure level measured at 1 m distance from fan axis. The values given are valid under the specified measuring conditions and may vary due to conditions of installation. For deviations from the standard configuration, the parameters have to be checked on the installed unit.

Measured values

	U	f	n	P _{ed}	I	LpA _{in}	LwA _{in}	q _v	P _{fs}	q _v	P _{fs}
	V	Hz	min ⁻¹	W	A	dB(A)	dB(A)	m ³ /h	Pa	cfm	in. wg
1	230	50	4335	169	1.35	75	80	855	0	505	0.00
2	230	50	4120	169	1.35	68	74	585	500	345	2.01
3	230	50	4165	169	1.35	67	74	450	750	265	3.01
4	230	50	4440	169	1.35	73	79	280	1050	165	4.22
5	230	50	3800	114	0.92	72	77	750	0	440	0.00
6	230	50	3800	133	1.08	66	72	545	429	320	1.72
7	230	50	3800	127	1.03	65	71	410	622	240	2.50
8	230	50	3800	104	0.85	69	75	240	769	140	3.09
9	230	50	3200	68	0.55	67	73	630	0	370	0.00
10	230	50	3200	79	0.65	62	68	455	304	270	1.22
11	230	50	3200	76	0.62	61	67	345	441	200	1.77
12	230	50	3200	62	0.51	64	70	200	545	120	2.19
13	230	50	2600	36	0.29	62	68	515	0	300	0.00
14	230	50	2600	43	0.35	56	63	370	201	220	0.81
15	230	50	2600	41	0.33	55	62	280	291	165	1.17
16	230	50	2600	33	0.27	59	65	165	360	95	1.45

U = Power supply · f = Frequency · n = Speed (rpm) · P_{ed} = Power consumption · I = Current draw · LpA_{in} = Sound pressure level intake side · LwA_{in} = Sound power level intake side
q_v = Air flow · p_{fs} = Pressure increase

