

G2E140-AL40-01

AC centrifugal fan

forward curved, single inlet

with housing (flange), for solid fuel heating systems



ebm-papst Mulfingen GmbH & Co. KG

Bachmühle 2 · D-74673 Mulfingen

Phone +49 7938 81-0

Fax +49 7938 81-110

sales@fansco.com

www.fansco.com

Limited partnership · Headquarters Mulfingen
County court Stuttgart · HRA 590344

General partner Elektrobau Mulfingen GmbH · Headquarters Mulfingen
County court Stuttgart · HRB 590142

Nominal data

Type	G2E140-AL40-01		
Motor	M2E068-CF		
Phase		1~	1~
Nominal voltage	VAC	230	230
Frequency	Hz	50	60
Type of data definition		fa	ml
Valid for approval / standard		CE	CE
Speed	min ⁻¹	1650	1700
Power input	W	135	145
Current draw	A	0.60	0.64
Motor capacitor	µF	2	2
Capacitor voltage	VDB	450	450
Capacitor standard		P0 (CE)	P0 (CE)
Min. back pressure	Pa	0	100
Min. ambient temperature	°C	-25	-25
Max. ambient temperature	°C	60	40

ml = max. load · me = max. efficiency · fa = running at free air · cs = customer specs · cu = customer unit
Subject to alterations



G2E140-AL40-01

AC centrifugal fan

forward curved, single inlet

with housing (flange), for solid fuel heating systems

Technical features

Mass	3.0 kg
Size	140 mm
Material of impeller	Sheet steel, hot-galvanised
Housing material	Die-cast aluminium
Direction of rotation	Clockwise, seen on rotor
Type of protection	IP 44
Insulation class	"B"
Humidity class	F0
Max. permissible ambient motor temp. (transp./ storage)	+ 80 °C
Min. permissible ambient motor temp. (transp./storage)	- 40 °C
Mounting position	Any
Condensate discharge holes	None
Operation mode	S1
Motor bearing	Ball bearing
Touch current acc. IEC 60990 (measuring network Fig. 4, TN system)	< 0.75 mA
Motor protection	Thermal overload protector (TOP) wired internally
Protection class	I (if protective earth is connected by customer)
Product conforming to standard	EN 60335-1; CE
Approval	CCC; GOST



AC centrifugal fan

forward curved, single inlet

with housing (flange), for solid fuel heating systems

Product drawing

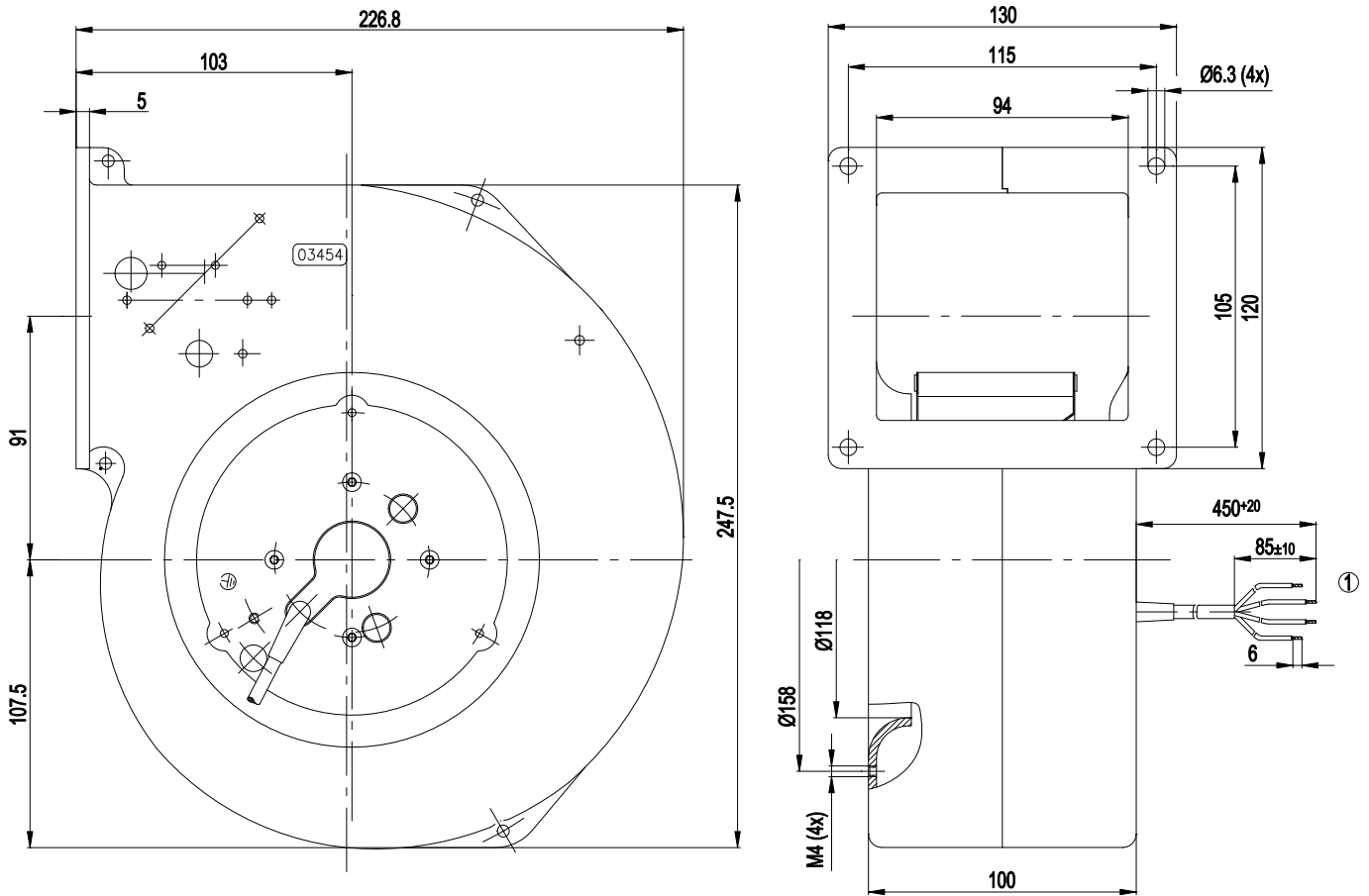

1 Connection line PVC 4G 0.5 mm², 4 x brass lead tips crimped

Connection screen

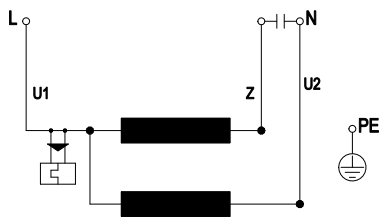

U1	blue	Z	brown	U2	black
PE	green/yellow				



AC centrifugal fan

forward curved, single inlet

with housing (flange), for solid fuel heating systems

Charts: Air flow 50 Hz

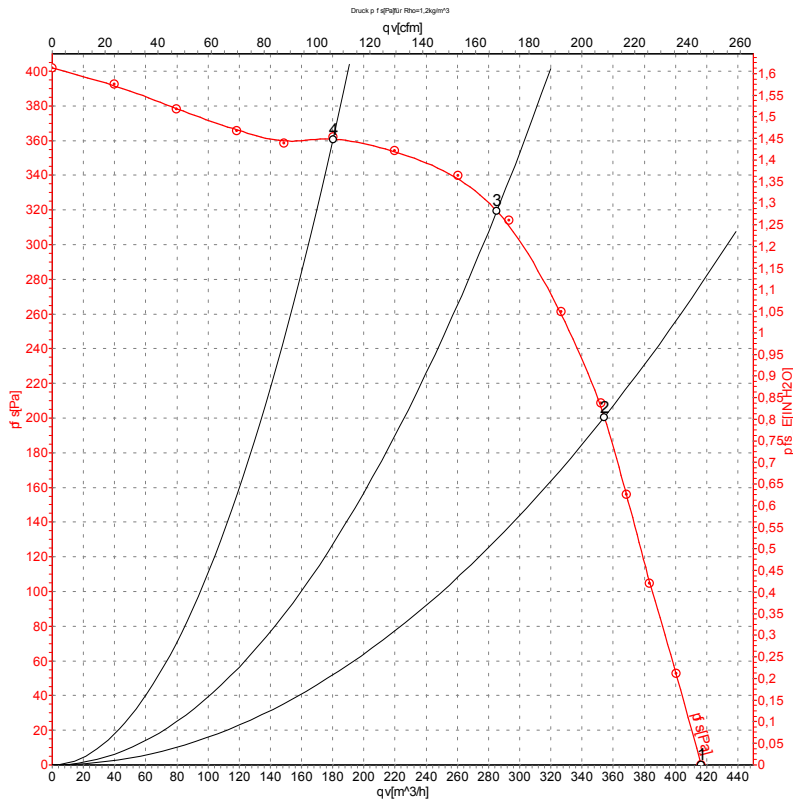

Measurement: LU-105094

Air performance measured as per ISO 5801 Installation category A. For detailed information on the measuring set-up, please contact ebm-papst. Suction-side noise levels: L_{wA} measured as per ISO 13347 / L_{pA} measured with 1m distance to fan axis. The values given are valid under the measuring conditions mentioned above and may vary according to the actual installation situation. With any deviation from the standard set-up, the specific values have to be checked and reviewed with the unit installed.

Measured values

	U	f	n	P _e	I	qv	P _{fs}
	V	Hz	min ⁻¹	W	A	m³/h	Pa
1	230	50	1650	135	0.60	415	0
2	230	50	2095	111	0.48	355	200
3	230	50	2350	98	0.43	285	320
4	230	50	2590	81	0.35	180	360

U = Supply voltage · f = Frequency · n = Speed · P_e = Power input · I = Current draw · qv = Air flow · P_{fs} = Pressure increase



AC centrifugal fan

forward curved, single inlet

with housing (flange), for solid fuel heating systems

Charts: Air flow 60 Hz

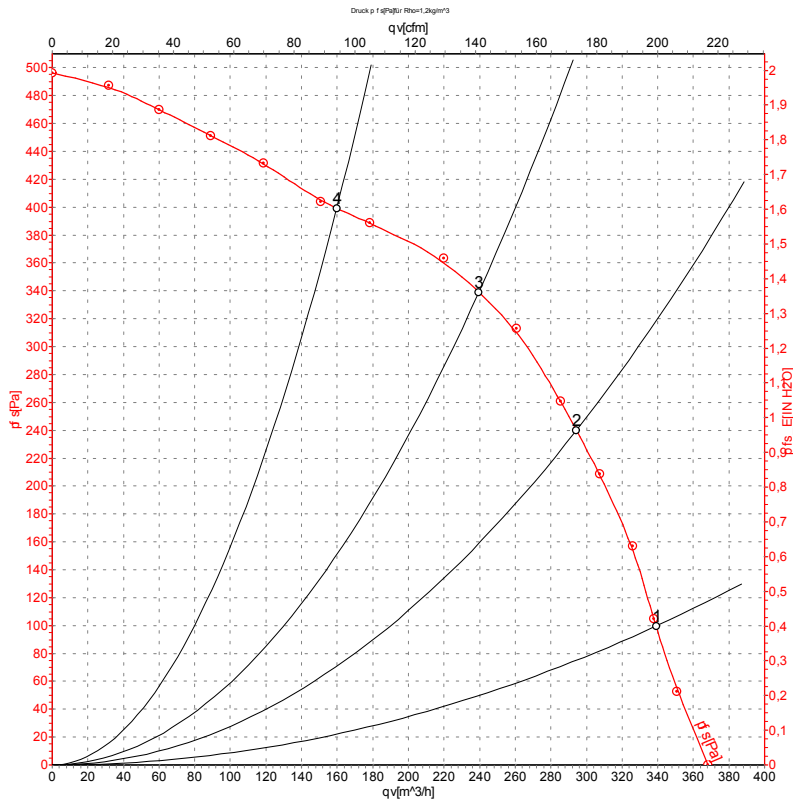

Measurement: LU-105095

Air performance measured as per ISO 5801 Installation category A. For detailed information on the measuring set-up, please contact ebm-papst. Suction-side noise levels: L_{wA} measured as per ISO 13347 / L_{pA} measured with 1m distance to fan axis. The values given are valid under the measuring conditions mentioned above and may vary according to the actual installation situation. With any deviation from the standard set-up, the specific values have to be checked and reviewed with the unit installed.

Measured values

	U	f	n	P _e	I	qv	P _{fs}
	V	Hz	min ⁻¹	W	A	m ³ /h	Pa
1	230	60	1700	145	0.64	340	100
2	230	60	2100	129	0.56	295	240
3	230	60	2425	123	0.54	240	340
4	230	60	2775	115	0.50	160	400

U = Supply voltage · f = Frequency · n = Speed · P_e = Power input · I = Current draw · qv = Air flow · P_{fs} = Pressure increase

