

G1G170-AB31-01

EC centrifugal fan

backward curved, single inlet

with housing (flange), Gas blower for gas-condensing heating



ebm-papst Mulfingen GmbH & Co. KG

Bachmühle 2 · D-74673 Mulfingen

Phone +49 7938 81-0

Fax +49 7938 81-110

sales@fansco.com

www.fansco.com

Limited partnership · Headquarters Mulfingen
County court Stuttgart · HRA 590344

General partner Elektrobau Mulfingen GmbH · Headquarters Mulfingen
County court Stuttgart · HRB 590142



Nominal data

Type	G1G170-AB31-01	
Motor	M1G074-CF	
Phase		1~
Nominal voltage	VAC	230
Frequency	Hz	50/60
Type of data definition		fa
Speed	min ⁻¹	5650
Power input	W	315
Current draw	A	2.15
Min. ambient temperature	°C	-25
Max. ambient temperature	°C	55
Min. temp. of flow medium	°C	-25
Max. temp. of flow medium	°C	+80

ml = max. load · me = max. efficiency · fa = running at free air · cs = customer specs · cu = customer unit
Subject to alterations

Data according to ErP directive

Installation category	A
Efficiency category	Static
Variable speed drive	Yes
Specific ratio*	1.02

* Specific ratio = $1 + p_{fs} / 100\,000\text{ Pa}$

	Actual	Request 2013	Request 2015
Overall efficiency η_{es}	61.3	41.9	44.9
Efficiency grade N	77.4	58	61
Power input P_{ed}	kW	0.29	
Air flow q_v	m ³ /h	370	
Pressure increase p_{fs}	Pa	1601	
Speed n	min ⁻¹	5960	

Data established at point of optimum efficiency



G1G170-AB31-01

EC centrifugal fan

backward curved, single inlet

with housing (flange), Gas blower for gas-condensing heating

Technical features

Mass	4.35 kg
Size	170 mm
Surface of rotor	Coated in black
Material of protective cover	Polyflam RPP 374-ND CS1 (UL 97-V0)
Material of impeller	Aluminium sheet
Housing material	Die-cast aluminium
Direction of rotation	Clockwise, seen on rotor
Type of protection	IP 20
Insulation class	"B"
Max. permissible ambient motor temp. (transp./ storage)	+80 °C
Min. permissible ambient motor temp. (transp./storage)	-40 °C
Mounting position	Any
Cooling bore / aperture	Rotor-side
Motor bearing	Ball bearing
Technical features	- Control input PWM - Motor current limit - Tach output - Overtemperature-protected motor
Touch current acc. IEC 60990 (measuring network Fig. 4, TN system)	<= 3.5 mA
Electrical leads	With plug
Motor protection	Thermal overload protector (TOP) wired internally
Product conforming to standard	CE
Approval	CCC; VDE; CSA C22.2 Nr.113; UL 507



EC centrifugal fan

backward curved, single inlet

with housing (flange), Gas blower for gas-condensing heating

Product drawing

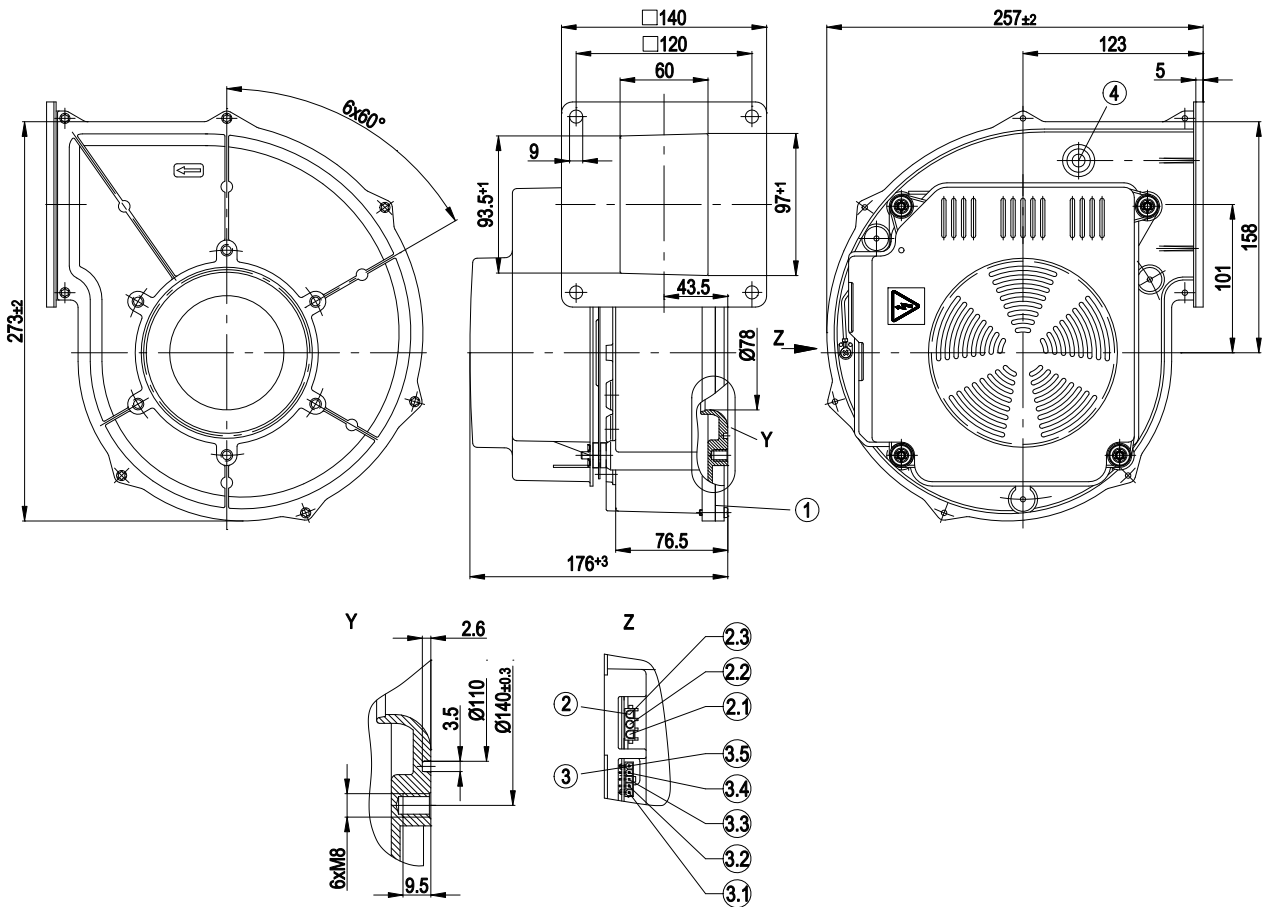

1	Housing side parts sealed with NBR round cord (pentane-resistant)
Z	View Z
2	3-pole strip; mating connector (not included in standard scope of delivery): tyco No. 350 766-1; female connector: No. 926 884-1
2.1	L
2.2	N
2.3	PE
3	5-pole strip; mating connector (not included in standard scope of delivery) Molex No. 39-01-4050, female connector Molex No. 39-00-0059
3.1	(+)
3.2	Speed monitoring
3.3	Not assigned
3.4	PWM input
3.5	(-)
4	Bleeder connection for pressure relief possible



EC centrifugal fan

backward curved, single inlet

with housing (flange), Gas blower for gas-condensing heating

Connection screen

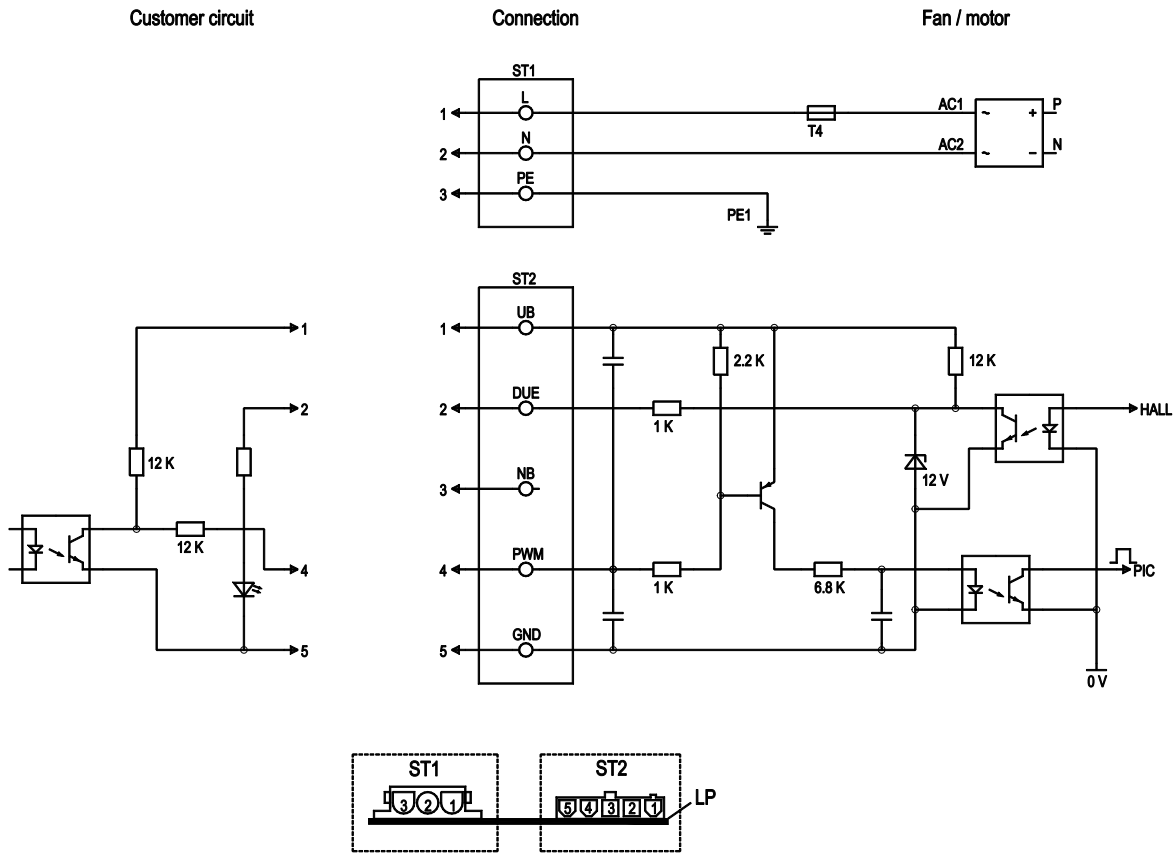

No.	Pin	Signal	Function / assignment
ST1	1, 2, 3	L, N, PE	Power supply 230 VAC, 50-60 Hz, neutral conductor, protective earth
ST2	1	UB	External voltage 24-45 VDC
ST2	2	Tach	Speed monitoring output connection, monitoring circuit output, 3 pulses per revolution, current source 1 mA
ST2	3	N.C.	Not assigned
ST2	4	PWM	PWM - 2 - 6 kHz control input, PWM on n = 100%, PWM low n = 0%
ST2	5	GND	GND - Connection for control interface



EC centrifugal fan

backward curved, single inlet

with housing (flange), Gas blower for gas-condensing heating

Charts: Air flow 50 Hz

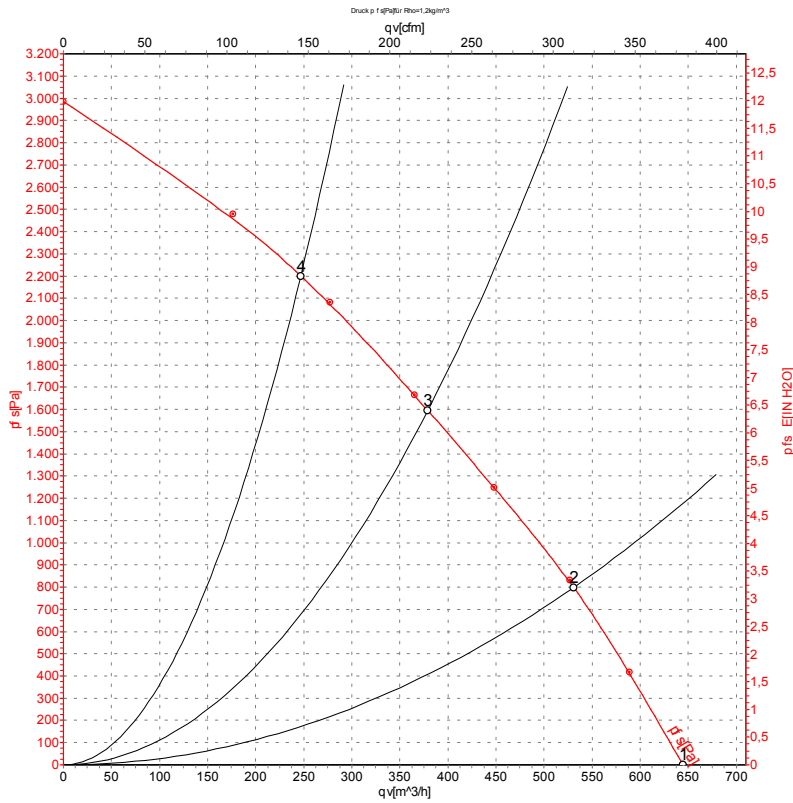

Measurement: LU-48240

Air performance measured as per ISO 5801 Installation category A. For detailed information on the measuring set-up, please contact ebm-papst. Suction-side noise levels: L_{wA} measured as per ISO 13347 / L_{pA} measured with 1m distance to fan axis. The values given are valid under the measuring conditions mentioned above and may vary according to the actual installation situation. With any deviation from the standard set-up, the specific values have to be checked and reviewed with the unit installed.

Measured values

	U	f	n	P _{ed}	I	qv	p _{fs}
	V	Hz	min ⁻¹	W	A	m ³ /h	Pa
1	230	50	5650	315	2.15	645	0
2	230	50	5740	315	2.15	530	800
3	230	50	5940	300	2.08	380	1600
4	230	50	6215	273	1.88	245	2200

U = Supply voltage · f = Frequency · n = Speed · P_{ed} = Power input · I = Current draw · qv = Air flow · p_{fs} = Pressure increase

