

D4E240-BA01-01

AC centrifugal fan

forward-curved, dual-intake

with housing (flange)

ebm-papst Mulfingen GmbH & Co. KG

Bachmühle 2 · D-74673 Mulfingen

Phone +49 7938 81-0

Fax +49 7938 81-110

sales@fansco.com

www.fansco.com

Limited partnership · Headquarters Mulfingen

Amtsgericht (court of registration) Stuttgart · HRA 590344

General partner Elektrobau Mulfingen GmbH · Headquarters Mulfingen

Amtsgericht (court of registration) Stuttgart · HRB 590142

Nominal data

Type	D4E240-BA01-01		
Motor	M4E094-IF		
Phase		1~	1~
Nominal voltage	VAC	230	230
Frequency	Hz	50	60
Method of obtaining data		fa	ml
Valid for approval/standard		-	-
Speed (rpm)	min ⁻¹	1300	1310
Power consumption	W	1020	1320
Current draw	A	4.45	5.75
Capacitor	µF	25	25
Capacitor voltage	VDB	400	450
Capacitor standard		S2 (CE)	S2 (CE)
Min. back pressure	Pa	0	50
Min. back pressure	in. wg	0	0.2
Min. ambient temperature	°C	-40	-40
Max. ambient temperature	°C	70	55
Starting current	A	8.3	7.5

ml = Max. load · me = Max. efficiency · fa = Free air · cs = Customer specification · ce = Customer equipment
Subject to change



AC centrifugal fan

forward-curved, dual-intake

with housing (flange)

Technical description

Weight	14.8 kg
Fan size	240 mm
Impeller material	Sheet steel, galvanized
Housing material	Sheet steel, galvanized
Motor suspension	Motor vibration-damped on both sides
Direction of rotation	Clockwise, viewed toward rotor
Degree of protection	IP10
Insulation class	"F"
Moisture (F) / Environmental (H) protection class	F0
Ambient temperature note	Occasional start-up between -40°C and -25°C is permissible. For continuous operation at temperatures below -25°C (e.g. refrigeration applications) we recommend our fan design with special low-temperature bearings.
Max. permitted ambient temp. for motor (transport/storage)	+80 °C
Min. permitted ambient temp. for motor (transport/storage)	-40 °C
Installation position	Any
Condensation drainage holes	None
Mode	S1
Motor bearing	Ball bearing
Touch current according to IEC 60990 (measuring circuit Fig. 4, TN system)	<= 3.5 mA
Motor protection	Thermal overload protector (TOP) with basic insulation
With cable	Axial
Protection class	I (with customer connection of protective earth)
Motor capacitor according to EN 60252-1 in safety protection class	S2
Conformity with standards	EN 60034-1 (2010)
Approval	CCC; EAC



AC centrifugal fan

forward-curved, dual-intake
with housing (flange)

Product drawing

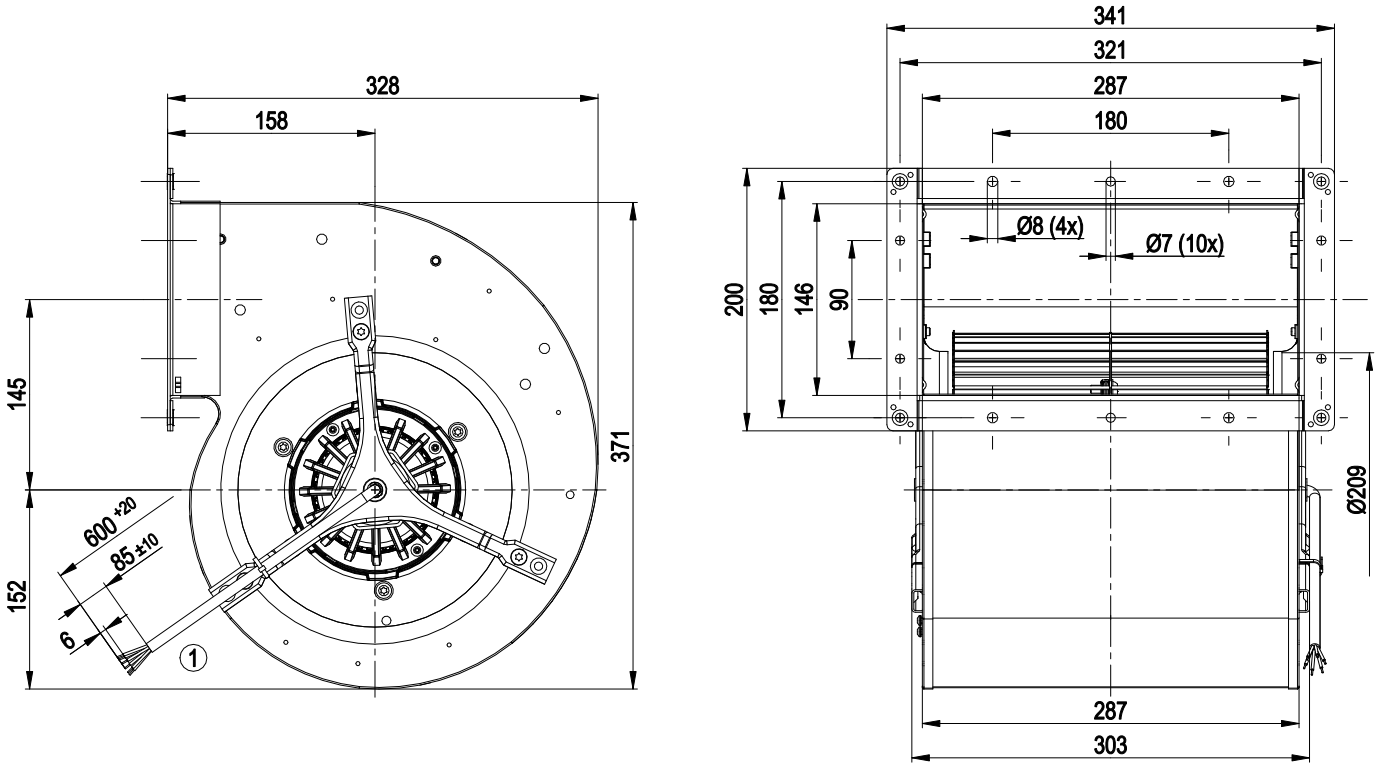

1 Cable ETFE AWG18, 6x crimped splices

Connection diagram

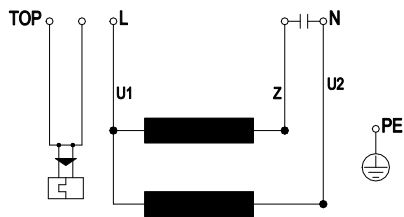

TOP	2x gray	U1	blue	Z	brown
U2	black	PE	green/yellow		



AC centrifugal fan

forward-curved, dual-intake

with housing (flange)

Curves: Air performance 50 Hz

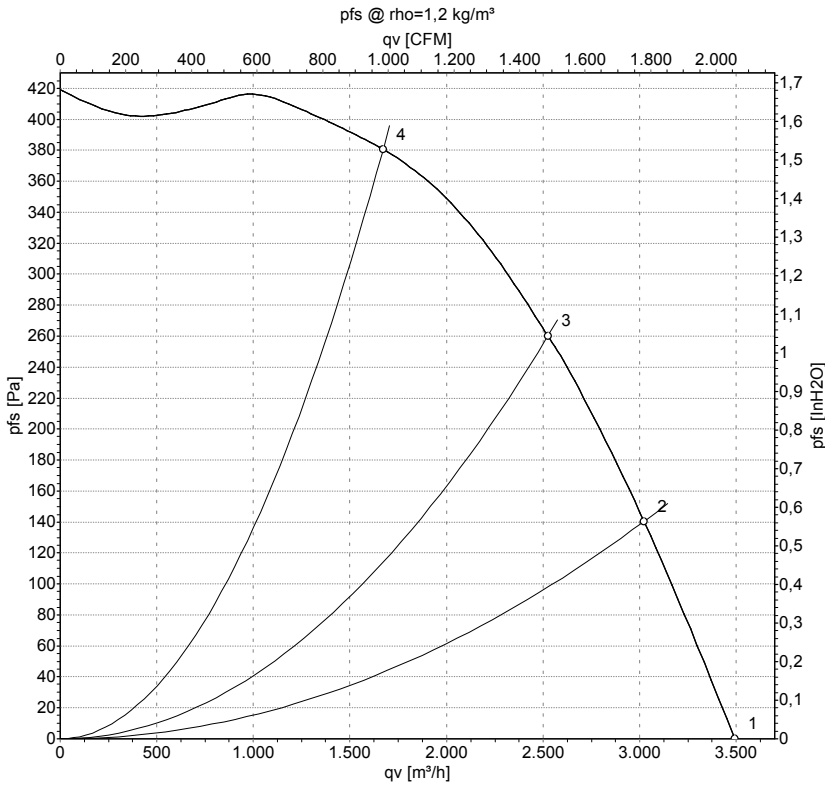

Measurement: LU-66809-1

Air performance measured according to ISO 5801 installation category A. For detailed information on the measurement setup, contact ebm-papst. Intake sound level: Sound power level according to ISO 13347 / sound pressure level measured at 1 m distance from fan axis. The values given are valid under the specified measuring conditions and may vary due to conditions of installation. For deviations from the standard configuration, the parameters have to be checked on the installed unit.

Measured values

	U	f	n	P _e	I	q _v	p _{fs}	q _v	p _{fs}
	V	Hz	min ⁻¹	W	A	m ³ /h	Pa	cfm	in. wg
1	230	50	1300	1020	4.45	3495	0	2055	0.00
2	230	50	1340	868	3.82	3025	140	1780	0.56
3	230	50	1375	749	3.33	2525	260	1485	1.04
4	230	50	1420	584	2.67	1670	380	985	1.53

U = Power supply · f = Frequency · n = Speed (rpm) · P_e = Power consumption · I = Current draw · q_v = Air flow · p_{fs} = Pressure increase



AC centrifugal fan

forward-curved, dual-intake

with housing (flange)

Curves: Air performance 60 Hz

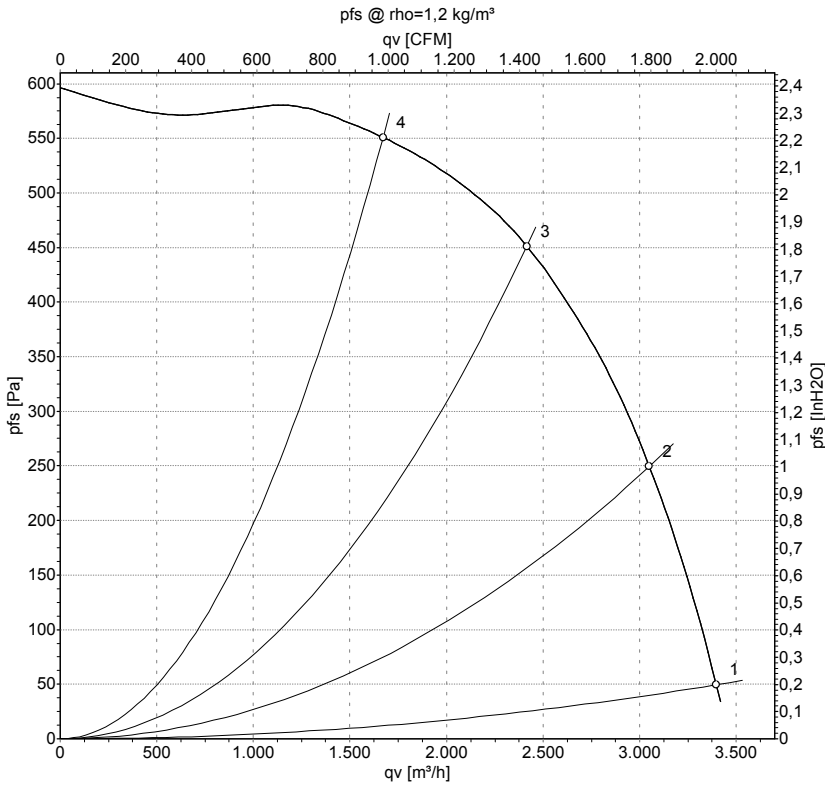

Measurement: LU-66810-1

Air performance measured according to ISO 5801 installation category A. For detailed information on the measurement setup, contact ebm-papst. Intake sound level: Sound power level according to ISO 13347 / sound pressure level measured at 1 m distance from fan axis. The values given are valid under the specified measuring conditions and may vary due to conditions of installation. For deviations from the standard configuration, the parameters have to be checked on the installed unit.

Measured values

	U	f	n	P _e	I	q _v	P _{fs}	q _v	P _{fs}
	V	Hz	min ⁻¹	W	A	m ³ /h	Pa	cfm	in. wg
1	230	60	1310	1320	5.75	3400	50	2000	0.20
2	230	60	1490	1176	5.14	3050	250	1795	1.00
3	230	60	1600	1022	4.57	2415	450	1425	1.81
4	230	60	1665	874	4.08	1670	550	985	2.21

U = Power supply · f = Frequency · n = Speed (rpm) · P_e = Power consumption · I = Current draw · q_v = Air flow · P_{fs} = Pressure increase

