

EC centrifugal fan

forward-curved, dual-intake

with housing (flange)

ebm-papst Mulfingen GmbH & Co. KG

Bachmühle 2 · D-74673 Mulfingen

Phone +49 7938 81-0

Fax +49 7938 81-110

sales@fansco.com

www.fansco.com

Limited partnership · Headquarters Mulfingen

Amtsgericht (court of registration) Stuttgart · HRA 590344

General partner Elektrobau Mulfingen GmbH · Headquarters Mulfingen

Amtsgericht (court of registration) Stuttgart · HRB 590142

Nominal data

Type	D3G225-IF11-02	
Motor	M3G084-GF	
Phase		1~
Nominal voltage	VAC	230
Nominal voltage range	VAC	200 .. 277
Frequency	Hz	50/60
Method of obtaining data		fa
Speed (rpm)	min ⁻¹	1430
Power consumption	W	750
Current draw	A	3.3
Min. back pressure	Pa	150
Min. back pressure	in. wg	0.6
Min. ambient temperature	°C	-25
Max. ambient temperature	°C	40

ml = Max. load · me = Max. efficiency · fa = Free air · cs = Customer specification · ce = Customer equipment
Subject to change

Data according to Commission Regulation (EU) 327/2011 (EN 17166)

		Actual	Req. 2015			
01 Overall efficiency η_{es}	%	51.1	36.3	09 Power consumption P_{ed}	kW	0.6
02 Measurement category		A		09 Air flow q_v	m ³ /h	2005
03 Efficiency category		Static		09 Pressure increase p_{fs}	Pa	503
04 Efficiency grade N		58.8	44	10 Speed (rpm) n	min ⁻¹	1765
05 Variable speed drive		Yes		11 Specific ratio*		1.01

Data obtained at optimum efficiency level.

The ErP data is determined using a motor-impeller combination in a standardized measurement setup.

* Specific ratio = $1 + p_{fs} / 100\,000\text{ Pa}$

LU-180552



Technical description

Weight	12.5 kg
Size	225 mm
Motor size	84
Rotor surface	Painted black
Impeller material	Sheet steel, galvanized
Housing material	Sheet steel, galvanized
Motor suspension	Motor mounted on brackets for one-sided vibration damping
Direction of rotation	Counterclockwise, viewed toward rotor
Degree of protection	IP54
Insulation class	"F"
Moisture (F) / Environmental (H) protection class	H1
Max. permitted ambient temp. for motor (transport/storage)	+85 °C
Min. permitted ambient temp. for motor (transport/storage)	-40 °C
Installation position	Shaft horizontal
Condensation drainage holes	On rotor side
Mode	S1
Motor bearing	Ball bearing
Technical features	<ul style="list-style-type: none"> - Output 10 VDC, max. 10 mA - Operation and alarm display - Tach output - Alarm relay - Integrated PID controller - Power limiter - Motor current limitation - PFC, active - RS-485 MODBUS-RTU - Soft start - Control input 0-10 VDC / PWM - Control interface with SELV potential safely disconnected from the mains - Thermal overload protection for electronics/motor - Line undervoltage / phase failure detection
EMC immunity to interference	According to EN 61000-6-2 (industrial environment)
EMC circuit feedback	According to EN 61000-3-2/3
EMC interference emission	According to EN 61000-6-3 (household environment)
Touch current according to IEC 60990 (measuring circuit Fig. 4, TN system)	<= 3.5 mA
Electrical hookup	Terminal strip
Motor protection	Thermal overload protector (TOP) internally connected
With cable	Variable
Pollution degree	2
Protection class	I (with customer connection of protective earth)
Conformity with standards	EN 60335-1; EN 61800-5-1; CE
Approval	EAC

EC centrifugal fan

forward-curved, dual-intake

with housing (flange)

Product drawing

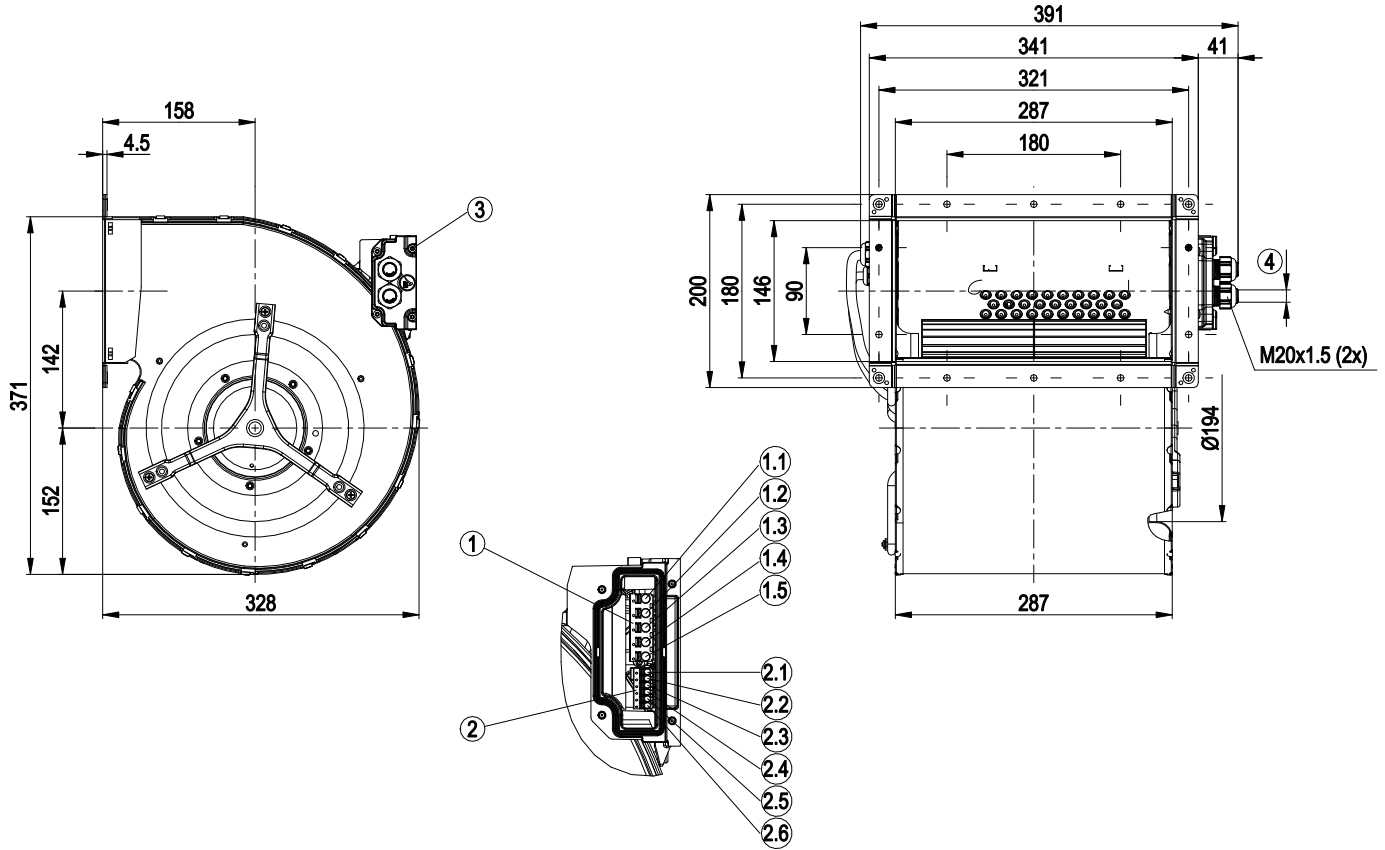

1	Terminal 1
1.1	PE
1.2	L
1.3	N
1.4	NC
1.5	COM
2	Terminal 2
2.1	0-10 V
2.2	+10 V
2.3	GND
2.4	RSA
2.5	RSB
2.6	Tach
3	Tightening torque 3 ± 0.5 Nm
4	Cable diameter min. 6 mm, max. 10 mm, tightening torque 1.8 ± 0.3 Nm Cable diameter min. 8 mm, max. 12 mm, tightening torque 1.8 ± 0.3 Nm (use must be made of seal provided)



EC centrifugal fan

forward-curved, dual-intake

with housing (flange)

Connection diagram

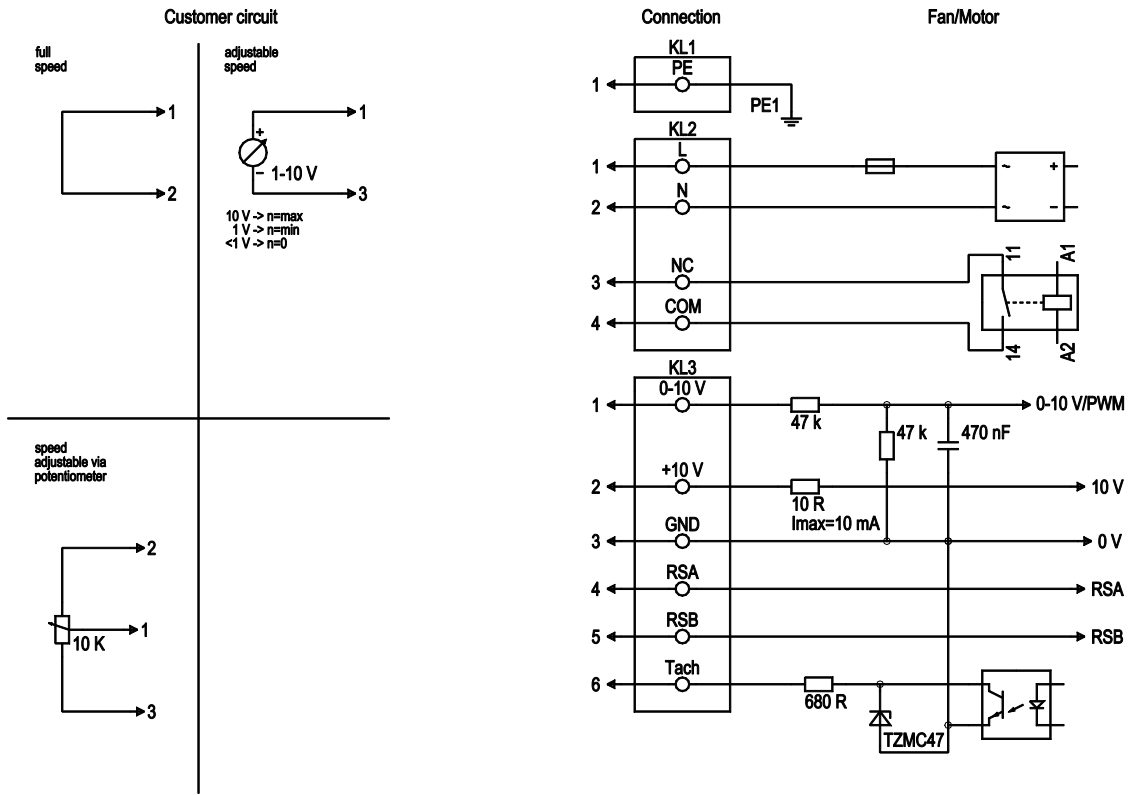

No.	Conn.	Designation	Function/assignment
KL1	1	PE	Protective earth
KL2	2	L	Power supply, phase, 50/60 Hz
KL2	3	N	Power supply, neutral conductor, 50/60 Hz
KL2	4	NC	Status relay, floating status contact, break for failure, contact rating 250 VAC/2 A (AC1) min. 10 mA, basic insulation on supply side and reinforced insulation on control interface side
KL2	5	COM	Status relay, floating status contact, common connection, contact rating 250 VAC / 2 A (AC1) / min. 10 mA; basic insulation on supply side and reinforced insulation on control interface side
KL3	1	0-10 V	Analog input (set value), 0-10 V, R _i = 100 kΩ, adjustable curve, SELV
KL3	2	+10 V	Fixed voltage output 10 VDC, SELV
KL3	3	GND	Reference ground for control interface, SELV
KL3	4	RSA	RS485 interface for MODBUS, RSA; SELV
KL3	5	RSB	RS485 interface for MODBUS, RSB; SELV
KL3	6	Tacho	Tach output, open collector, 1 pulse per revolution, I _{sink} max = 10 mA, SELV



EC centrifugal fan

forward-curved, dual-intake

with housing (flange)

Curves: Air performance 50 Hz

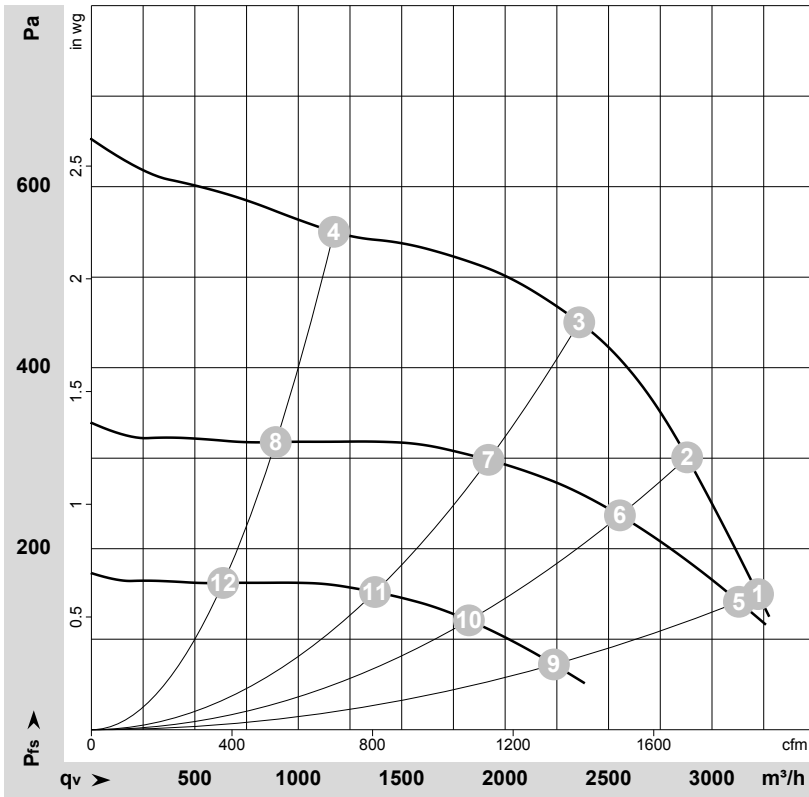

$\rho = 1.15 \text{ kg/m}^3 \pm 2 \%$

Measurement: LU-180552-1

Air performance measured according to ISO 5801 installation category A. For detailed information on the measurement setup, contact ebmpapst. Intake sound level: Sound power level according to ISO 13347 / sound pressure level measured at 1 m distance from fan axis. The values given are valid under the specified measuring conditions and may vary due to conditions of installation. For deviations from the standard configuration, the parameters have to be checked on the installed unit.

Measured values

	U	f	n	P _{ed}	I	LpA _{in}	LwA _{in}	q _v	P _{fs}	q _v	P _{fs}
	V	Hz	min ⁻¹	W	A	dB(A)	dB(A)	m ³ /h	Pa	cfm	in. wg
1	230	50	1430	750	3.30	70	83	3225	150	1895	0.60
2	230	50	1575	750	3.29	69	82	2880	300	1695	1.20
3	230	50	1720	691	3.03	67	80	2360	450	1390	1.81
4	230	50	1840	431	1.92	67	79	1170	550	690	2.21
5	230	50	1400	700	3.07			3130	142	1840	0.57
6	230	50	1400	528	2.31			2555	237	1505	0.95
7	230	50	1400	373	1.64			1920	298	1130	1.20
8	230	50	1400	189	0.85			890	318	525	1.28
9	230	50	1000	255	1.12			2235	73	1315	0.29
10	230	50	1000	193	0.84			1825	121	1075	0.49
11	230	50	1000	136	0.60			1370	152	805	0.61
12	230	50	1000	69	0.31			635	162	375	0.65

U = Voltage · f = Frequency · n = Speed (rpm) · P_{ed} = Power consumption · I = Current draw · LpA_{in} = Sound pressure level intake side · LwA_{in} = Sound power level intake side
 q_v = Air flow · P_{fs} = Pressure increase

