

D2E133-DM47-A3

# AC centrifugal fan

forward-curved

with housing (without flange)

## ebm-papst Mulfingen GmbH & Co. KG

Bachmühle 2 · D-74673 Mulfingen

Phone +49 7938 81-0

Fax +49 7938 81-110

sales@fansco.com

www.fansco.com

Limited partnership · Headquarters Mulfingen

Amtsgericht (court of registration) Stuttgart · HRA 590344

General partner Elektrobau Mulfingen GmbH · Headquarters Mulfingen

Amtsgericht (court of registration) Stuttgart · HRB 590142

## Nominal data

Type	D2E133-DM47-A3		
Motor	M2E068-DF		
Phase		1~	1~
Nominal voltage	VAC	230	230
Frequency	Hz	50	60
Method of obtaining data		fa	fa
Valid for approval/standard		-	-
Speed (rpm)	min <sup>-1</sup>	1150	1550
Power consumption	W	190	195
Current draw	A	0.84	0.85
Capacitor	µF	3	3
Capacitor voltage	VDB	450	450
Capacitor standard		S0 (CE)	S0 (CE)
Min. back pressure	Pa	0	100
Min. back pressure	in. wg	0	0.4
Min. ambient temperature	°C	-25	-25
Max. ambient temperature	°C	30	30

ml = Max. load · me = Max. efficiency · fa = Free air · cs = Customer specification · ce = Customer equipment  
Subject to change



# AC centrifugal fan

forward-curved

with housing (without flange)

## Technical description

<b>Weight</b>	4 kg
<b>Fan size</b>	133 mm
<b>Rotor surface</b>	Unpainted
<b>Impeller material</b>	Sheet steel, galvanized
<b>Housing material</b>	Sheet steel, galvanized
<b>Guard grille material</b>	Steel, coated with gray plastic (RAL 9006)
<b>Motor suspension</b>	Motor mounted with brackets on one side
<b>Direction of rotation</b>	Clockwise, viewed toward rotor
<b>Degree of protection</b>	IP44; installation- and position-dependent
<b>Insulation class</b>	"B"
<b>Moisture (F) / Environmental (H) protection class</b>	H0 - dry environment
<b>Max. permitted ambient temp. for motor (transport/storage)</b>	+ 80 °C
<b>Min. permitted ambient temp. for motor (transport/storage)</b>	- 40 °C
<b>Installation position</b>	Any
<b>Condensation drainage holes</b>	None
<b>Mode</b>	S1
<b>Motor bearing</b>	Ball bearing
<b>Touch current according to IEC 60990 (measuring circuit Fig. 4, TN system)</b>	< 0.75 mA
<b>Motor protection</b>	Thermal overload protector (TOP) internally connected
<b>With cable</b>	Axial
<b>Protection class</b>	I (with customer connection of protective earth)
<b>Conformity with standards</b>	EN 60335-1



# AC centrifugal fan

forward-curved  
with housing (without flange)

## Product drawing

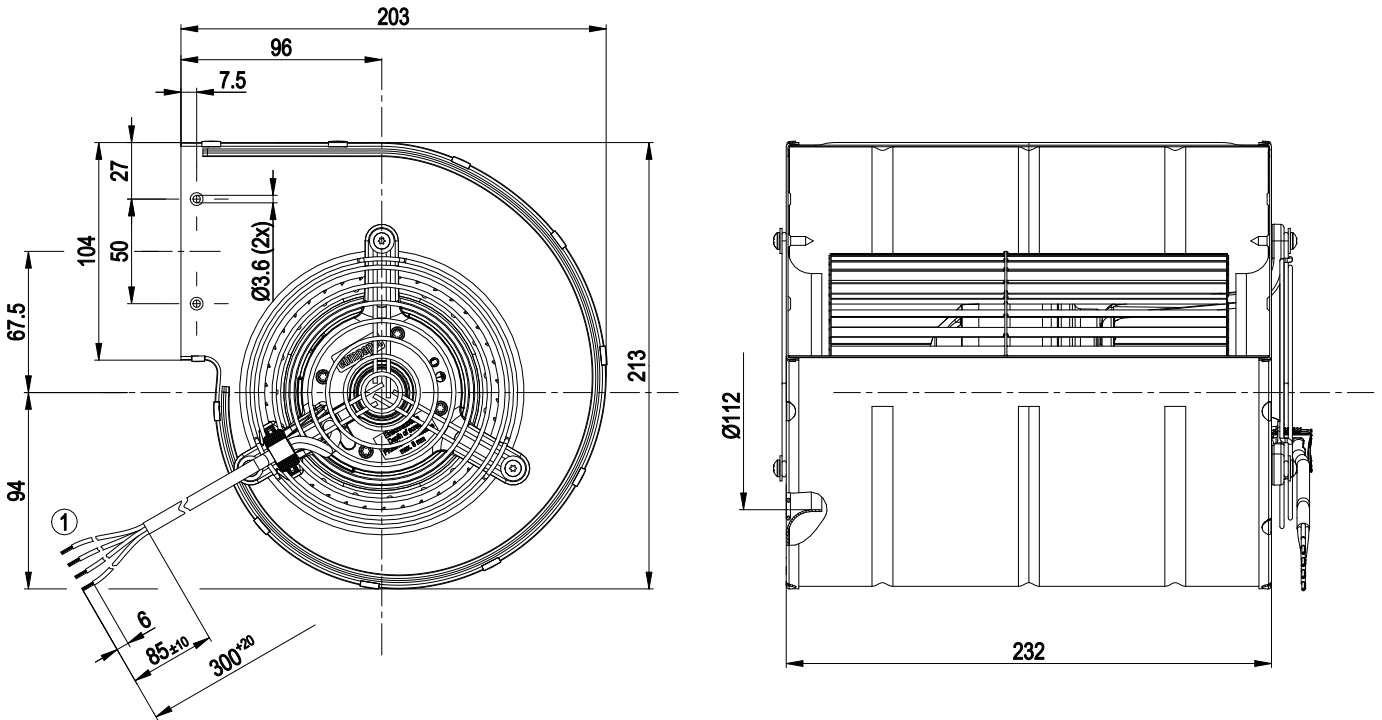

1 Cable PVC 4G 0.5 mm<sup>2</sup>, 4x crimped splices

## Connection diagram

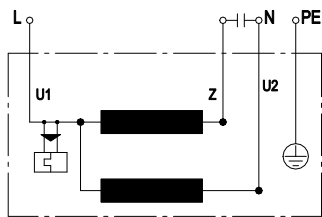

U1	blue	Z	brown	U2	black
PE	green/yellow				



## Curves: Air performance 50 Hz

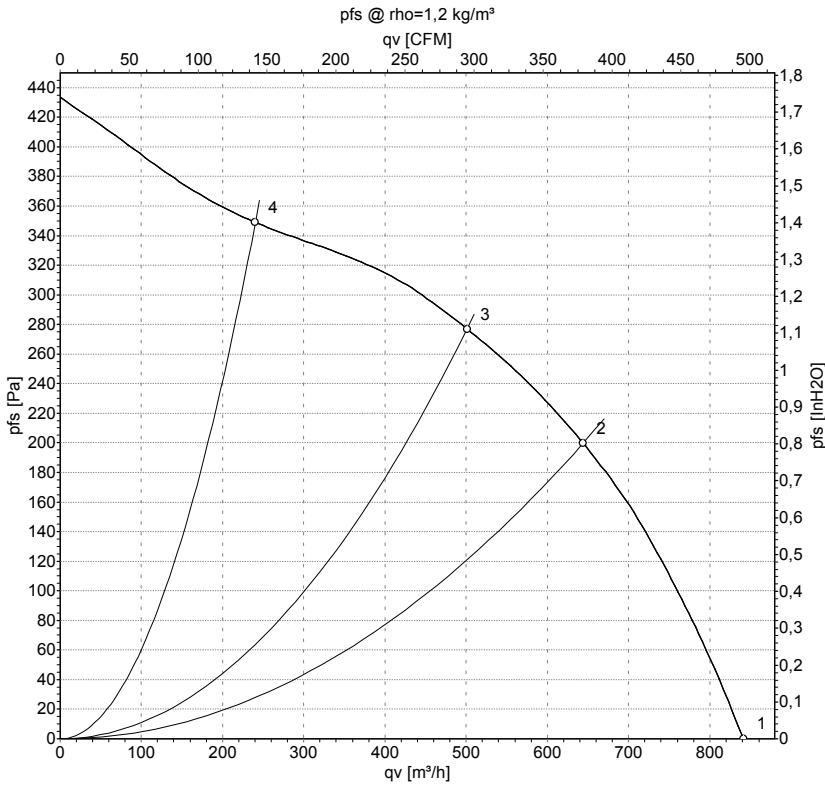

Measurement: LU-105266-1

Air performance measured according to ISO 5801 installation category A. For detailed information on the measurement setup, contact ebm-papst. Intake sound level: Sound power level according to ISO 13347 / sound pressure level measured at 1 m distance from fan axis. The values given are valid under the specified measuring conditions and may vary due to conditions of installation. For deviations from the standard configuration, the parameters have to be checked on the installed unit.

## Measured values

	U	f	n	P <sub>e</sub>	I	q <sub>v</sub>	p <sub>fs</sub>	q <sub>v</sub>	p <sub>fs</sub>
	V	Hz	min <sup>-1</sup>	W	A	m <sup>3</sup> /h	Pa	cfm	in. wg
1	230	50	1150	190	0.84	840	0	495	0.00
2	230	50	1980	162	0.70	645	200	380	0.80
3	230	50	2275	146	0.63	500	275	295	1.10
4	230	50	2530	125	0.54	240	350	140	1.41

U = Power supply · f = Frequency · n = Speed (rpm) · P<sub>e</sub> = Power consumption · I = Current draw · q<sub>v</sub> = Air flow · p<sub>fs</sub> = Pressure increase



## Curves: Air performance 60 Hz

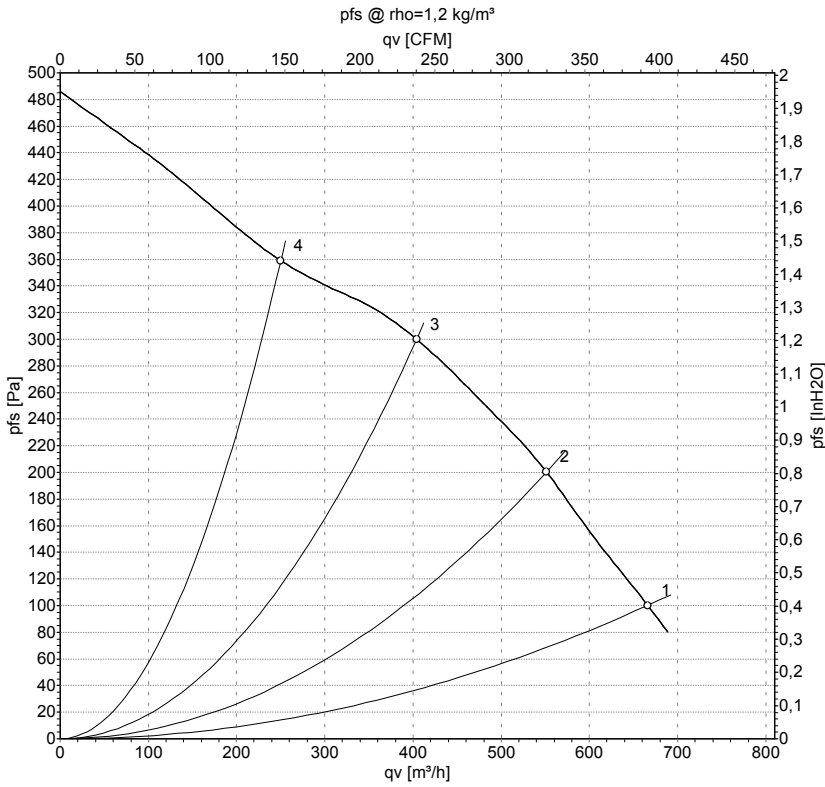

Measurement: LU-105267-1

Air performance measured according to ISO 5801 installation category A. For detailed information on the measurement setup, contact ebm-papst. Intake sound level: Sound power level according to ISO 13347 / sound pressure level measured at 1 m distance from fan axis. The values given are valid under the specified measuring conditions and may vary due to conditions of installation. For deviations from the standard configuration, the parameters have to be checked on the installed unit.

## Measured values

	U	f	n	P <sub>e</sub>	I	q <sub>v</sub>	p <sub>fs</sub>	q <sub>v</sub>	p <sub>fs</sub>
	V	Hz	min <sup>-1</sup>	W	A	m <sup>3</sup> /h	Pa	cfm	in. wg
1	230	60	1550	195	0.85	665	100	390	0.40
2	230	60	1960	188	0.82	550	200	325	0.80
3	230	60	2355	181	0.78	405	300	240	1.20
4	230	60	2575	174	0.76	250	360	145	1.45

U = Power supply · f = Frequency · n = Speed (rpm) · P<sub>e</sub> = Power consumption · I = Current draw · q<sub>v</sub> = Air flow · p<sub>fs</sub> = Pressure increase

