

# AC centrifugal fan

forward curved, dual inlet  
with housing (without flange)

## ebm-papst Mulfingen GmbH & Co. KG

Bachmühle 2 · D-74673 Mulfingen

Phone +49 7938 81-0

Fax +49 7938 81-110

sales@fansco.com

www.fansco.com

Limited partnership · Headquarters Mulfingen

County court Stuttgart · HRA 590344

General partner Elektrobau Mulfingen GmbH · Headquarters Mulfingen

County court Stuttgart · HRB 590142

## Nominal data

Type	D2E133-AM47-94				
Motor	M2E068-DF				
Phase		1~	1~	1~	1~
Nominal voltage	VAC	230	230	230	230
Frequency	Hz	50	50	60	60
Type of data definition		ml	fa	ml	ml
Valid for approval / standard					UL 2111
Speed	min <sup>-1</sup>	1830	1500	1800	1800
Power input	W	165	190	200	210
Current draw	A	0.73	0.84	0.88	0.92
Motor capacitor	µF	3	3	3	3
Capacitor voltage	VDB	450	450	450	450
Capacitor standard					UL
Min. back pressure	Pa	80	0	100	100
Min. ambient temperature	°C	-25	-25	-25	-25
Max. ambient temperature	°C	50	35	25	25
Starting current	A	0.9	0.9	0.9	

ml = max. load · me = max. efficiency · fa = running at free air · cs = customer specs · cu = customer unit  
Subject to alterations



# AC centrifugal fan

forward curved, dual inlet  
with housing (without flange)

## Technical features

<b>Mass</b>	3.48 kg
<b>Size</b>	133 mm
<b>Surface of rotor</b>	Partially cast in aluminium
<b>Material of impeller</b>	Sheet steel, hot-galvanised
<b>Housing material</b>	Sheet steel, hot-galvanised
<b>Motor suspension</b>	Motor mounted via brackets on one side
<b>Direction of rotation</b>	Clockwise, seen on rotor
<b>Type of protection</b>	IP 44; Depending on installation and position
<b>Insulation class</b>	"B"
<b>Humidity class</b>	F0
<b>Max. permissible ambient motor temp. (transp./ storage)</b>	+ 80 °C
<b>Min. permissible ambient motor temp. (transp./storage)</b>	- 40 °C
<b>Mounting position</b>	Any
<b>Condensate discharge holes</b>	None
<b>Operation mode</b>	S1
<b>Motor bearing</b>	Ball bearing
<b>Touch current acc. IEC 60990 (measuring network Fig. 4, TN system)</b>	< 0.75 mA
<b>Motor protection</b>	Thermal overload protector (TOP) wired internally
<b>Cable exit</b>	Axial
<b>Protection class</b>	I (if protective earth is connected by customer)
<b>Product conforming to standard</b>	EN 60335-1; CE



# AC centrifugal fan

forward curved, dual inlet  
with housing (without flange)

## Product drawing

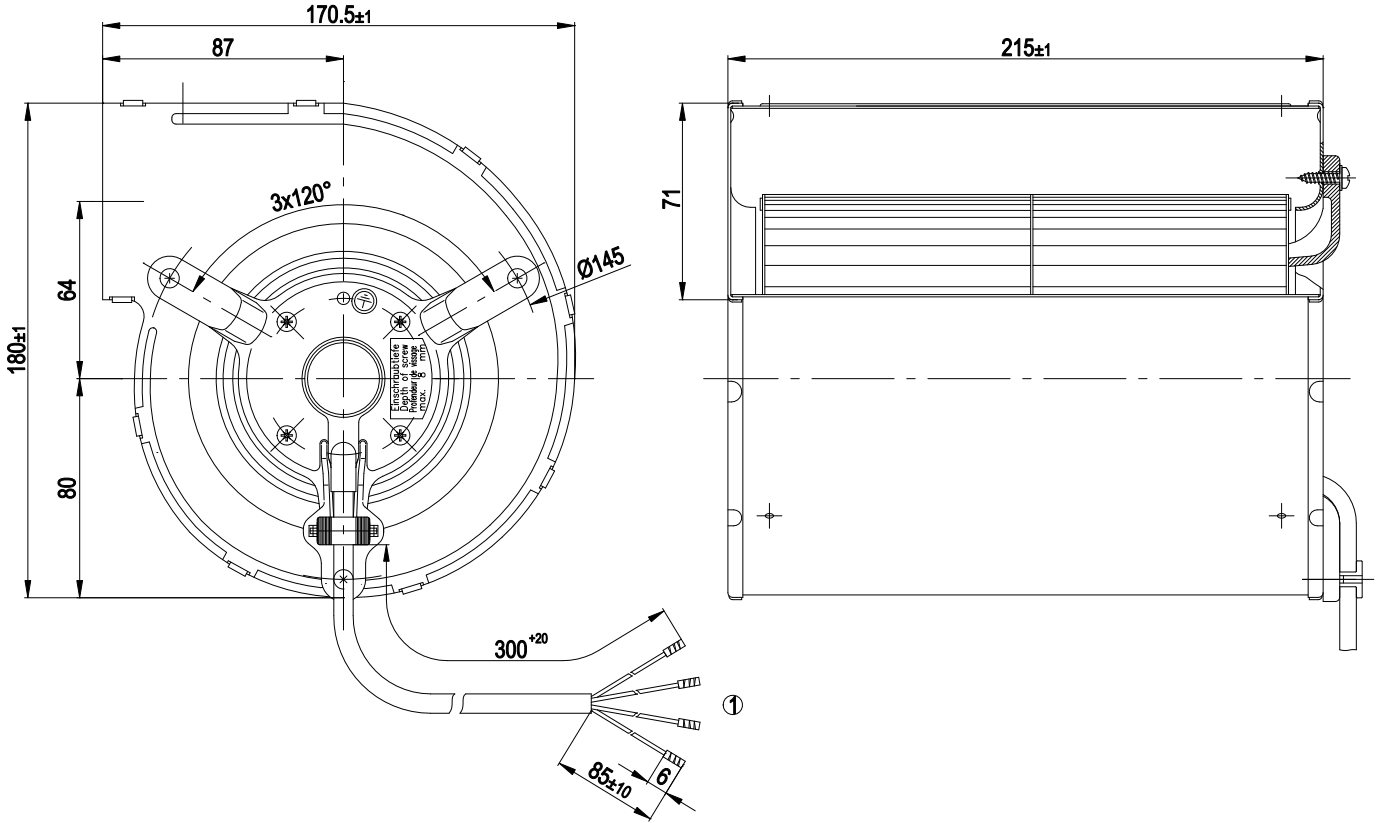

1 Connection line PVC, 4x brass lead tips crimped

## Connection screen

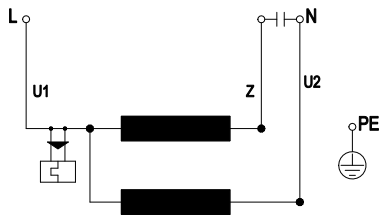

U1	blue	Z	brown	U2	black
PE	green/yellow				



# AC centrifugal fan

forward curved, dual inlet  
with housing (without flange)

## Charts: Air flow 50 Hz

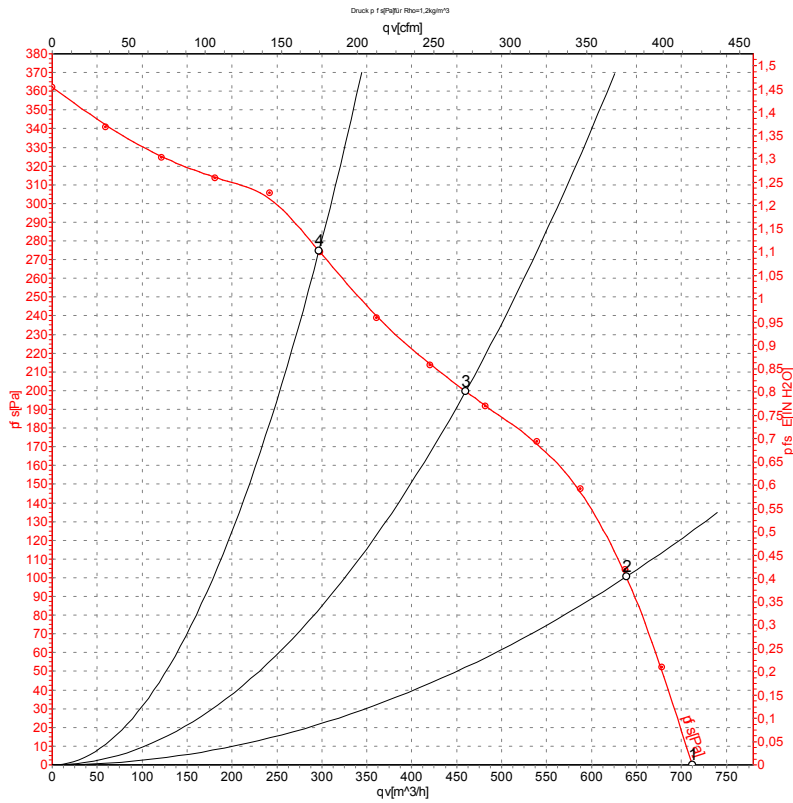

Measurement: LU-105263

Air performance measured as per ISO 5801 Installation category A. For detailed information on the measuring set-up, please contact ebmpapst. Suction-side noise levels: LwA measured as per ISO 13347 / LpA measured with 1m distance to fan axis. The values given are valid under the measuring conditions mentioned above and may vary according to the actual installation situation. With any deviation from the standard set-up, the specific values have to be checked and reviewed with the unit installed.

## Measured values

	U	f	n	P <sub>e</sub>	I	qv	P <sub>fs</sub>
	V	Hz	min <sup>-1</sup>	W	A	m <sup>3</sup> /h	Pa
1	230	50	1500	190	0.84	710	0
2	230	50	1890	164	0.72	640	100
3	230	50	2310	141	0.61	460	200
4	230	50	2570	118	0.52	295	275

U = Supply voltage · f = Frequency · n = Speed · P<sub>e</sub> = Power input · I = Current draw · qv = Air flow · P<sub>fs</sub> = Pressure increase



# AC centrifugal fan

forward curved, dual inlet  
with housing (without flange)

## Charts: Air flow 60 Hz

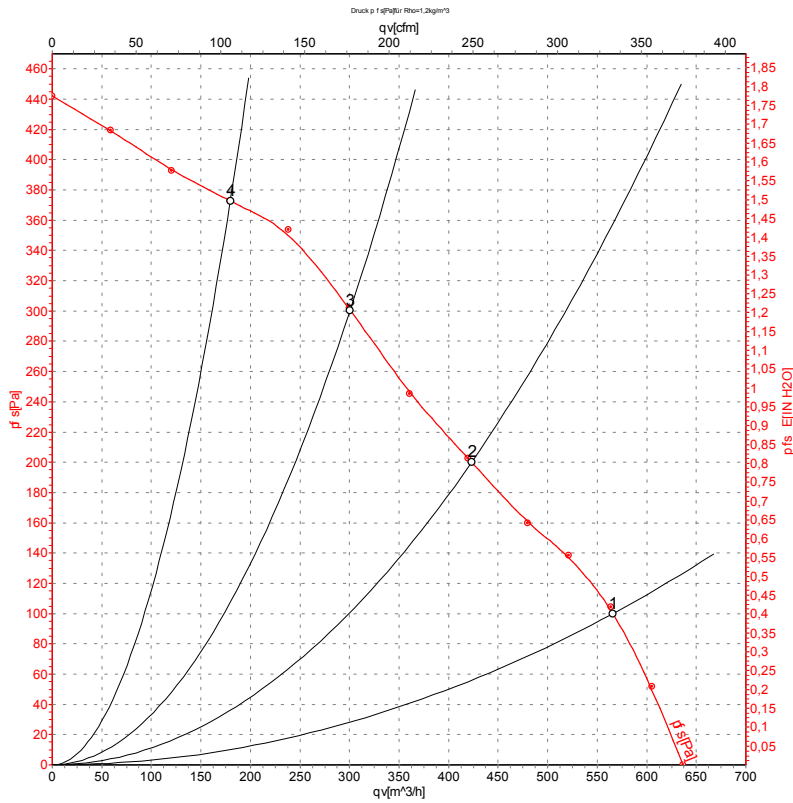

Measurement: LU-105265

Air performance measured as per ISO 5801 Installation category A. For detailed information on the measuring set-up, please contact ebm-papst. Suction-side noise levels: L<sub>wA</sub> measured as per ISO 13347 / L<sub>pA</sub> measured with 1m distance to fan axis. The values given are valid under the measuring conditions mentioned above and may vary according to the actual installation situation. With any deviation from the standard set-up, the specific values have to be checked and reviewed with the unit installed.

## Measured values

	U	f	n	P <sub>e</sub>	I	qv	P <sub>fs</sub>
	V	Hz	min <sup>-1</sup>	W	A	m <sup>3</sup> /h	Pa
1	230	60	1800	200	0.88	565	100
2	230	60	2310	181	0.78	425	200
3	230	60	2685	170	0.74	300	300
4	230	60	2945	159	0.70	180	375

U = Supply voltage · f = Frequency · n = Speed · P<sub>e</sub> = Power input · I = Current draw · qv = Air flow · P<sub>fs</sub> = Pressure increase

