

D2E097-BK80-02

AC centrifugal fan

forward-curved, dual-intake
with housing (without flange)

ebm-papst Mulfingen GmbH & Co. KG

Bachmühle 2 · D-74673 Mulfingen

Phone +49 7938 81-0

Fax +49 7938 81-110

sales@fansco.com

www.fansco.com

Limited partnership · Headquarters Mulfingen

Amtsgericht (court of registration) Stuttgart · HRA 590344

General partner Elektrobau Mulfingen GmbH · Headquarters Mulfingen

Amtsgericht (court of registration) Stuttgart · HRB 590142

Nominal data

Type	D2E097-BK80-02	
Motor	M2E052-BF	
Phase		1~
Nominal voltage	VAC	230
Frequency	Hz	50
Method of obtaining data		fa
Valid for approval/standard		CE
Speed (rpm)	min ⁻¹	1750
Power consumption	W	77
Current draw	A	0.34
Capacitor	µF	2
Capacitor voltage	VDB	400
Capacitor standard		S0 (CE)
Min. back pressure	Pa	0
Min. back pressure	in. wg	0
Min. ambient temperature	°C	-25
Max. ambient temperature	°C	30
Starting current	A	0.36

ml = Max. load · me = Max. efficiency · fa = Free air · cs = Customer specification · ce = Customer equipment
Subject to change



AC centrifugal fan

forward-curved, dual-intake
with housing (without flange)

Technical description

Weight	1.4 kg
Size	97 mm
Motor size	52
Rotor surface	Unpainted
Impeller material	Sheet steel, galvanized
Housing material	Sheet steel, galvanized
Motor suspension	Motor mounted with brackets on one side
Direction of rotation	Counterclockwise, viewed toward rotor
Degree of protection	IP20
Insulation class	"B"
Moisture (F) / Environmental (H) protection class	H0 - dry environment
Max. permitted ambient temp. for motor (transport/storage)	+ 80 °C
Min. permitted ambient temp. for motor (transport/storage)	- 40 °C
Installation position	Any
Condensation drainage holes	None
Mode	S1
Motor bearing	Ball bearing
Touch current according to IEC 60990 (measuring circuit Fig. 4, TN system)	< 0.75 mA
Motor protection	Thermal overload protector (TOP) internally connected
Protection class	I (with customer connection of protective earth)
Conformity with standards	EN 60335-1; CE



D2E097-BK80-02

AC centrifugal fan

forward-curved, dual-intake
with housing (without flange)

Product drawing

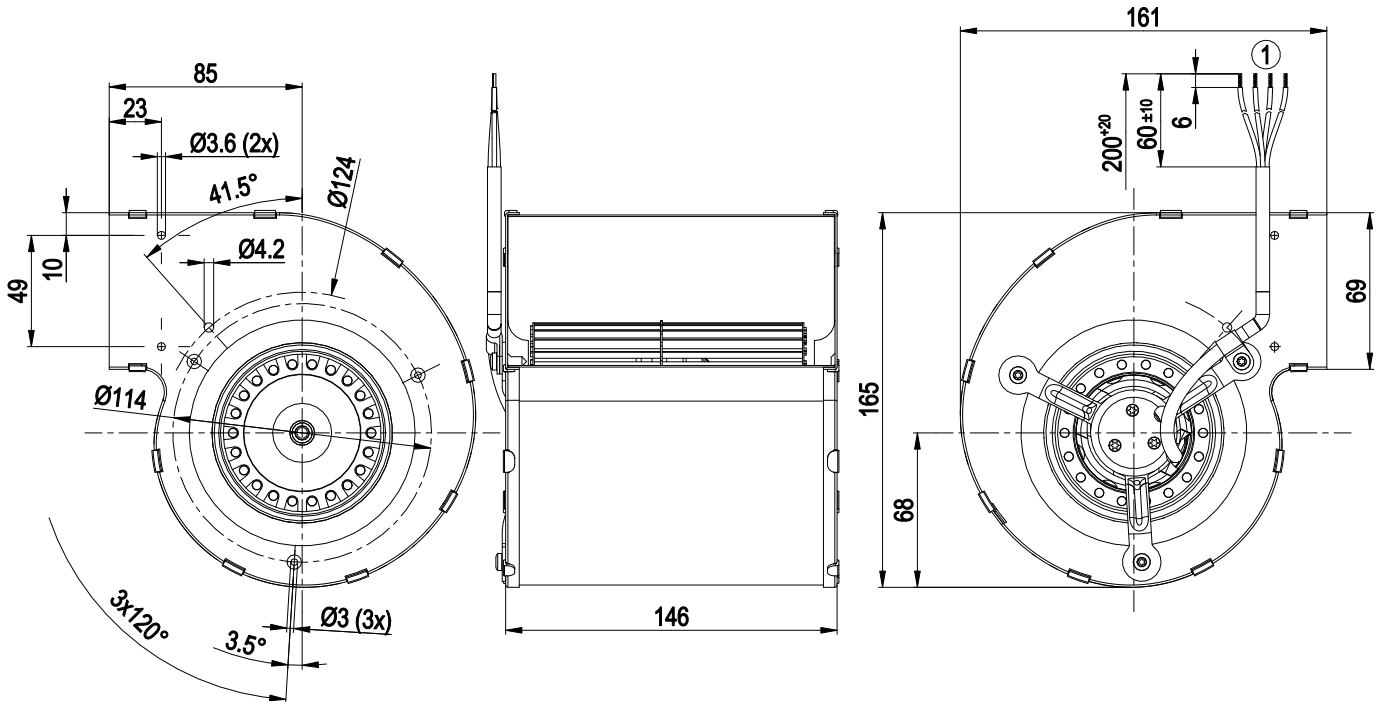

1	Cable PVC 4G 0.5 mm ²	4x splice
---	----------------------------------	-----------

Connection diagram

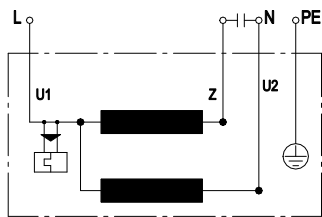

U1	blue	Z	brown	U2	black
PE	green/yellow				



AC centrifugal fan

forward-curved, dual-intake
with housing (without flange)

Curves: Air performance 50 Hz

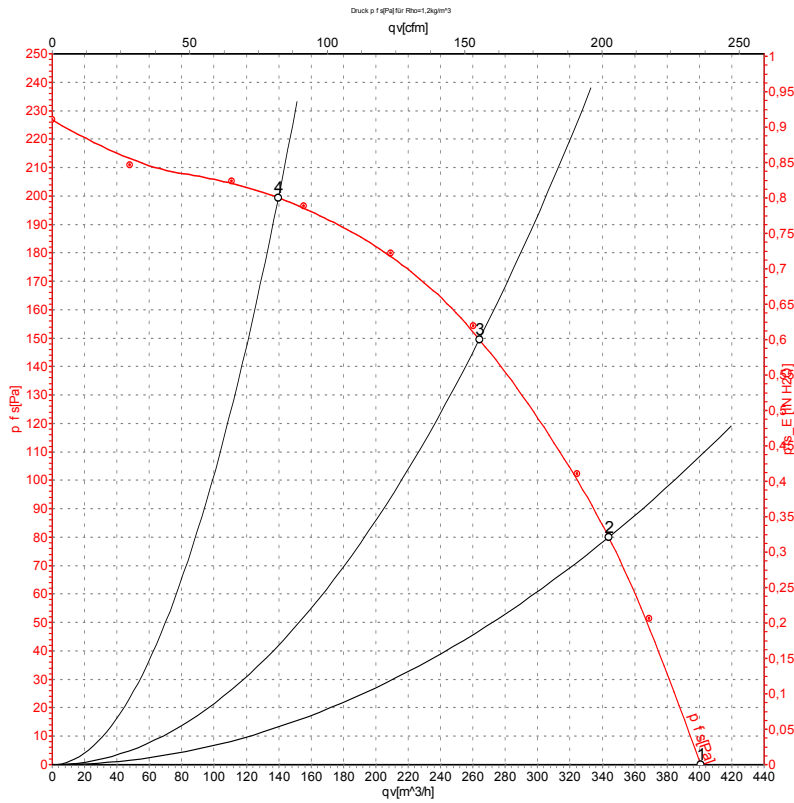

Measurement: LU-36983-1

Air performance measured according to ISO 5801 installation category A. For detailed information on the measurement setup, contact ebm-papst. Intake sound level: Sound power level according to ISO 13347 / sound pressure level measured at 1 m distance from fan axis. The values given are valid under the specified measuring conditions and may vary due to conditions of installation. For deviations from the standard configuration, the parameters have to be checked on the installed unit.

Measured values

	U	f	n	P _e	I	q _v	p _{fs}	q _v	p _{fs}
	V	Hz	min ⁻¹	W	A	m ³ /h	Pa	cfm	in. wg
1	230	50	1750	77	0.34	400	0	235	0.00
2	230	50	2070	72	0.31	345	80	200	0.32
3	230	50	2370	66	0.29	265	150	155	0.60
4	230	50	2670	63	0.28	140	200	80	0.80

U = Voltage · f = Frequency · n = Speed (rpm) · P_e = Power consumption · I = Current draw · q_v = Air flow · p_{fs} = Pressure increase



Ogni utilizzo non autorizzato di questo disegno, copia, riproduzione o invio a terzi, richiede l'esplicita approvazione da parte di ebm-papst S.r.l. - Ogni violazione sarà perseguita in sede civile e penale

Materiale	DX51D + Z200 EN 10346
Trattamento	Non verniciato
Verniciatura	Non verniciato
Note verniciatura	-
Lati verniciatura	-
Colore	
Finitura	
Peso	ca. 0.12 Kg
Spessore	1.25 mm
Profilo	
Famiglia	
Cod. casa madre	19917-2-4017

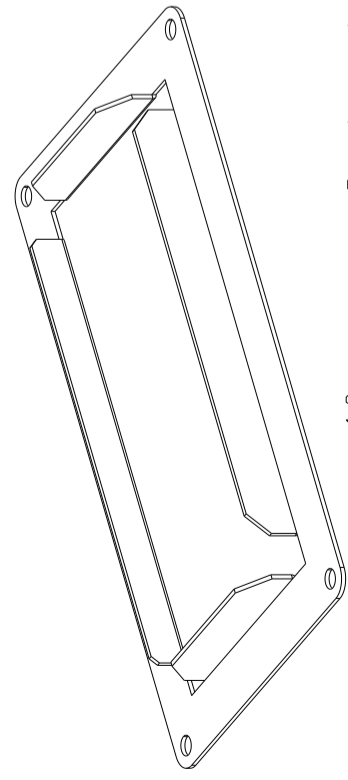
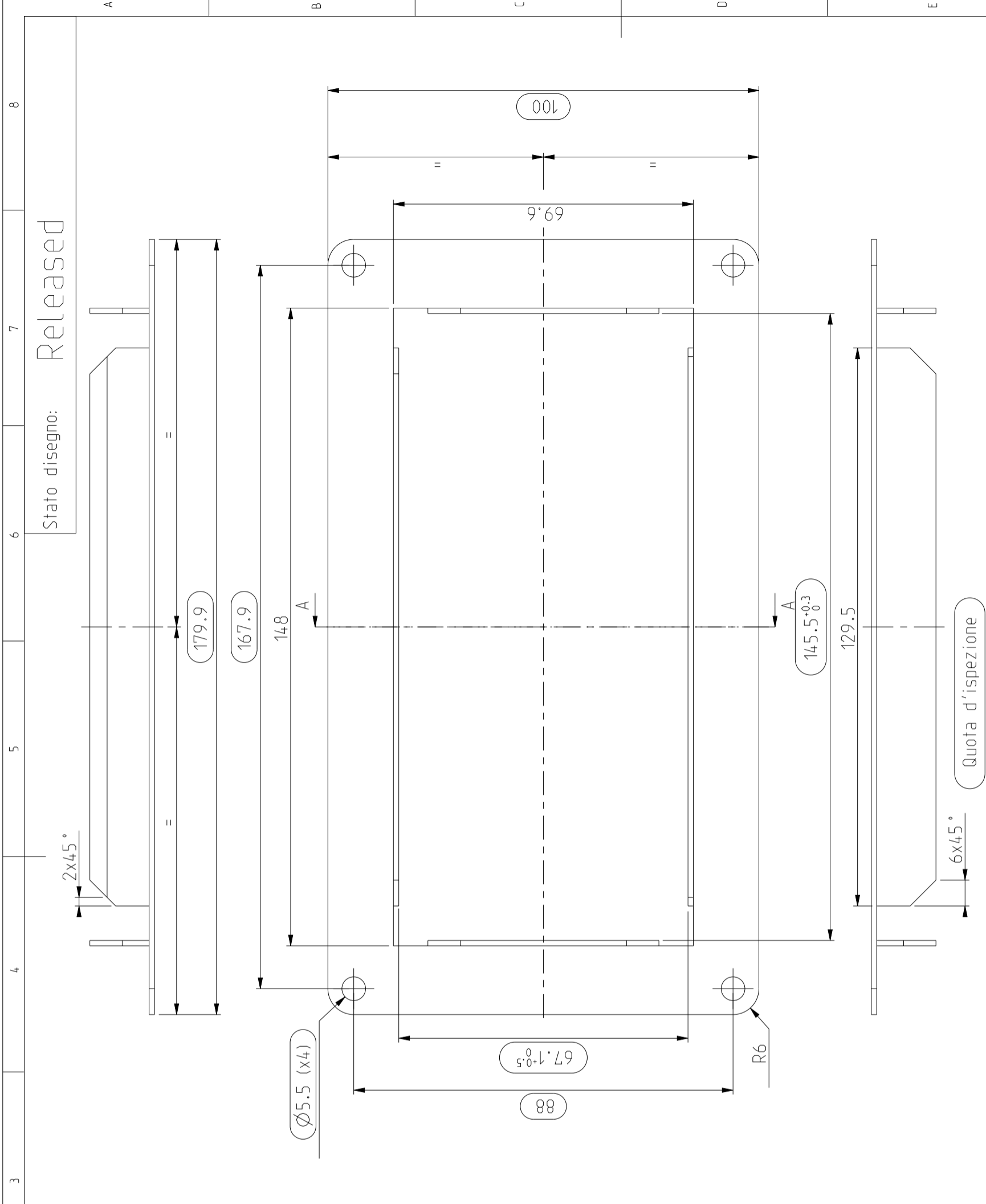

1:2 Per le quote mancanti fare riferimento al modello 3D
Le dimensioni si riferiscono al pezzo non verniciato

Quota d'ispezione

Quote senza ind. di tolleranza		ISO 2768 mK-E	
Scala		1:1	
Distribuzione Fornitore		Pubblica	
Codice		106BF0004	
Descrizione		Flangia per DZE097-B	
ebmpapst		ebm-papst S.r.l. - Via Cornaggia 108 I-22076 Mozzate (CO)	
CAD		0000011436	
Revisione		0	
Disegnato		04.06.04	
Controllo		I.Robbiani	
Stato disegno		Released	
N°		-	
Data		-	
Descrizione modifica		-	
Dis		-	
Cont		-	
Nome		-	
Data		-	
Disegnato		04.06.04	
Controllo		I.Robbiani	
Stato disegno		Released	
Foglio		1 di 1	