

ebm-papst Mulfingen GmbH & Co. KG

Bachmühle 2 · D-74673 Mulfingen

Phone +49 7938 81-0

Fax +49 7938 81-110

sales@fansco.com

www.fansco.com

Limited partnership · Headquarters Mulfingen

Amtsgericht (court of registration) Stuttgart · HRA 590344

General partner Elektrobau Mulfingen GmbH · Headquarters Mulfingen

Amtsgericht (court of registration) Stuttgart · HRB 590142

Nominal data

Type	A4D300-AS34-14					
Motor	M4D068-CF					
Phase		3~	3~	3~	3~	3~
Nominal voltage	VAC	400	400	440	460	480
Wiring		Y	Y	Y	Y	Y
Frequency	Hz	50	60	60	60	60
Method of obtaining data		ml	ml	ml	ml	ml
Valid for approval/standard		CE	CE	CE	CE	CE
Speed (rpm)	min ⁻¹	1300	1400	1460	1480	1510
Power consumption	W	68	90	100	102	105
Current draw	A	0.14	0.15	0.16	0.16	0.16
Max. back pressure	Pa	60	70	75	80	80
Max. back pressure	in. wg	0.24	0.28	0.3	0.32	0.32
Min. ambient temperature	°C	-25	-25	-25	-25	-25
Max. ambient temperature	°C	60	55	55	50	50

ml = Max. load · me = Max. efficiency · fa = Free air · cs = Customer specification · ce = Customer equipment

Subject to change



Technical description

Weight	1.65 kg
Size	300 mm
Motor size	68
Rotor surface	Painted black
Blade material	Press-fitted sheet steel blank, sprayed with PP plastic
Number of blades	5
Airflow direction	V
Direction of rotation	Counterclockwise, viewed toward rotor
Degree of protection	IP44; installation- and position-dependent as per EN 60034-5
Insulation class	"F"
Moisture (F) / Environmental (H) protection class	H1+
Max. permitted ambient temp. for motor (transport/storage)	+ 80 °C
Min. permitted ambient temp. for motor (transport/storage)	- 40 °C
Installation position	Shaft horizontal or rotor on bottom; rotor on top on request
Condensation drainage holes	On rotor side
Mode	S1
Motor bearing	Ball bearing
Touch current according to IEC 60990 (measuring circuit Fig. 4, TN system)	< 0.75 mA
With cable	Lateral
Protection class	I (with customer connection of protective earth)
Conformity with standards	EN 60335-1, motor does not have factory-installed overheating protection; CE

Product drawing

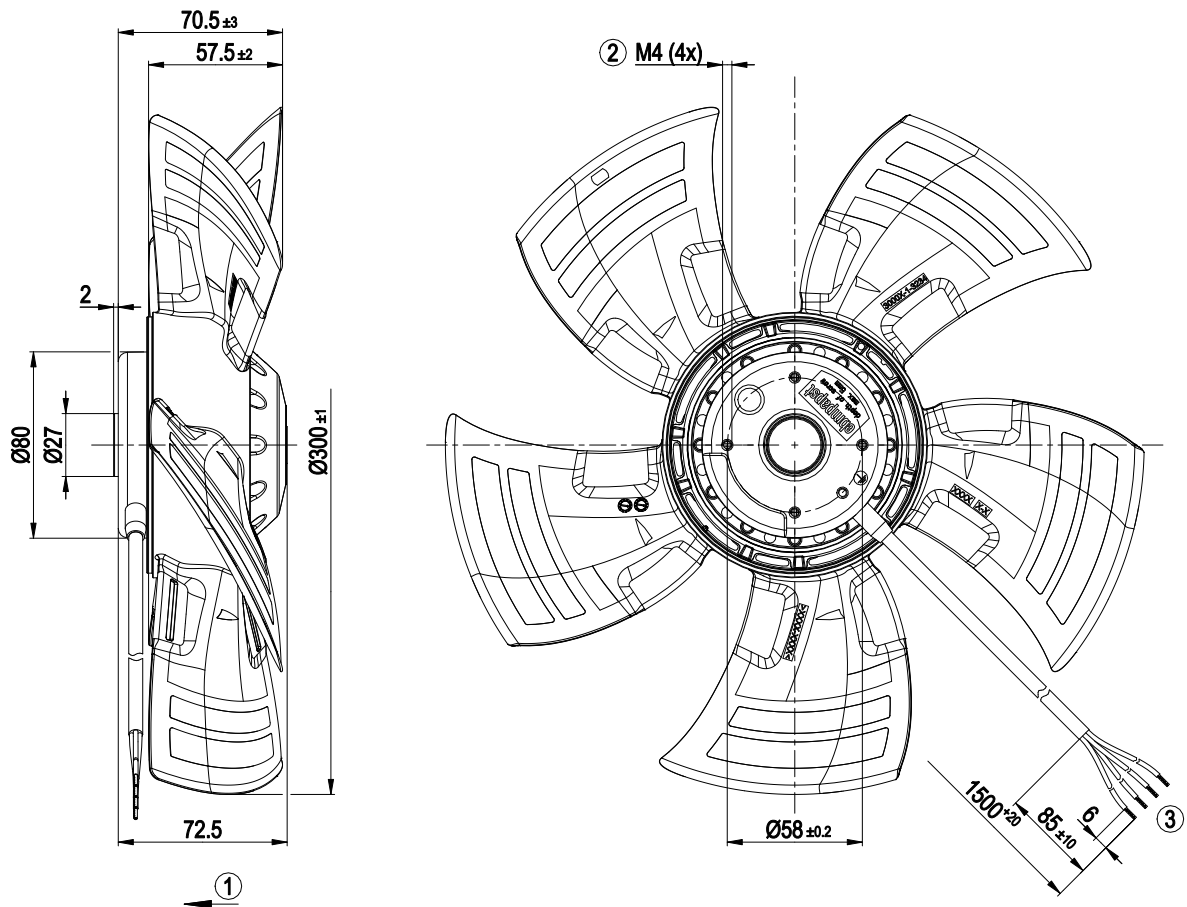

1	Airflow direction "V"
2	Max. clearance for screw 5 mm
3	Cable PVC 4G 0.5 mm ² , 4x crimped splices

Connection diagram

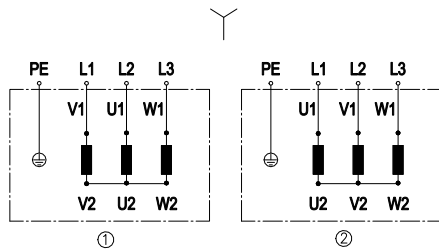

Change of rotation direction by reversing two phases

	Three-phase motor
Y	Star connection
1	Counterclockwise operation
L1	= V1 = blue
L2	= U1 = black
L3	= W1 = brown
2	Clockwise operation
L1	= U1 = black
L2	= V1 = blue
L3	= W1 = brown
PE	green/yellow

Curves: Air performance 50 Hz

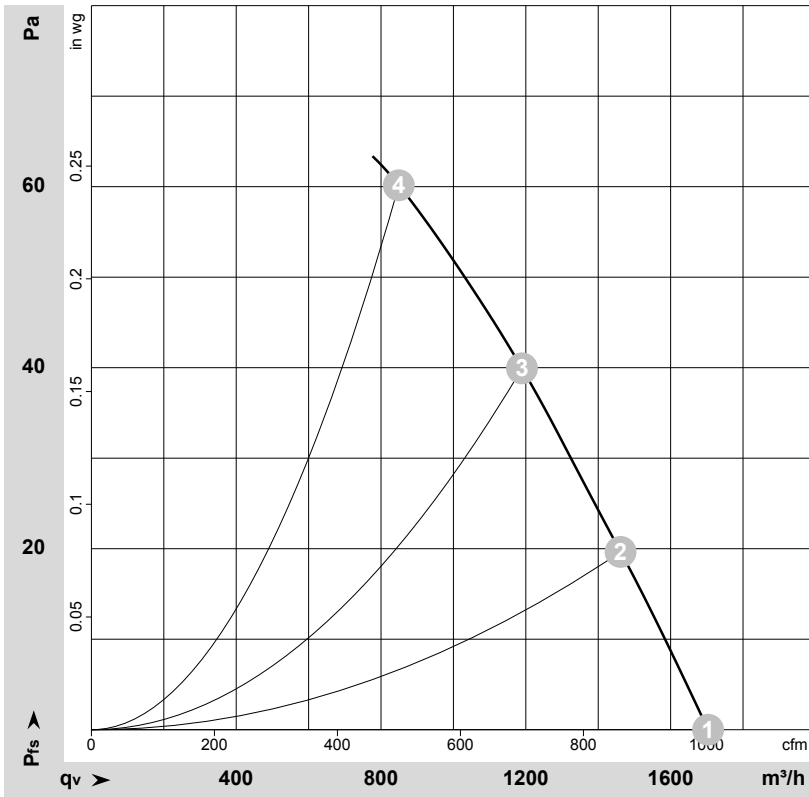

$\rho = 1.15 \text{ kg/m}^3 \pm 2 \%$

Measurement: LU-114649-1

Air performance measured according to ISO 5801 installation category A. For detailed information on the measurement setup, contact ebm-papst. Intake sound level: Sound power level according to ISO 13347 / sound pressure level measured at 1 m distance from fan axis. The values given are valid under the specified measuring conditions and may vary due to conditions of installation. For deviations from the standard configuration, the parameters have to be checked on the installed unit.

Measured values

	Wired	U	f	n	P_e	I	LpA_{in}	LwA_{in}	q_v	P_{fs}	q_v	P_{fs}
		V	Hz	min^{-1}	W	A	dB(A)	dB(A)	m^3/h	Pa	cfm	in. wg
1	Y	400	50	1370	53	0.13	52	59	1705	0	1000	0.00
2	Y	400	50	1350	57	0.13	51	58	1460	20	860	0.08
3	Y	400	50	1335	61	0.13	51	58	1190	40	700	0.16
4	Y	400	50	1300	68	0.14	57	65	850	60	500	0.24

Wired = Wiring · U = Voltage · f = Frequency · n = Speed (rpm) · P_e = Power consumption · I = Current draw · LpA_{in} = Sound pressure level intake side · LwA_{in} = Sound power level intake side
 q_v = Air flow · P_{fs} = Pressure increase



Curves: Air performance 60 Hz

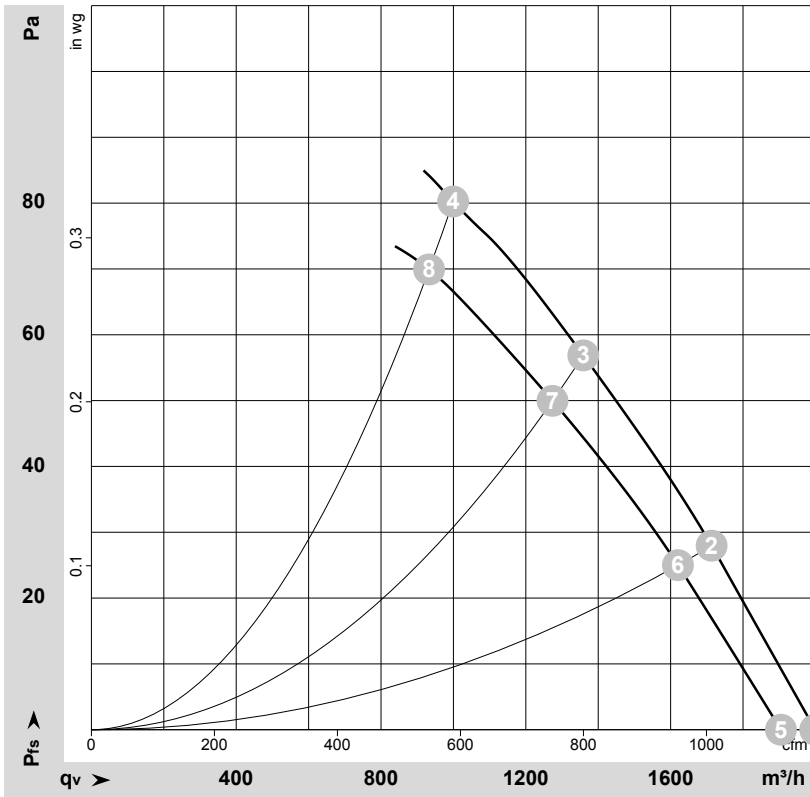

$\rho = 1.15 \text{ kg/m}^3 \pm 2 \%$

Measurement: LU-114654-1
Measurement: LU-114653-1

Air performance measured according to ISO 5801 installation category A. For detailed information on the measurement setup, contact ebm-papst. Intake sound level: Sound power level according to ISO 13347 / sound pressure level measured at 1 m distance from fan axis. The values given are valid under the specified measuring conditions and may vary due to conditions of installation. For deviations from the standard configuration, the parameters have to be checked on the installed unit.

Measured values

	Wired	U	f	n	P _e	I	LpA _{in}	LwA _{in}	q _v	P _{fs}	q _v	P _{fs}
		V	Hz	min ⁻¹	W	A	dB(A)	dB(A)	m ³ /h	Pa	cfm	in. wg
1	Y	480	60	1605	79	0.14			2000	0	1175	0.00
2	Y	480	60	1580	86	0.14			1715	28	1010	0.11
3	Y	480	60	1560	92	0.15			1360	57	800	0.23
4	Y	480	60	1510	105	0.16			1000	80	590	0.32
5	Y	400	60	1530	69	0.13	55	62	1905	0	1120	0.00
6	Y	400	60	1495	75	0.13	54	61	1620	25	955	0.10
7	Y	400	60	1460	80	0.14	54	61	1275	50	750	0.20
8	Y	400	60	1400	90	0.15	60	68	935	70	550	0.28

Wired = Wiring · U = Voltage · f = Frequency · n = Speed (rpm) · P_e = Power consumption · I = Current draw · LpA_{in} = Sound pressure level intake side · LwA_{in} = Sound power level intake side
q_v = Air flow · P_{fs} = Pressure increase

