

AC axial fan

straight blades (A series)

ebm-papst Mulfingen GmbH & Co. KG

Bachmühle 2 · D-74673 Mulfingen

Phone +49 7938 81-0

Fax +49 7938 81-110

sales@fansco.com

www.fansco.com

Limited partnership · Headquarters Mulfingen

Amtsgericht (court of registration) Stuttgart · HRA 590344

General partner Elektrobau Mulfingen GmbH · Headquarters Mulfingen

Amtsgericht (court of registration) Stuttgart · HRB 590142

Nominal data

Type	A2E300-AC47-02		
Motor	M2E068-EC		
Phase		1~	1~
Nominal voltage	VAC	230	230
Frequency	Hz	50	60
Method of obtaining data		fa	fa
Valid for approval/standard		CE	CE
Speed (rpm)	min ⁻¹	2650	2900
Power consumption	W	140	190
Current draw	A	0.62	0.83
Capacitor	µF	5	5
Capacitor voltage	VDB	400	400
Max. back pressure	Pa	150	150
Max. back pressure	in. wg	0.6	0.6
Min. ambient temperature	°C	-25	-25
Max. ambient temperature	°C	55	50

ml = Max. load · me = Max. efficiency · fa = Free air · cs = Customer specification · ce = Customer equipment
Subject to change

Data according to Commission Regulation (EU) 327/2011

	Actual	Req. 2015				
01 Overall efficiency η_{es}	%	28.7	28.6	09 Power consumption P_e	kW	0.16
02 Measurement category		A		09 Air flow q_v	m ³ /h	1650
03 Efficiency category		Static		09 Pressure increase p_{fs}	Pa	100
04 Efficiency grade N		40.1	40	10 Speed (rpm) n	min ⁻¹	2565
05 Variable speed drive		No		11 Specific ratio*		1.00

Data obtained at optimum efficiency level.
The ErP data is determined using a motor-impeller combination in a standardized measurement setup.

* Specific ratio = $1 + p_{fs} / 100\,000\text{ Pa}$

LU-66600



Technical description

Weight	2.5 kg
Fan size	300 mm
Rotor surface	Painted black
Impeller material	Sheet steel, painted black
Number of blades	5
Airflow direction	"A"
Direction of rotation	Clockwise, viewed toward rotor
Degree of protection	IP44
Insulation class	"B"
Moisture (F) / Environmental (H) protection class	H1
Max. permitted ambient temp. for motor (transport/storage)	+ 80 °C
Min. permitted ambient temp. for motor (transport/storage)	- 40 °C
Installation position	Shaft horizontal or rotor on bottom; rotor on top on request
Condensation drainage holes	On rotor side
Mode	S1
Motor bearing	Ball bearing
Touch current according to IEC 60990 (measuring circuit Fig. 4, TN system)	< 0.75 mA
Motor protection	Thermal overload protector (TOP) internally connected
With cable	Variable
Protection class	I (with customer connection of protective earth)
Conformity with standards	EN 60335-1; CE
Approval	CCC; EAC

Product drawing

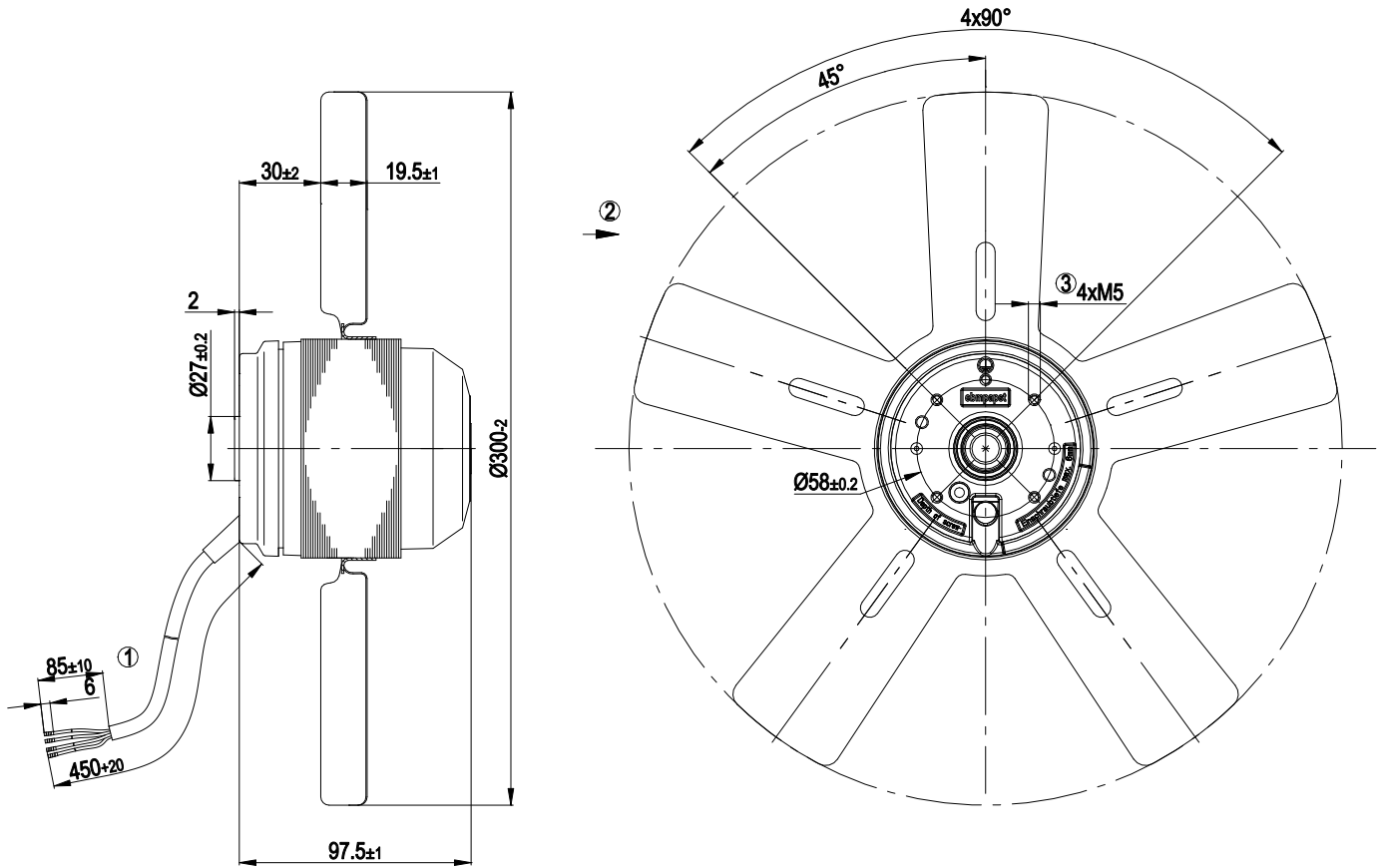

- 1 Cable PVC 4G 0.5mm², 4x crimped splices
- 2 Direction of air flow "A"

Connection diagram

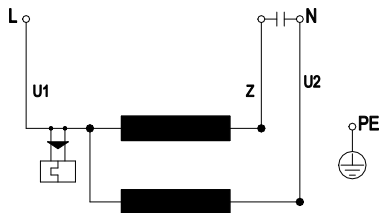

U1	blue	Z	brown	U2	black
PE	green/yellow				



Curves: Air performance 50 Hz

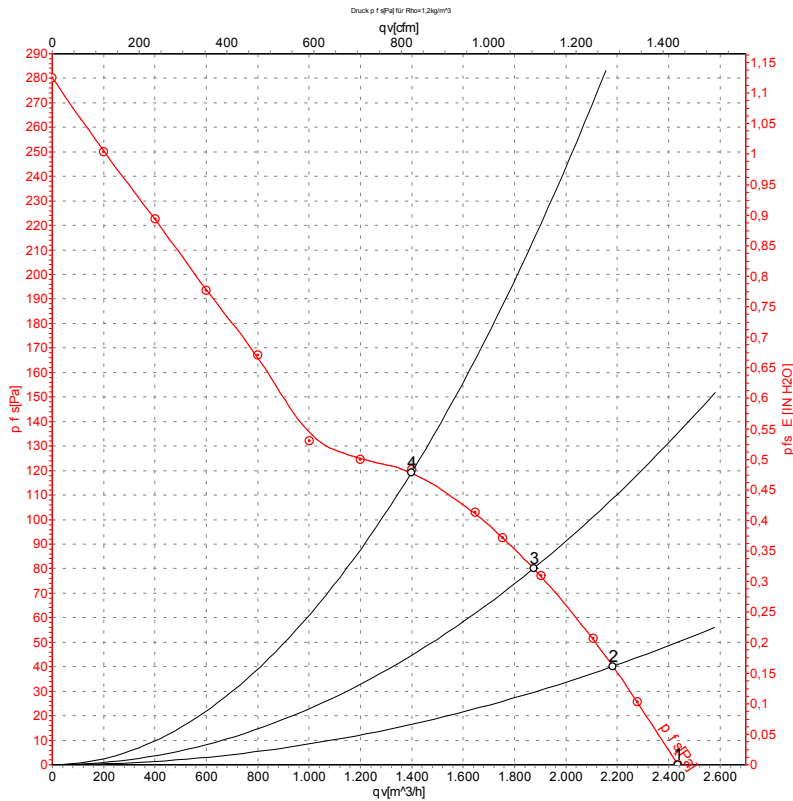

Measurement: LU-66600-1

Air performance measured according to ISO 5801 installation category A. For detailed information on the measurement setup, contact ebm-papst. Intake sound level: Sound power level according to ISO 13347 / sound pressure level measured at 1 m distance from fan axis. The values given are valid under the specified measuring conditions and may vary due to conditions of installation. For deviations from the standard configuration, the parameters have to be checked on the installed unit.

Measured values

	U	f	n	P _e	I	LpA _{in}	q _v	p _{fs}	q _v	p _{fs}
	V	Hz	min ⁻¹	W	A	dB(A)	m ³ /h	Pa	cfm	in. wg
1	230	50	2650	140	0.62	75	2435	0	1435	0.00
2	230	50	2615	151	0.66		2185	40	1285	0.16
3	230	50	2580	158	0.69		1875	80	1105	0.32
4	230	50	2560	162	0.71		1400	120	825	0.48

U = Power supply · f = Frequency · n = Speed (rpm) · P_e = Power consumption · I = Current draw · LpA_{in} = Sound pressure level intake side · q_v = Air flow · p_{fs} = Pressure increase



Curves: Air performance 60 Hz

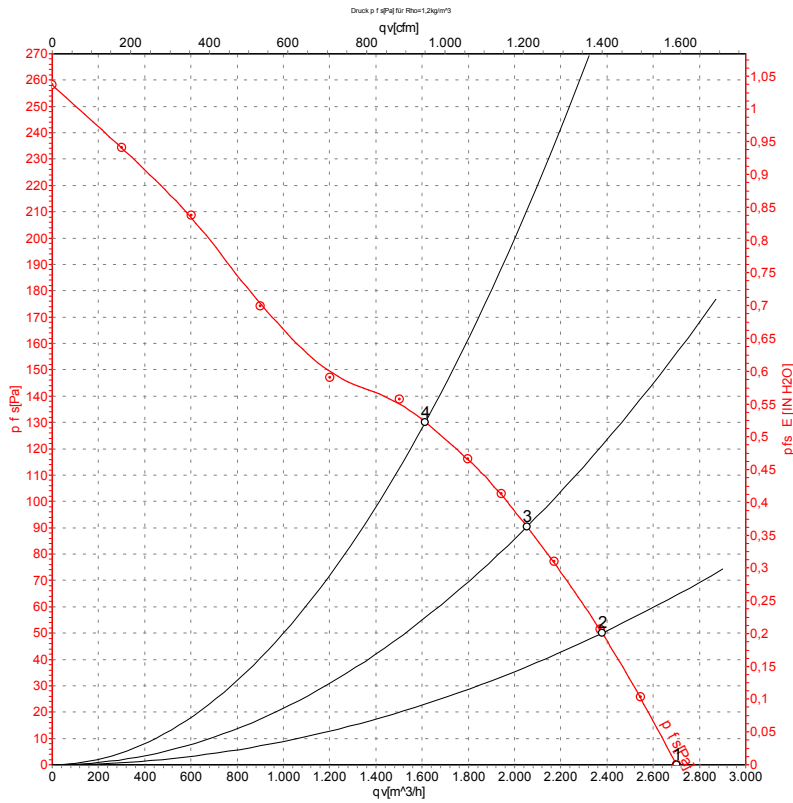

Measurement: LU-66601-1

Air performance measured according to ISO 5801 installation category A. For detailed information on the measurement setup, contact ebm-papst. Intake sound level: Sound power level according to ISO 13347 / sound pressure level measured at 1 m distance from fan axis. The values given are valid under the specified measuring conditions and may vary due to conditions of installation. For deviations from the standard configuration, the parameters have to be checked on the installed unit.

Measured values

	U	f	n	P _e	I	LpA _{in}	q _v	p _{fs}	q _v	p _{fs}
	V	Hz	min ⁻¹	W	A	dB(A)	m ³ /h	Pa	cfm	in. wg
1	230	60	2900	190	0.83	78	2700	0	1590	0.00
2	230	60	2865	205	0.90		2380	50	1400	0.20
3	230	60	2805	213	0.93		2055	90	1210	0.36
4	230	60	2755	218	0.95		1615	130	950	0.52

U = Power supply · f = Frequency · n = Speed (rpm) · P_e = Power consumption · I = Current draw · LpA_{in} = Sound pressure level intake side · q_v = Air flow · p_{fs} = Pressure increase

