

AC axial fan

sickle-shaped blades (S series)

ebm-papst Mulfingen GmbH & Co. KG

Bachmühle 2 · D-74673 Mulfingen

Phone +49 7938 81-0

Fax +49 7938 81-110

sales@fansco.com

www.fansco.com

Limited partnership · Headquarters Mulfingen

Amtsgericht (court of registration) Stuttgart · HRA 590344

General partner Elektrobau Mulfingen GmbH · Headquarters Mulfingen

Amtsgericht (court of registration) Stuttgart · HRB 590142

Nominal data

Type	A2E250-AN49-06				
Motor	M2E068-CA				
Phase		1~	1~	1~	1~
Nominal voltage	VAC	115	115	115	115
Frequency	Hz	50	50	60	60
Method of obtaining data		fa	fa	fa	fa
Valid for approval/standard		CE	UL 2111	CE	UL 2111
Speed (rpm)	min ⁻¹	2030	2030	1950	1950
Power consumption	W	75	85	90	100
Current draw	A	0.66	0.72	0.80	0.85
Capacitor	µF	6	6	6	6
Capacitor voltage	VDB	220	220	220	220
Max. back pressure	Pa	60	60	52	52
Max. back pressure	in. wg	0.24	0.24	0.21	0.21
Min. ambient temperature	°C	-25	-25	-25	-25
Max. ambient temperature	°C	75	75	60	60

ml = Max. load · me = Max. efficiency · fa = Free air · cs = Customer specification · ce = Customer equipment
Subject to change



Technical description

Weight	1.6 kg
Size	250 mm
Motor size	68
Rotor surface	Painted black
Impeller material	Sheet steel, painted black
Number of blades	7
Airflow direction	V
Direction of rotation	Counterclockwise, viewed toward rotor
Degree of protection	IP44; installation- and position-dependent
Insulation class	"B"
Moisture (F) / Environmental (H) protection class	H1
Max. permitted ambient temp. for motor (transport/storage)	+ 80 °C
Min. permitted ambient temp. for motor (transport/storage)	- 40 °C
Installation position	Any
Condensation drainage holes	None
Mode	S1
Motor bearing	Ball bearing; (sealed)
Touch current according to IEC 60990 (measuring circuit Fig. 4, TN system)	< 0.75 mA
Motor protection	Thermal overload protector (TOP) internally connected
With cable	Variable
Protection class	I (with customer connection of protective earth)
Conformity with standards	EN 60034-1; EN 60204-1; EN 60335-1; CE
Approval	CSA C22.2 No. 113; UL 507

Product drawing

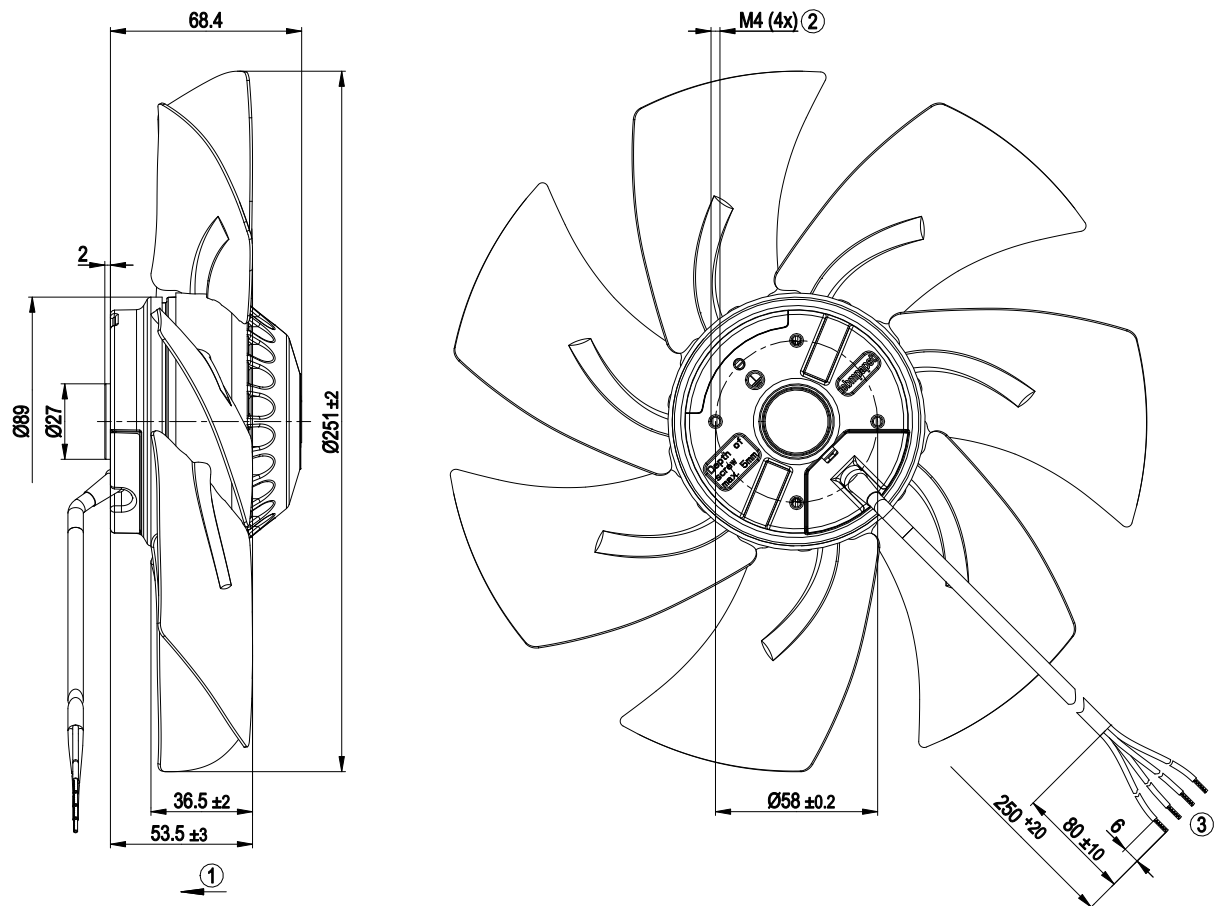

1	Direction of air flow "V"
2	Max. clearance for screw 5 mm
3	Cable PVC 4G 0.5 mm ²
	4x splice

AC axial fan

sickle-shaped blades (S series)

Connection diagram

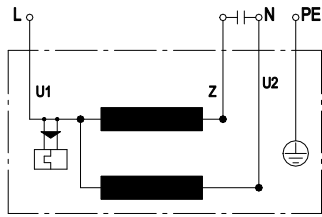

U1	blue	Z	brown	U2	black
PE	green/yellow				

Curves: Air performance 50 Hz

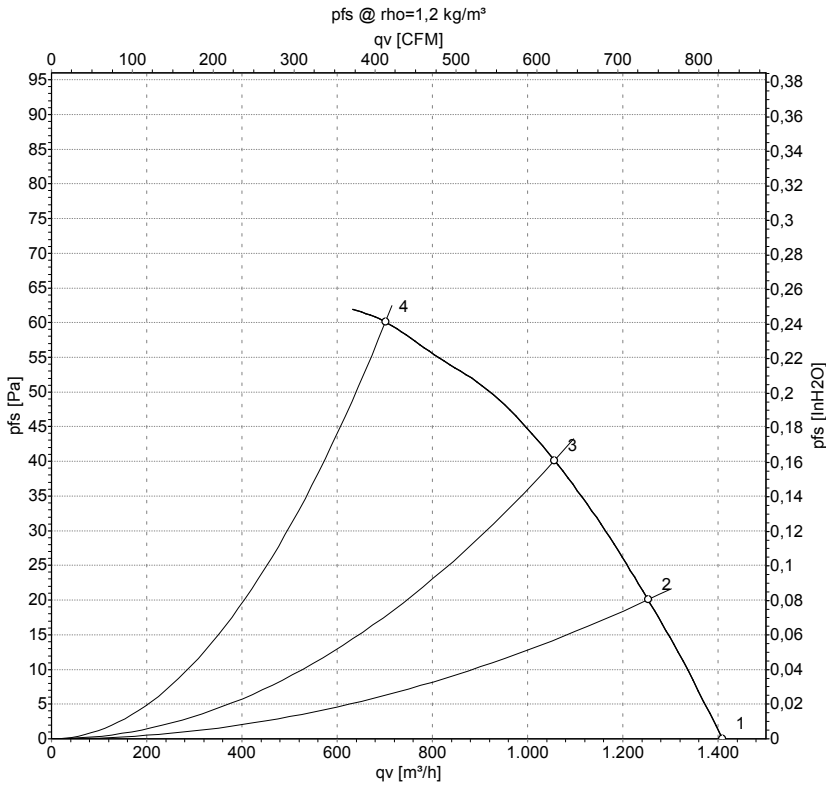

Measurement: LU-73792-1

Air performance measured according to ISO 5801 installation category A. For detailed information on the measurement setup, contact ebm-papst. Intake sound level: Sound power level according to ISO 13347 / sound pressure level measured at 1 m distance from fan axis. The values given are valid under the specified measuring conditions and may vary due to conditions of installation. For deviations from the standard configuration, the parameters have to be checked on the installed unit.

Measured values

	U	f	n	P _e	I	q _v	p _{fs}	q _v	p _{fs}
	V	Hz	min ⁻¹	W	A	m ³ /h	Pa	cfm	in. wg
1	115	50	2030	75	0.66	1410	0	830	0.00
2	115	50	1925	75	0.66	1250	20	735	0.08
3	115	50	1830	79	0.68	1055	40	620	0.16
4	115	50	1780	80	0.69	700	60	415	0.24

U = Voltage · f = Frequency · n = Speed (rpm) · P_e = Power consumption · I = Current draw · q_v = Air flow · p_{fs} = Pressure increase



Curves: Air performance 60 Hz

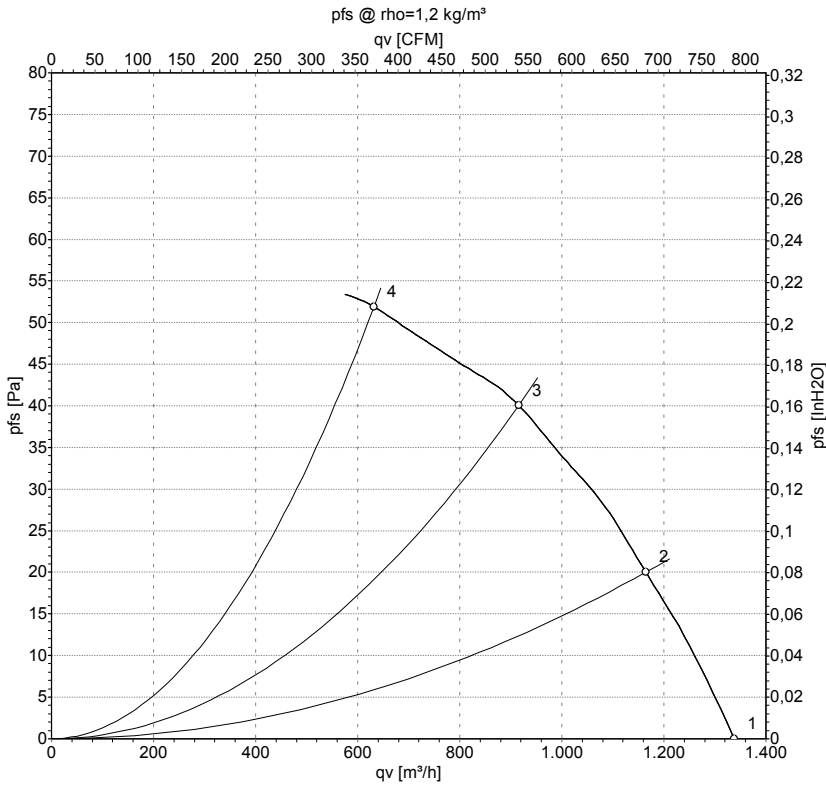

Measurement: LU-73793-1

Air performance measured according to ISO 5801 installation category A. For detailed information on the measurement setup, contact ebm-papst. Intake sound level: Sound power level according to ISO 13347 / sound pressure level measured at 1 m distance from fan axis. The values given are valid under the specified measuring conditions and may vary due to conditions of installation. For deviations from the standard configuration, the parameters have to be checked on the installed unit.

Measured values

	U	f	n	P _e	I	q _v	p _{fs}	q _v	p _{fs}
	V	Hz	min ⁻¹	W	A	m³/h	Pa	cfm	in. wg
1	115	60	1950	90	0.80	1340	0	790	0.00
2	115	60	1815	89	0.77	1165	20	685	0.08
3	115	60	1690	92	0.79	915	40	540	0.16
4	115	60	1670	92	0.79	630	52	370	0.21

U = Voltage · f = Frequency · n = Speed (rpm) · P_e = Power consumption · I = Current draw · q_v = Air flow · p_{fs} = Pressure increase

