

# AC axial fan

straight blades (A series)

## ebm-papst Mulfingen GmbH & Co. KG

Bachmühle 2 · D-74673 Mulfingen

Phone +49 7938 81-0

Fax +49 7938 81-110

sales@fansco.com

www.fansco.com

Limited partnership · Headquarters Mulfingen

Amtsgericht (court of registration) Stuttgart · HRA 590344

General partner Elektrobau Mulfingen GmbH · Headquarters Mulfingen

Amtsgericht (court of registration) Stuttgart · HRB 590142

### Nominal data

Type	A2D250-AA06-84		
Motor	M2D068-DF		
Phase		3~	3~
Nominal voltage	VAC	265	460
Wiring		Δ	Y
Frequency	Hz	60	60
Method of obtaining data		fa	fa
Valid for approval/standard		CE	CE
Speed	min <sup>-1</sup>	2900	2900
Power consumption	W	150	150
Current draw	A	0.38	0.22
Max. back pressure	Pa	125	125
Min. ambient temperature	°C	-25	-25
Max. ambient temperature	°C	65	65

ml = Max. load · me = Max. efficiency · fa = Free air · cs = Customer specification · ce = Customer equipment  
Subject to change



## Technical description

<b>Weight</b>	2.5 kg
<b>Fan size</b>	250 mm
<b>Rotor surface</b>	Painted black
<b>Terminal box material</b>	Die-cast aluminum
<b>Terminal box cover material</b>	Die-cast aluminum
<b>Impeller material</b>	Sheet steel, painted black
<b>Number of blades</b>	5
<b>Airflow direction</b>	"A"
<b>Direction of rotation</b>	Clockwise, viewed toward rotor
<b>Degree of protection</b>	IP54
<b>Insulation class</b>	"B"
<b>Moisture (F) / Environmental (H) protection class</b>	F3-1
<b>Max. permitted ambient temp. for motor (transport/storage)</b>	+ 80 °C
<b>Min. permitted ambient temp. for motor (transport/storage)</b>	- 40 °C
<b>Installation position</b>	Shaft horizontal or rotor on bottom; rotor on top on request
<b>Condensation drainage holes</b>	None
<b>Mode</b>	S1
<b>Motor storage</b>	Ball bearing
<b>Touch current according to IEC 60990 (measuring circuit Fig. 4, TN system)</b>	< 0.75 mA
<b>Electrical hookup</b>	Via terminal box
<b>With cable</b>	Axial
<b>Protection class</b>	I (with customer connection of protective earth)
<b>Conformity with standards</b>	EN 60335-1

## Product drawing

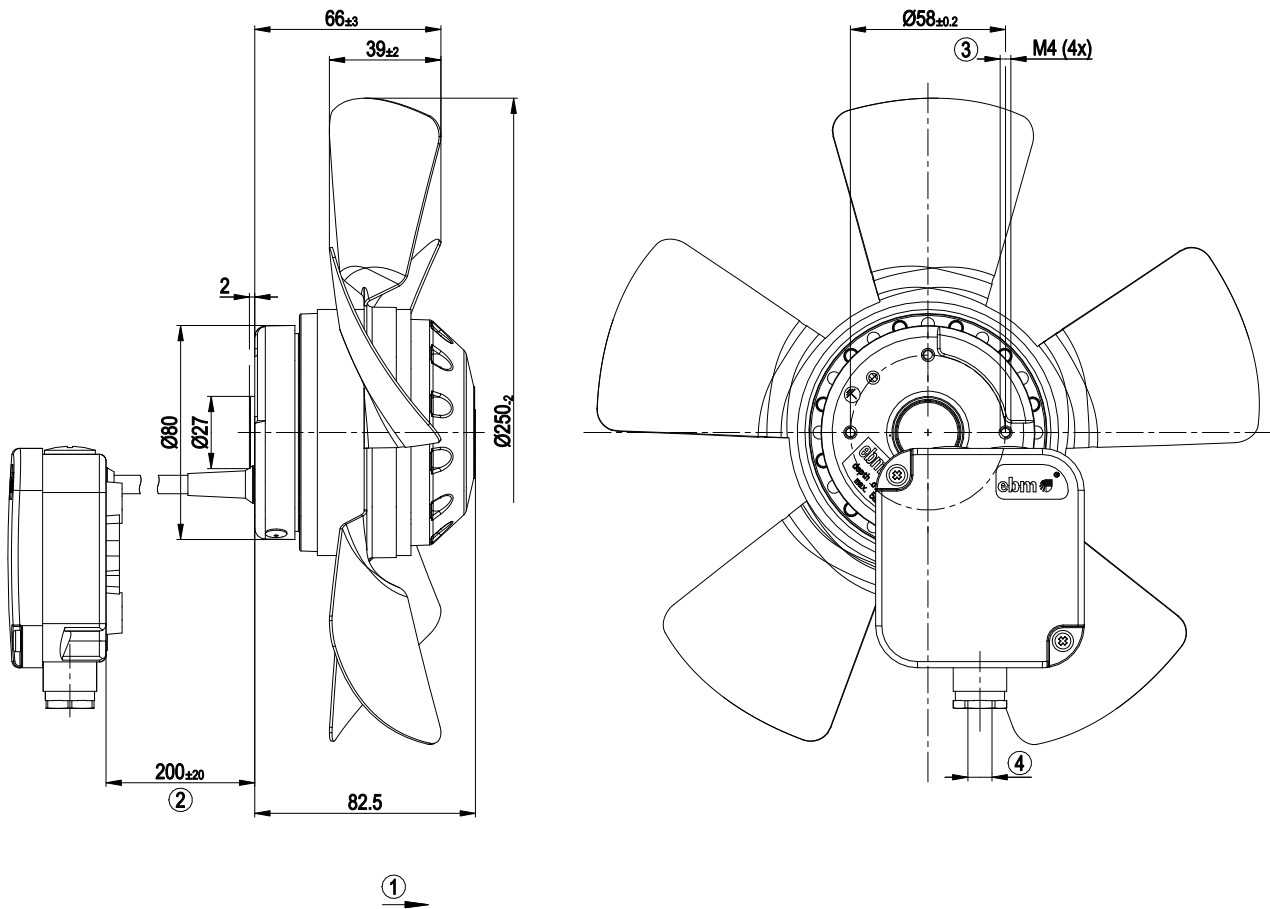

1	Direction of air flow "A"
2	Cable A03VV-F7G0.5
3	Max. clearance for screw 5 mm
4	Cable diameter min. 6 mm, max. 9 mm

## Connection diagram

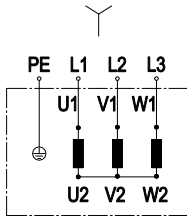

Change of rotation direction by reversing two phases

	Three-phase motor	Y	Star connection	L1	black
L2	blue	L3	brown	PE	green/yellow

## Curves: Air performance 60 Hz

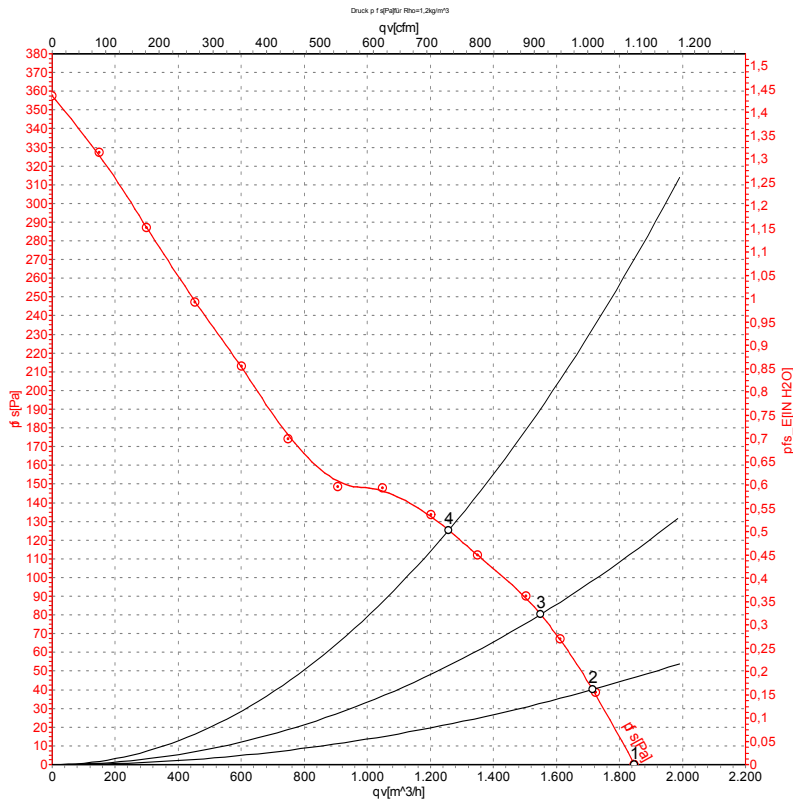

Measurement: LU-110509

Air performance measured according to ISO 5801 installation category A. For detailed information on the measurement setup, contact ebm-papst. Intake sound level: Sound power level according to ISO 13347 / sound pressure level measured at 1 m distance from fan axis. The values given are valid under the specified measuring conditions and may vary due to conditions of installation. For deviations from the standard configuration, the parameters have to be checked on the installed unit.

## Measured values

	Wired	U	f	n	P <sub>e</sub>	I	qv	p <sub>fs</sub>
		V	Hz	min <sup>-1</sup>	W	A	m <sup>3</sup> /h	Pa
1	Y	460	60	2900	150	0.22	1850	0
2	Y	460	60	2835	160	0.23	1715	40
3	Y	460	60	2800	166	0.23	1550	80
4	Y	460	60	2765	172	0.24	1260	125

Wired = Wiring · U = Power supply · f = Frequency · n = Speed · P<sub>e</sub> = Power consumption · I = Current draw · qv = Air flow · p<sub>fs</sub> = Pressure increase

