

AC axial fan

straight blades (A series), single-intake

ebm-papst Mulfingen GmbH & Co. KG

Bachmühle 2 · D-74673 Mulfingen

Phone +49 7938 81-0

Fax +49 7938 81-110

sales@fansco.com

www.fansco.com

Limited partnership · Headquarters Mulfingen

Amtsgericht (court of registration) Stuttgart · HRA 590344

General partner Elektrobau Mulfingen GmbH · Headquarters Mulfingen

Amtsgericht (court of registration) Stuttgart · HRB 590142

Nominal data

Type	A2D200-AA04-29		
Motor	M2D068-CF		
Phase		3~	3~
Nominal voltage	VAC	265	460
Wiring		Δ	Y
Frequency	Hz	60	60
Method of obtaining data		fa	fa
Valid for approval/standard		-	-
Speed (rpm)	min ⁻¹	3100	3100
Power consumption	W	65	65
Current draw	A	0.19	0.11
Min. ambient temperature	°C	-25	-25
Max. ambient temperature	°C	80	80

ml = Max. load · me = Max. efficiency · fa = Free air · cs = Customer specification · ce = Customer equipment
Subject to change



Technical description

Weight	1.8 kg
Size	200 mm
Motor size	68
Rotor surface	Painted black
Blade material	Sheet steel, painted black
Number of blades	5
Airflow direction	A
Direction of rotation	Clockwise, viewed toward rotor
Degree of protection	IP44; installation- and position-dependent
Insulation class	"B"
Moisture (F) / Environmental (H) protection class	H0 - dry environment
Max. permitted ambient temp. for motor (transport/storage)	+ 80 °C
Min. permitted ambient temp. for motor (transport/storage)	- 40 °C
Installation position	Any
Condensation drainage holes	None
Mode	S1
Motor bearing	Ball bearing
Touch current according to IEC 60990 (measuring circuit Fig. 4, TN system)	< 0.75 mA
With cable	Axial
Protection class	I (with customer connection of protective earth)
Conformity with standards	EN 60335-1, motor does not have factory-installed overheating protection; CE

AC axial fan

straight blades (A series), single-intake

Product drawing

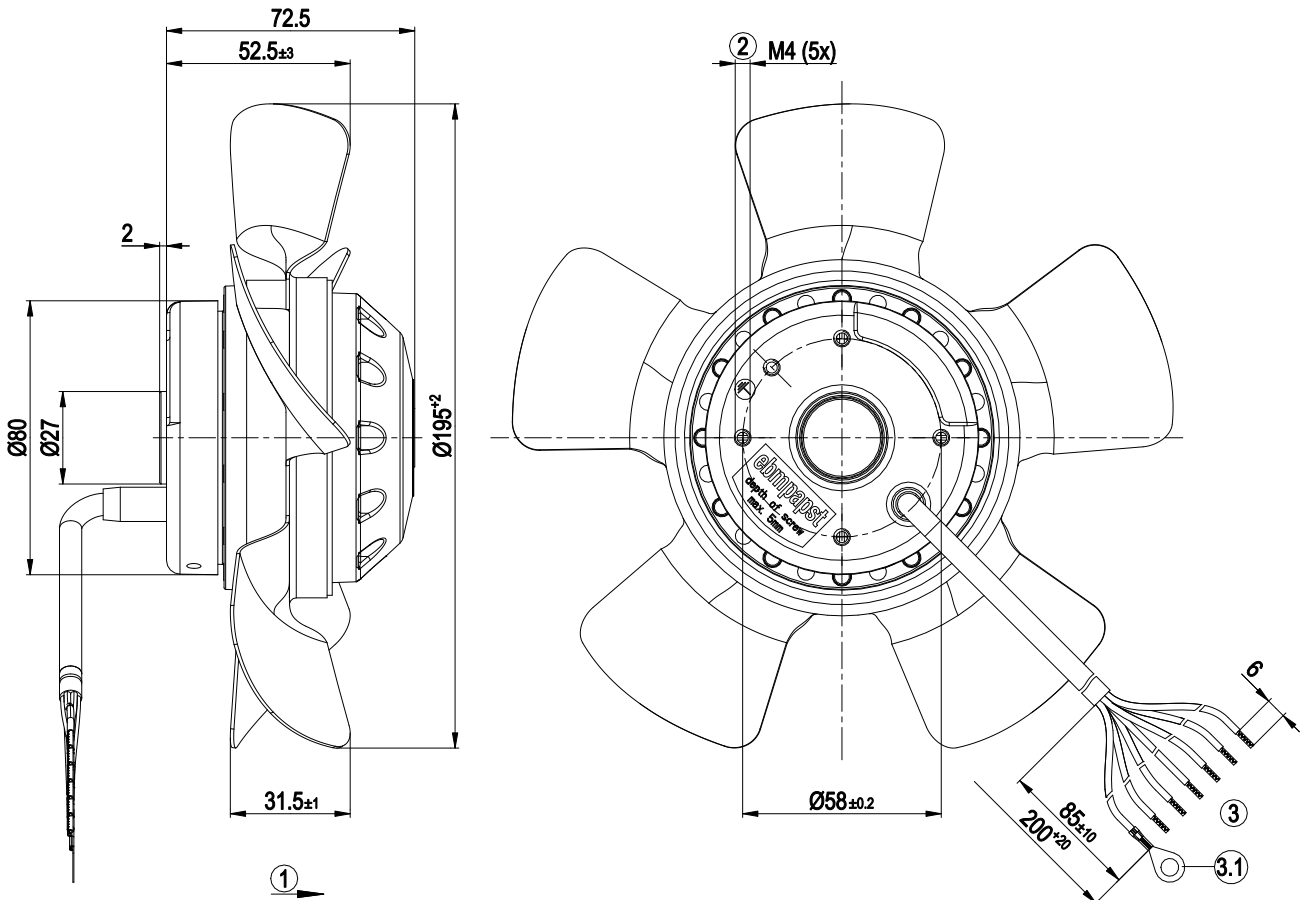

1	Direction of air flow "A"
2	Max. clearance for screw 5 mm
3	Cable PVC 7G 0.5 mm ²
	6x splice
	1x ring terminal, dia. 4.3 (PE)



Accessory part

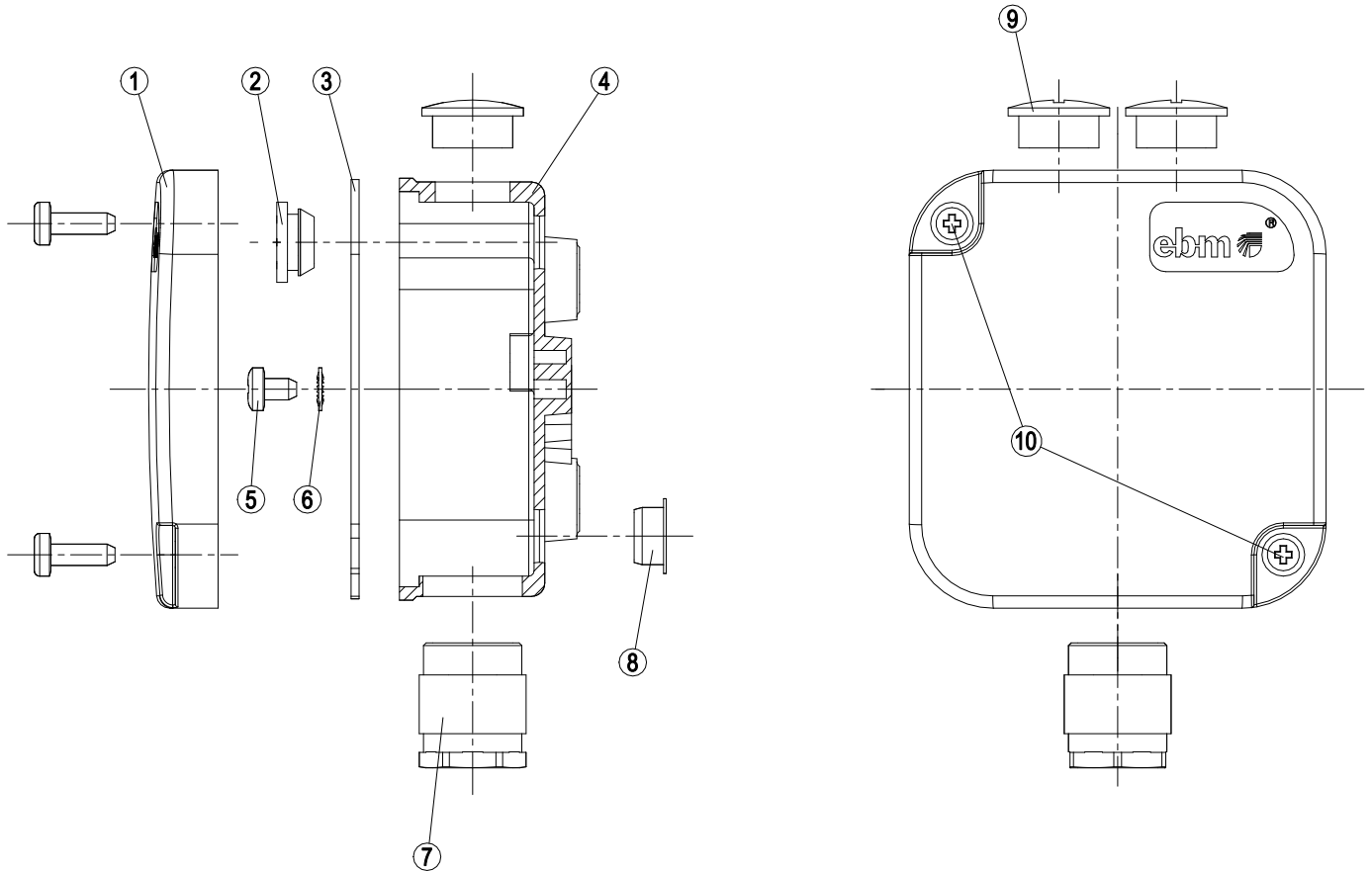

Accessory parts, included separately:

1	Terminal box cover
2	Grommet
3	Seal
4	Base of terminal box
5	Oval-head screw
6	Toothed lock washer
7	Cable gland, cable diameter min. 8 mm, max. 10 mm, tightening torque 1.3 ± 0.2 Nm
8	Stopper
9	Screw plugs (2x), tightening torque 1.3 ± 0.2 Nm
10	2x oval-head screws, tightening torque 1.3 ± 0.2 Nm

AC axial fan

straight blades (A series), single-intake

Connection diagram

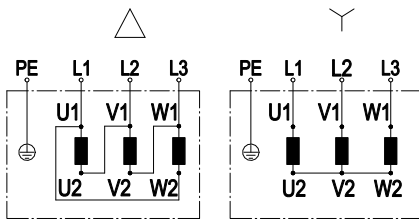

Change of rotation direction by reversing two phases

	Three-phase motor	Δ	Delta connection	Y	Star connection
L1	= U1 = black	L2	= V1 = blue	L3	= W1 = brown
U2	green	V2	white	W2	yellow
PE	green/yellow				



Curves: Air performance 60 Hz

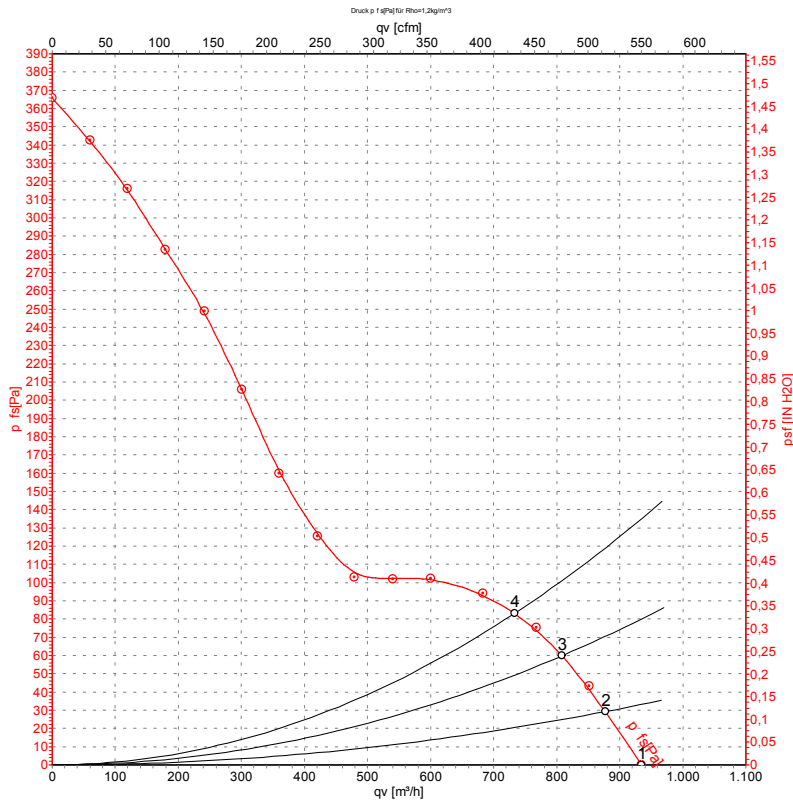

Measurement: LU-141894-1

Air performance measured according to ISO 5801 installation category A. For detailed information on the measurement setup, contact ebm-papst. Intake sound level: Sound power level according to ISO 13347 / sound pressure level measured at 1 m distance from fan axis. The values given are valid under the specified measuring conditions and may vary due to conditions of installation. For deviations from the standard configuration, the parameters have to be checked on the installed unit.

Measured values

	U	f	n	P _e	I	q _v	p _{fs}	q _v	p _{fs}
	V	Hz	min ⁻¹	W	A	m³/h	Pa	cfm	in. wg
1	500	60	3150	70	0.11	935	0	550	0.00
2	500	60	3130	72	0.11	875	30	515	0.12
3	500	60	3110	74	0.11	810	60	475	0.24
4	500	60	3100	75	0.11	735	83	430	0.33

U = Voltage · f = Frequency · n = Speed (rpm) · P_e = Power consumption · I = Current draw · q_v = Air flow · p_{fs} = Pressure increase

