

## AC axial fan

sickle-shaped blades (S series)

**ebm-papst Mulfingen GmbH & Co. KG**

Bachmühle 2 · D-74673 Mulfingen

Phone +49 7938 81-0

Fax +49 7938 81-110

sales@fansco.com

www.fansco.com

Limited partnership · Headquarters Mulfingen

Amtsgericht (court of registration) Stuttgart · HRA 590344

General partner Elektrobau Mulfingen GmbH · Headquarters Mulfingen

Amtsgericht (court of registration) Stuttgart · HRB 590142

**Nominal data**

Type	A2D200-AA02-16				
Motor	M2D068-CF				
Phase		3~	3~	3~	3~
Nominal voltage	VAC	230	230	400	400
Wiring		Δ	Δ	Y	Y
Frequency	Hz	50	60	50	60
Method of obtaining data		fa	fa	fa	fa
Valid for approval/standard		CE	CE	CE	CE
Speed (rpm)	min <sup>-1</sup>	2800	3150	2800	3150
Power consumption	W	53	70	53	70
Current draw	A	0.26	0.24	0.15	0.14
Max. back pressure	Pa	200	300	200	300
Max. back pressure	in. wg	0.8	1.2	0.8	1.2
Min. ambient temperature	°C	-25	-25	-25	-25
Max. ambient temperature	°C	75	75	75	75
Starting current	A	0.81	0.78	0.47	0.45

ml = Max. load · me = Max. efficiency · fa = Free air · cs = Customer specification · ce = Customer equipment  
Subject to change



### Technical description

<b>Weight</b>	1.7 kg
<b>Size</b>	200 mm
<b>Motor size</b>	68
<b>Rotor surface</b>	Painted black
<b>Blade material</b>	Sheet steel, hot-dip galvanized
<b>Number of blades</b>	5
<b>Airflow direction</b>	V
<b>Direction of rotation</b>	Counterclockwise, viewed toward rotor
<b>Degree of protection</b>	IP54; installation- and position-dependent as per EN 60034-5
<b>Insulation class</b>	"B"
<b>Moisture (F) / Environmental (H) protection class</b>	H1+; F3-1
<b>Max. permitted ambient temp. for motor (transport/storage)</b>	+ 80 °C
<b>Min. permitted ambient temp. for motor (transport/storage)</b>	- 40 °C
<b>Installation position</b>	Shaft horizontal or rotor on bottom; rotor on top on request
<b>Condensation drainage holes</b>	On rotor side
<b>Mode</b>	S1
<b>Motor bearing</b>	Ball bearing
<b>Touch current according to IEC 60990 (measuring circuit Fig. 4, TN system)</b>	< 0.75 mA
<b>With cable</b>	Lateral
<b>Protection class</b>	I (with customer connection of protective earth)
<b>Conformity with standards</b>	EN 60335-1

Product drawing

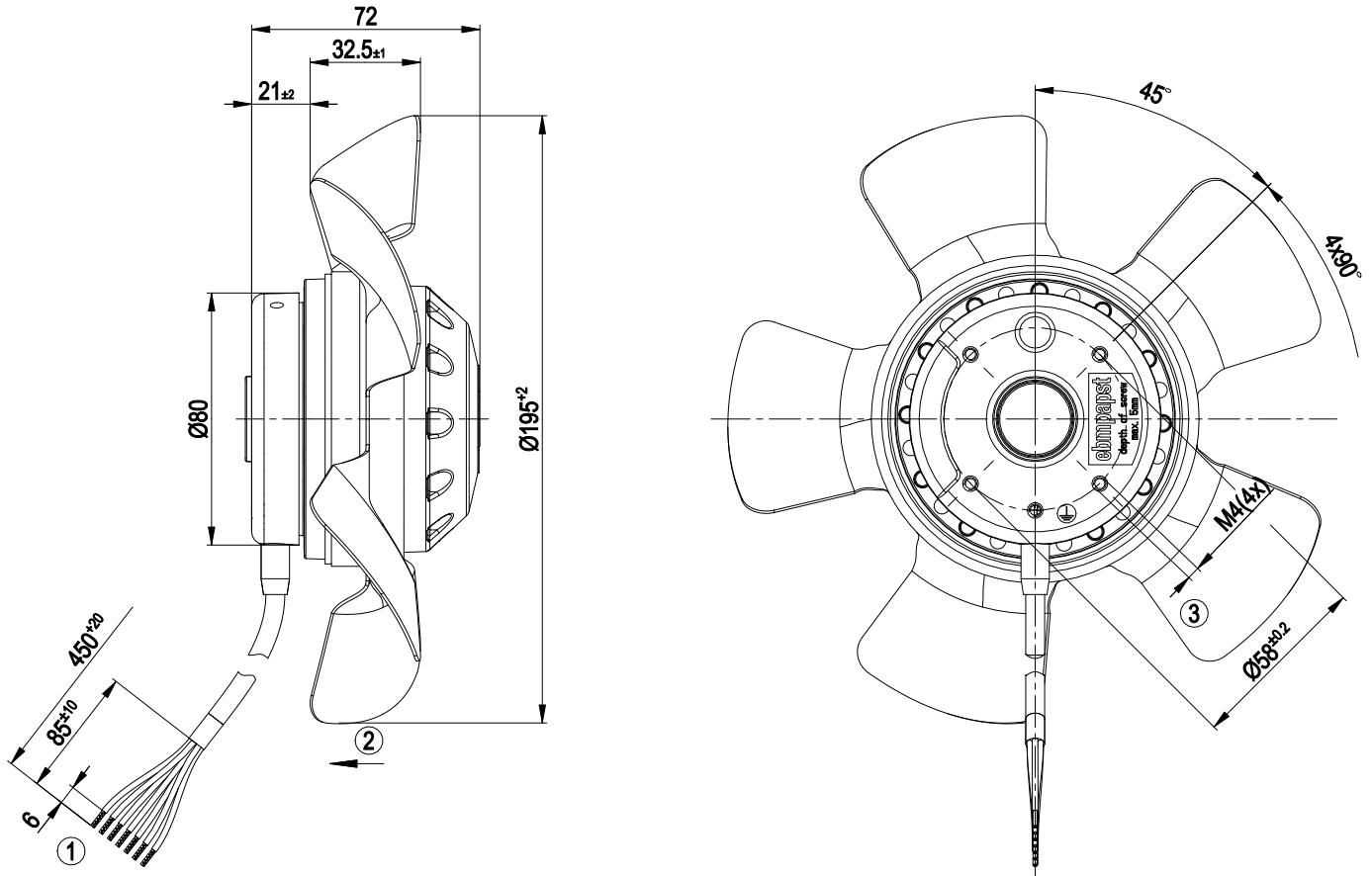

1	Cable Dipotherm 7G 0.5 mm <sup>2</sup> , 7x crimped splice
2	Direction of air flow "V"
3	Max. clearance for screw 5 mm



## Connection diagram

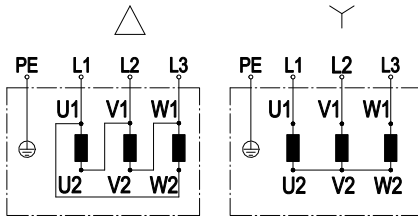

Change of rotation direction by reversing two phases

	Three-phase motor	Δ	Delta connection	Y	Star connection
L1	= U1 = black	L2	= V1 = blue	L3	= W1 = brown
U2	green	V2	white	W2	yellow
PE	green/yellow				

## Curves: Air performance 50 Hz

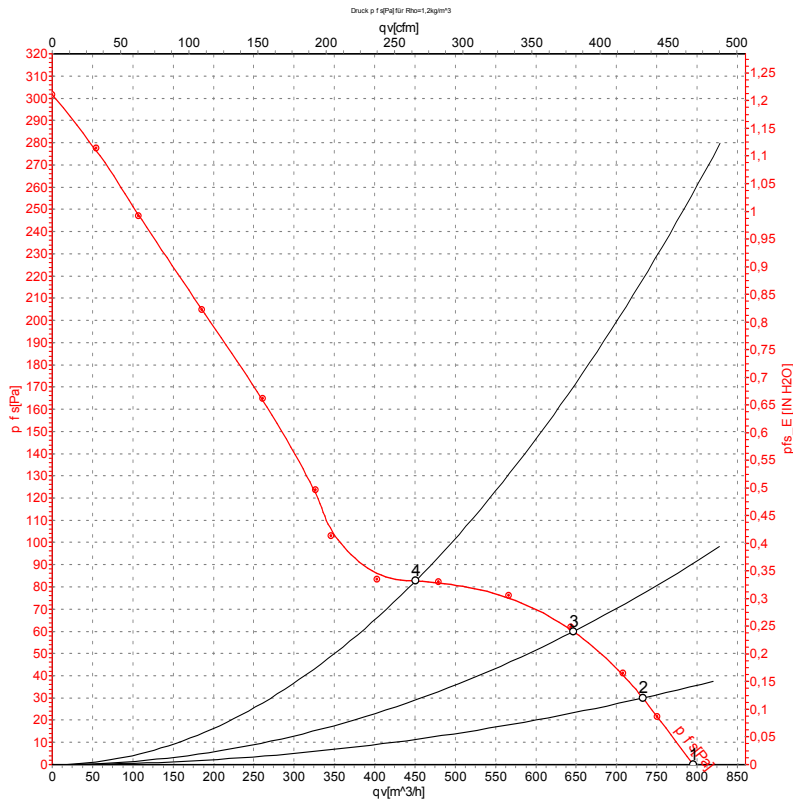

Measurement: LU-58516-1

Air performance measured according to ISO 5801 installation category A. For detailed information on the measurement setup, contact ebm-papst. Intake sound level: Sound power level according to ISO 13347 / sound pressure level measured at 1 m distance from fan axis. The values given are valid under the specified measuring conditions and may vary due to conditions of installation. For deviations from the standard configuration, the parameters have to be checked on the installed unit.

## Measured values

	U	f	n	P <sub>e</sub>	I	q <sub>v</sub>	P <sub>is</sub>	q <sub>v</sub>	P <sub>is</sub>
	V	Hz	min <sup>-1</sup>	W	A	m <sup>3</sup> /h	Pa	cfm	in. wg
1	400	50	2800	53	0.15	800	0	470	0.00
2	400	50	2800	54	0.15	735	30	430	0.12
3	400	50	2800	56	0.15	645	60	380	0.24
4	400	50	2800	52	0.15	450	83	265	0.33

U = Voltage · f = Frequency · n = Speed (rpm) · P<sub>e</sub> = Power consumption · I = Current draw · q<sub>v</sub> = Air flow · P<sub>is</sub> = Pressure increase



## Curves: Air performance 60 Hz

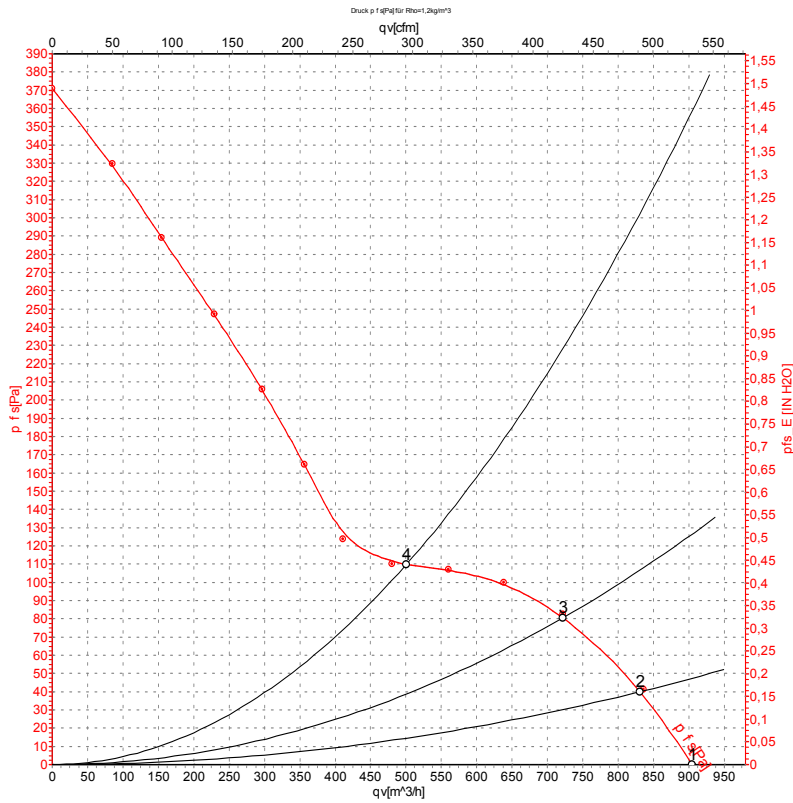

Measurement: LU-58517-1

Air performance measured according to ISO 5801 installation category A. For detailed information on the measurement setup, contact ebm-papst. Intake sound level: Sound power level according to ISO 13347 / sound pressure level measured at 1 m distance from fan axis. The values given are valid under the specified measuring conditions and may vary due to conditions of installation. For deviations from the standard configuration, the parameters have to be checked on the installed unit.

## Measured values

	U	f	n	P <sub>e</sub>	I	q <sub>v</sub>	P <sub>fs</sub>	q <sub>v</sub>	P <sub>fs</sub>
	V	Hz	min <sup>-1</sup>	W	A	m³/h	Pa	cfm	in. wg
1	400	60	3150	70	0.14	910	0	535	0.00
2	400	60	3150	71	0.14	830	40	490	0.16
3	400	60	3150	74	0.14	720	80	425	0.32
4	400	60	3150	69	0.13	500	110	295	0.44

U = Voltage · f = Frequency · n = Speed (rpm) · P<sub>e</sub> = Power consumption · I = Current draw · q<sub>v</sub> = Air flow · P<sub>fs</sub> = Pressure increase

