

Product Data Sheet

8315100209

VWJK100TKGRS

AT100 Standard

ebmpapst

engineering a better life



AT100 Standard

INDEX

1	General	3
2	Mechanics	3
2.1	General	3
2.2	Connections	3
3	Operating Data	5
3.1	Electrical Interface - Input	5
3.2	Electrical Operating Data	7
3.3	Electrical Interface - Output	8
3.4	Electrical Features	9
3.5	Data According ErP Directive	9
3.6	Aerodynamics	10
3.7	Sound Data	11
4	Environment	11
4.1	General	11
4.2	Climatic Requirements	11
4.3	Mechanical Requirements	12
4.4	EMC	12
5	Safety	14
5.1	Electrical Safety	14
5.2	Approval Tests	14
6	Reliability	14
6.1	General	14

1 General

Fan type	Axial	
Rotating direction looking at rotor	Clockwise	
Airflow direction	Air inlet and air outlet axially	
Bearing system	Ball bearing	
Mounting position - shaft	Any	

2 Mechanics**2.1 General**

Width	100 mm	
Height	100 mm	
Depth	90 mm	
Diameter	96 mm	
Mass	0,59 kg	
Housing material	Mixed	
Impeller material	Mixed	

2.2 Connections

Electrical connection	Wires - Plug	
Lead wire length	L = 310 mm	
Tolerance	+ - 10 mm	
Tube length	S = 10 mm	
Tolerance	+ - 5 mm	
Plug	See drawing	
Contact	See drawing	



Steckerbelegung/
Connector connection

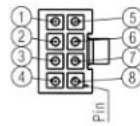

Fan No.	Wire color for Sample	Signal name	Connector Pos.
FAN 1	red AWG 22	P48V	1
FAN 1	black AWG 22	GND	2
FAN 1	blue AWG 24	PWM	3
FAN 1	yellow AWG 24	Tacho	4
FAN 2	red AWG 22	P48V	5
FAN 2	black AWG 22	GND	6
FAN 2	white AWG 24	PWM	7
FAN 2	brown AWG 24	Tacho	8

Wire	Color	Operation	Plug connection	Wire size	Insulation diameter
1	red	+ UB	Pin 1	AWG 22	1,3 mm
2	black	- GND	Pin 2	AWG 22	1,3 mm
3	blue	PWM	Pin 3	AWG 24	1,1 mm
4	yellow	Tacho	Pin 4	AWG 24	1,1 mm
5	red	+ UB	Pin 5	AWG 22	1,3 mm
6	black	- GND	Pin 6	AWG 22	1,3 mm
7	white	PWM	Pin 7	AWG 24	1,1 mm
8	brown	Tacho	Pin 8	AWG 24	1,1 mm

The auxiliaries shown on the schematic diagram (which are required for the intended use) are not part of our delivery.

Connector:

Fan 1: Inlet-side plug Pin 1 to 4;

Fan 2: Outlet-side plug Pin 5 to 8.

3 Operating Data

3.1 Electrical Interface - Input

Control input	PWM
---------------	-----

Features

Inpute type	Open collector / TTL	
PWM - Frequency		1 kHz - 10 kHz typical: 2 kHz
Input voltage range		3,3 V - 20 V
Max. voltage for logic "Low"		0,4 V
Max. voltage for logic "High"	Open circuit voltage	20,0 V
Maximum source current	short circuit current	$\leq 0,2$ mA

<p>Characteristics</p>	
<p>Schematics</p>	

PWM input transistor requirements:

$U_{CEmax.} \Rightarrow 25 \text{ V}$; $I_{\text{Sink max.}} > 5 \text{ mA}$; $U_{CEsat.} < 0,15 \text{ V}$

Customer request:

Without input signal fan is running at maximum Speed.
Internal pullup resistor 22k to 5VDC.

Fan can be controlled with active and open collector-PWM!

Note to speed characteristic curve:

Green curve show the characteristic of fan inlet side

Blue curve show the characteristic of fan outlet side

3.2 Electrical Operating Data

Measurement conditions: Normal air density = 1,2 kg/m³; Temperature 23°C +/- 3°C; Motor axis horizontal; warm-up time before measuring 5 minutes. In the intake and outlet area should not be any solid obstruction within 0,5 m.

$\Delta p = 0$: corresp. to free air flow (see chapter aerodynamics)
I: corresp. to arithm. mean current value

Name	Condition
PWM 0001	PWM: 100 %; f: 2 kHz

Note to electrical operating PWM 0001:

current measured on both stages together,
speed measured on inlet side!

Note:

Inrush current @ U nom:
see 3.4 Electrical Features

Electrical operating data of outlet side

Features	Condition	Symbol	Values		
Voltage range		U	36 V		60 V
Nominal voltage		U _N		48 V	
Power consumption	$\Delta p = 0$	P	100 W	140 W	140 W
Tolerance	PWM 0010		+/- 15 %	+/- 12 %	+/- 10 %
Current consumption	$\Delta p = 0$	I	2.800 mA	2.900 mA	2.300 mA
Tolerance	PWM 0010		+/- 12 %	+/- 10 %	+/- 10 %
Speed	$\Delta p = 0$	n	11.000 1/min	11.000 1/min	11.000 1/min
Tolerance	PWM 0010		+/- 5 %	+/- 3 %	+/- 3 %
Starting current consumption				<= 3.500 mA	

3.3 Electrical Interface - Output

Tacho type	/2 (open collector)
------------	---------------------

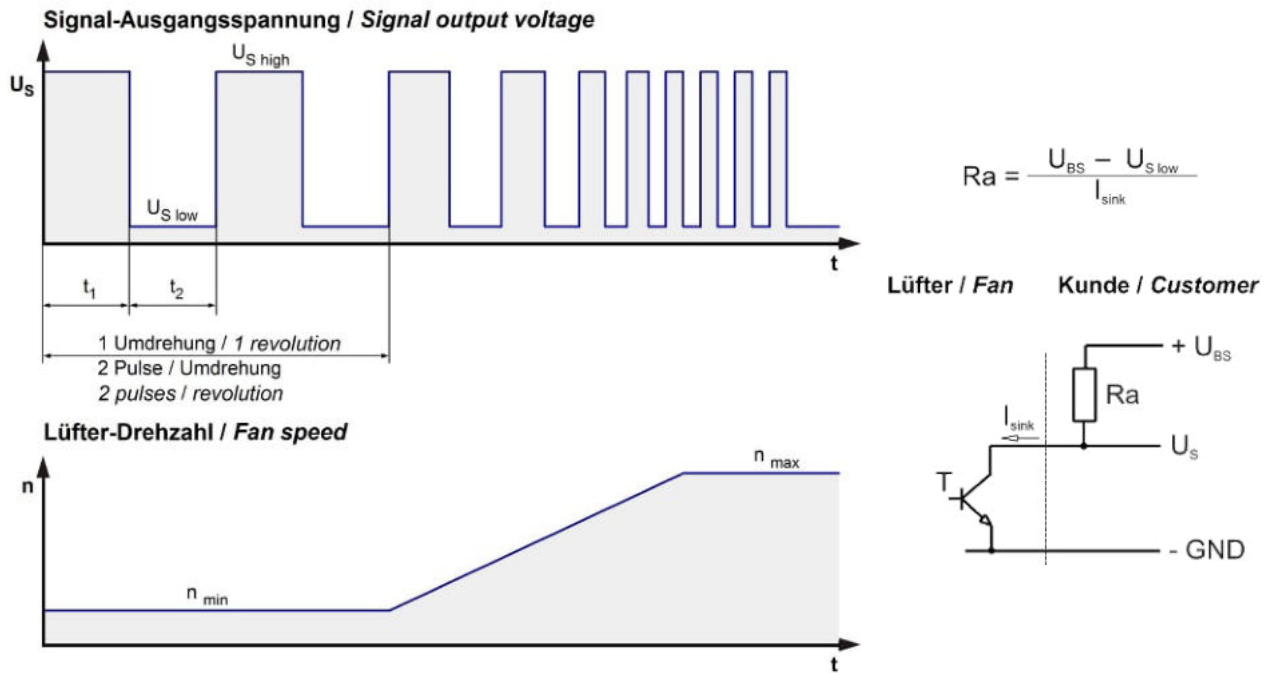

Tacho type	/2 (open collector)
------------	---------------------

Features	Note	Values
Tacho operating voltage	U_{BS}	$\leq 60\ V$
Tacho signal Low	$U_{S\ low}$	$I_{sink}: 20\ mA$ $\leq 0,4\ V$
Tacho signal High	$U_{S\ high}$	$I_{source}: 0\ mA$ $\leq 60\ V$
External resistor	External resistor R_a from U_{BS} to U_s required. All voltages measured to GND.	
Tacho frequency		366 Hz @ 11.000 1/min

Features	Note	Values
Tacho frequency		300 Hz @ 9.000 1/min

Note:
 Each fan has its own tacho output signal
Tacho inlet side frequency = 366 Hz
Tacho outlet side frequency = 300 Hz

3.4 Electrical Features

Electronic function	Speed-Controlled	
Reversed polarity protection	Rectifying diode	
Max. residual current at U_N	$I_F < 1 \text{ mA}$	
Locked rotor protection	Auto restart	
Locked rotor current at U_N	I_{block} approx. 800 mA	
Clock signal at locked rotor	t_3 / t_4 typical: 0,5 s / 10 s	
Extended Downtime	t_5 : 30 s after 5 start-up tests	
Internal fuse	Littelfuse NANO2 > Very Fast-Acting > 451/453 Series 10A / 125V (Art.No.: 0451010.MRL)	
Voltage control *)	Fan turns on at $U_B > 36 \text{ V}$ or $< 62 \text{ V}$ Fan turns off at $U_B < 34 \text{ V}$ or $> 64 \text{ V}$	

*) This fan has an undervoltage and overvoltage control circuit integrated which turns the motor off if the voltage is out of range.

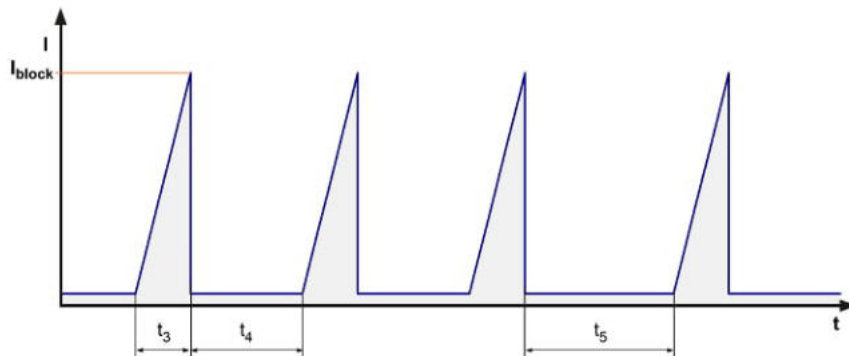

Inrush current limiter:

This fan is equipped with an inrush current limiter to reduce the charging current of the internal capacitors 220 μ F/75V. By this circuit the fan gets a start-up delay of 0,5 s after connecting the supply voltage. Only a short peak current can be measured at the inrush by charging the small internal filter capacitors with approximately 5 μ F.

3.5 Data According ErP Directive

Installation / Efficiency category	A / static
Speed control	integrated
Specific ratio	1,01060
Target overall efficiency 2015	29,0 %
Overall efficiency	55,8 %
Efficiency grade	40
Power input	185 W
Speed	11.000 1/min

All values measured in optimum energy efficiency point.

Productiondatecode is printed on the fan label.

3.6 Aerodynamics

Measurement conditions:

Measured with a double chamber intake rig acc. to DIN EN ISO 5801.

Normal air density = 1,2 kg/m³; Temperature 23°C +/- 3°C;

In the intake and outlet area should not be any solid obstruction within 0,5 m. Motor shaft horizontal.

The information is only valid under the specified test conditions and may be changed by the installation conditions. If there are deviations from the standard test conditions, the characteristic values must be checked under the installed conditions. Power consumption of the fan motor when operating at normal voltage is shown. Depending on the operating conditions of the application, the power input may be higher.

a.) Operation condition:

11.000 1/min at free air flow	PWM 100 %; f: 2 kHz		
-------------------------------	---------------------	--	--

Max. free-air flow ($\Delta p = 0 / \dot{V} = \text{max.}$)	540 m ³ /h	
Max. static pressure ($\Delta p = \text{max.} / \dot{V} = 0$)	1.520 Pa	

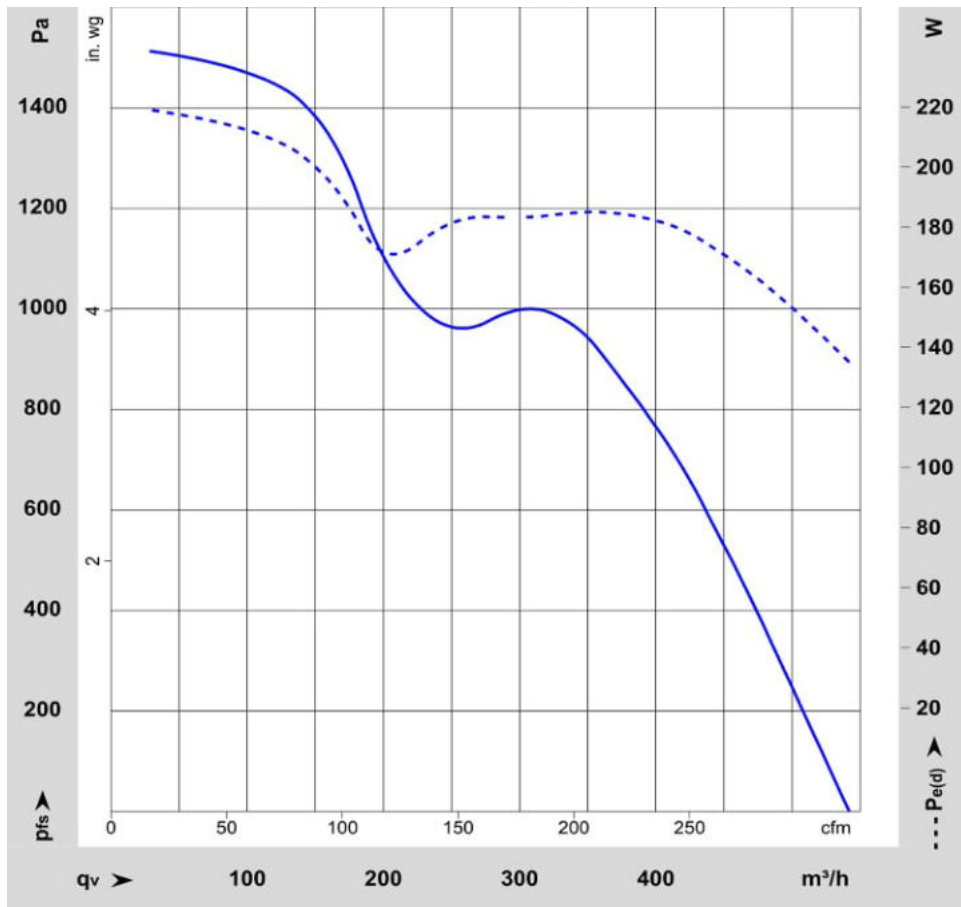

3.7 Sound Data

Measurement conditions: Sound pressure level: 1 meter distance between microphone and the air intake.
Sound power level: According to ISO 13347-3.
Measured in a semianechoic chamber with a background noise level of $L_p(A) < 5 \text{ dB(A)}$
For further measurement conditions see chapter aerodynamics.

a.) Operation condition:

11.000 1/min at free air flow	PWM 100 %; f: 2 kHz		
-------------------------------	---------------------	--	--

Optimal operating point	410 m ³ /h @ 730 Pa		
Sound power level at the optimal operating point	9,1 bel(A)		
Sound pressure level at free air flow, measured in rubber bands	84 dB(A)		

4 Environment

4.1 General

Min. permitted ambient temperature TU min.	-20 °C		
Max. permitted ambient temperature TU max.	70 °C		
Min. permitted storage temperature TL min.	-40 °C		
Max. permitted storage temperature TL max.	80 °C		

4.2 Climatic Requirements

IP-protection type (certified)	IP 20 **)		
Humidity requirements	humid heat, cyclic; according to DIN EN 60068-2-30, 6 cycle		
Salt fog requirements	None		

Permitted application area:

The product is for the use in sheltered rooms with limited controlled temperature. Occasionally condensed water is allowed. Direct exposure to water must be avoided. Saline ambient conditions must be avoided.

Pollution degree 2 (according DIN EN 60664-1)

It occurs only non-conductive pollution. Occasionally, temporary conductivity caused by condensation occurs.

**) The specification of the IP protection refers to the conditions mentioned in certification of the fan. The above mentioned short description of the protection scope is not final. For detailed information of the respective protection scope and definitions, see certification as well as DIN EN 60529 (protection by housings) and ISO 20653 (for vehicles) with the letter K.

Short description of the IP-protection type:

Solid particle Protection: Protected against solid particles with a diameter of 12.5 mm and larger.

Protection against deliberate contact: Protected against contact to hazardous parts with a finger.

Protection against water: No protection.

4.3 Mechanical Requirements

severity level	Vibration (sinusoidal)	
1 G	Vibration (sinusoidal) in use IEC 60068-2-6 Displacement / frequency range Acceleration / frequency range Sweep rate Sweep cycles Duration Axes of vibration	Vibration (sinusoidal) 0,075 mm / 10-58, 58-10 Hz 1 G / 58-500-58 Hz 1 Oct./min 10 2 hrs. 3

severity level	stationary use		
1	storage / transportation	Random vibration not in use IEC 60068-2-64 Frequency range / ASD G _{RMS} Axes of vibration Test duration	Random vibration 5 - 20 Hz : 1,0 m ² / s ³ 20 - 500 Hz : - 3 dB / Oct 0,91 G 3 3 x 5 h
	storage / transportation	Bump not in use IEC 60068-2-29 Shock spectrum Acceleration Duration Number of bumps (+X, -X, -Y, +Y, -Z, +Z) Total bumps	Bump half sine 18 G 6 ms 100 in each direction 600
	stationary use	Random vibration in use IEC 60068-2-64 Frequency range / ASD G _{RMS} Axes of vibration Test duration	Random vibration 5 - 20 Hz : 2,0 m ² / s ³ 20- 150 Hz : - 3 dB / Oct 0,83 G 3 3 x 5 h
	stationary use	Bump in use IEC 60068-2-29 Shock spectrum Acceleration Duration Number of bumps (+X, -X, -Y, +Y, -Z, +Z) Total bumps	Bump half sine 5 G 11 ms 100 in each direction 600

4.4 EMC

Kind	Conducted Emission; Voltage; 150 kHz-30 MHz
Accordinging	DIN EN 55032:2016-02
Check accuracy / Limit	Class B
Result	Below limit Class B

Kind	Radiated Emission; 30 MHz - 1000 MHz
Accordinging	DIN EN 55032:2016-02
Check accuracy / Limit	Class B
Result	Below limit Class B

Kind	Electrostatic Discharge Immunity Test
Accordinging	DIN EN 61000-4-2:2001-12
Check accuracy / Limit	Contact Discharge +/- 4 kV; Air Discharge +/- 8 kV
Result	A: The monitored function operates as designed during and after exposure to a disturbance.

Kind	Electromagnetic Field Immunity Test
Accordinging	DIN EN 61000-4-3:2006-12
Check accuracy / Limit	10 V/m; 80 - 1000 MHz; AM; m = 0,8; f = 1 kHz; 1%; t = 3 s
Result	A: The monitored function operates as designed during and after exposure to a disturbance.

Kind	Electrical Fast Transient / Burst Immunity Test
Accordinging	DIN EN 61000-4-4:2005-07
Check accuracy / Limit	+/- 2 kV on Power Lines; Coupling: POS, NEG, {PE}, ALL, 5 kHz and 100 kHz; 1 min
Result	A: The monitored function operates as designed during and after exposure to a disturbance.

5 Safety**5.1 Electrical Safety**

Dielectric strength DIN EN 62368 and DIN EN 60335 A.) Type test Measuring conditions: After 48h of storage at 95% R.H. and 25°C. No arcing or breakdown is allowed! All connections together to ground. B.) Routine test Measuring conditions: At indoor climate. No arcing or breakdown is allowed! All connections together to ground.	500 VAC / 1 Min. 850 VDC / 1 Sec.	
Isolation resistance Measuring conditions: After 48h of storage at 95% R.H. and 25°C measured with U=500 VDC for 1 min.	RI > 10 MOhm	
Clearance / creepage distance	1,0 mm / 1,5 mm	
Protection class	III	

5.2 Approval Tests

CE	EC Declaration of Conformity	Yes
EAC	Eurasian Conformity	Yes
UL	Underwriters Laboratories	Yes / UL507, Electric Fans E38324
VDE	Association for Electrical, Electronic and Information Technologies	Yes / Approval acc. to EN 62368 - Audio/video, information and communication technology equipment
CSA	Canadian Standards Association	Yes / CSA audited by UL according to C22.2 No. 113 Fans and Ventilators
CCC	China Compulsory Certification	Yes / GB 12350 Safety Requirements for small Power Motors

The approval tests are observed to:

U approval max.: @ TU approval max.: 60 °C

6 Reliability**6.1 General**

Life expectancy L10 acc. to IPC 9591 at TU = 40 °C	70.000 h	
----------------------------------------------------	----------	--

The information, data source and selection of this document as well as the transmission of its contents without express authorization is prohibited. Otherwise all the data shown in this document is the property of Ebmpapst. All rights reserved in the event of a patent, utility model or design. Trade or company name (D) (BIB)

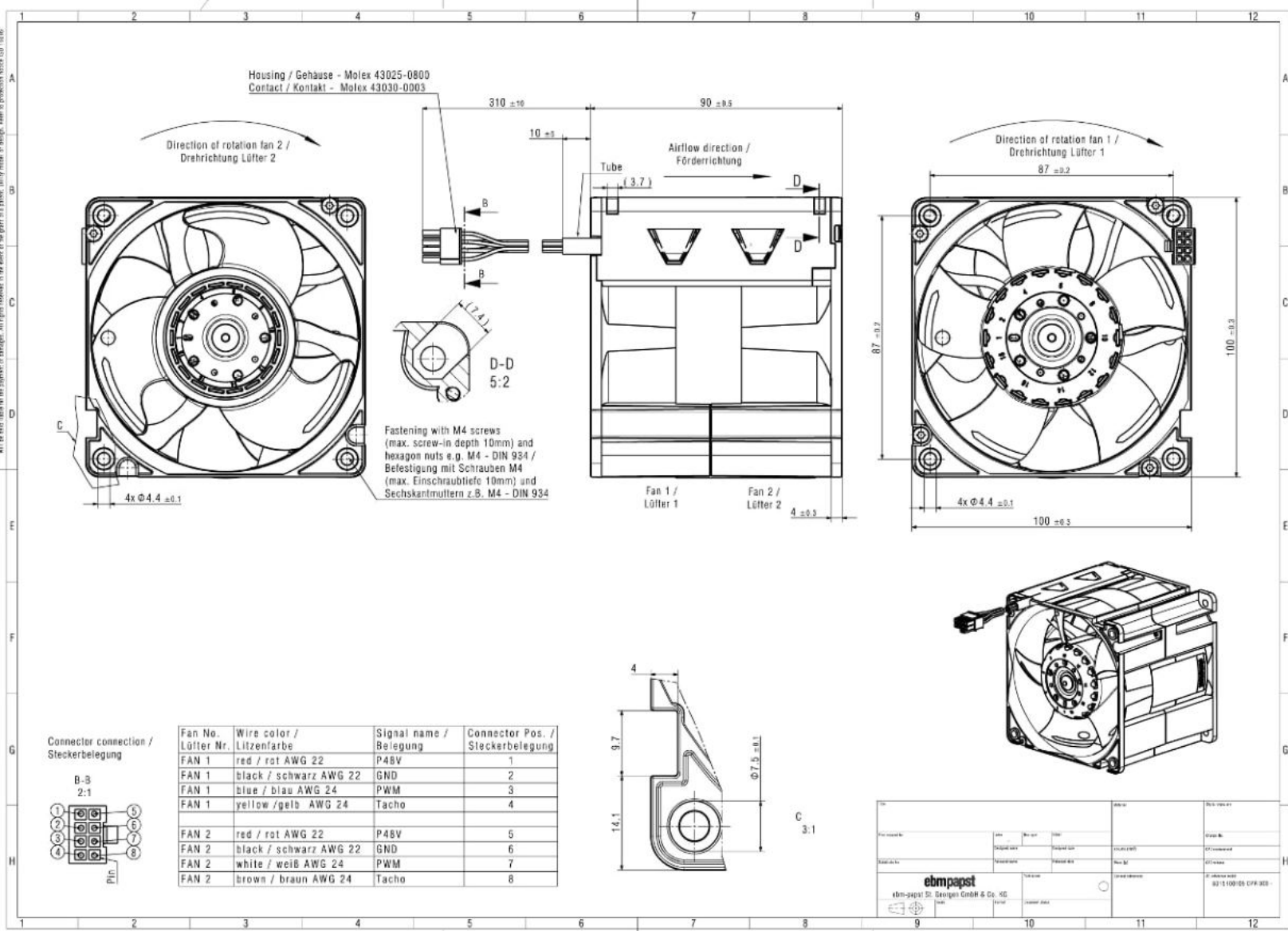

Housing / Gehäuse - Molex 43025-0800
Contact / Kontakt - Molex 43030-0003

Direction of rotation fan 2 /
Drehrichtung Lüfter 2

Airflow direction /
Förderrichtung

Direction of rotation fan 1 /
Drehrichtung Lüfter 1

Fastening with M4 screws
(max. screw-in depth 10mm) and
hexagon nuts e.g. M4 - DIN 934 /
Befestigung mit Schrauben M4
(max. Einschraubtiefe 10mm) und
Sechskantmüllern z.B. M4 - DIN 934

Fan 1 /
Lüfter 1 Fan 2 /
Lüfter 2

Connector connection /
Steckerbelegung

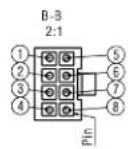

Fan No. / Lüfter Nr.	Wire color / Litzenfarbe	Signal name / Belegung	Connector Pos. / Steckerbelegung
FAN 1	red / rot AWG 22	P48V	1
FAN 1	black / schwarz AWG 22	GND	2
FAN 1	blue / blau AWG 24	PWM	3
FAN 1	yellow / gelb AWG 24	Tacho	4
FAN 2	red / rot AWG 22	P48V	5
FAN 2	black / schwarz AWG 22	GND	6
FAN 2	white / weiß AWG 24	PWM	7
FAN 2	brown / braun AWG 24	Tacho	8

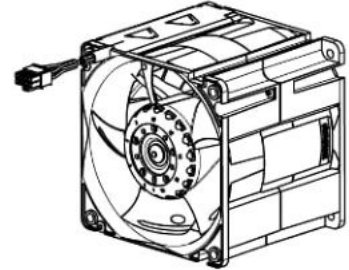
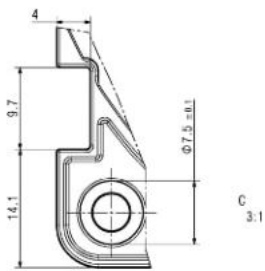

ebmpapst ebm-papst St. Georgen GmbH & Co. KG www.ebmpapst.com		87100-05 (D) 05	
Date: _____ Drawn: _____ Checked: _____	Date: _____ Drawn: _____ Checked: _____	Date: _____ Drawn: _____ Checked: _____	Date: _____ Drawn: _____ Checked: _____