

Product Data Sheet 7214 N/19

**ebmpapst**

The engineer's choice



7214 N/19

INDEX

<b>1</b>	<b>General .....</b>	<b>3</b>
<b>2</b>	<b>Mechanics .....</b>	<b>3</b>
2.1	General .....	3
2.2	Connections .....	3
<b>3</b>	<b>Operating Data .....</b>	<b>4</b>
3.1	Electrical Operating Data .....	4
3.2	Electrical Interface - Output .....	5
3.3	Electrical Features .....	6
3.4	Aerodynamics .....	7
3.5	Sound Data .....	8
<b>4</b>	<b>Environment.....</b>	<b>8</b>
4.1	General .....	8
4.2	Climatic Requirements.....	8
<b>5</b>	<b>Safety.....</b>	<b>9</b>
5.1	Electrical Safety .....	9
5.2	Approval Tests .....	9
<b>6</b>	<b>Reliability.....</b>	<b>9</b>
6.1	General .....	9

**1 General**

Fan type	Fan	
Rotating direction looking at rotor	Counterclockwise	
Airflow direction	Air outlet over struts	
Bearing system	Ball bearing	
Mounting position - shaft	Any	

**2 Mechanics**

**2.1 General**

Depth	55,0 mm	
Diameter	150,0 mm	
Mass	0,725 kg	
Housing material	Metal	
Impeller material	Plastic	
Max. torque when mounted across both mounting flanges	Wire outlet corner: 560 Ncm Remaining corners: 560 Ncm	
Screw size	ISO 4762 - M4 degreased, without an additional brace and without washer	

**2.2 Connections**

Electrical connection	Wires	
Lead wire length	L = 365 mm	
Tolerance	+ - 10,0 mm	
Tube length	S = 10 mm	
Tolerance	+ - 5,0 mm	
Wire size (AWG)	22	
Insulation diameter	1,70 mm	

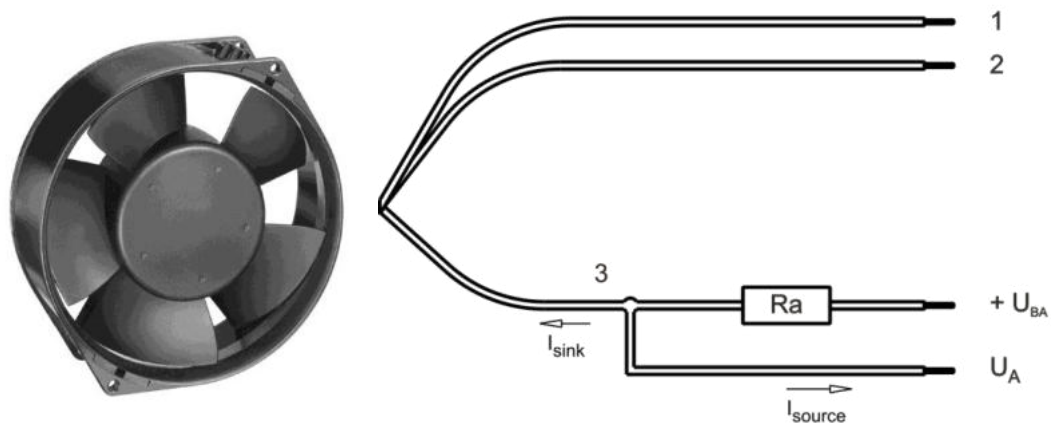

Wire	Color	Operation
1	red	+ UB
2	black	- GND
3	white	Alarm

The auxiliaries shown on the schematic diagram (which are required for the intended use) are not part of our delivery.

### 3 Operating Data

#### 3.1 Electrical Operating Data

Measurement conditions: Normal air density = 1,2 kg/m<sup>3</sup>; Temperature 23°C +/- 3°C; Motor axis horizontal; warm-up time before measuring 5 minutes (unless otherwise specified). In the intake and outlet area should not be any solid obstruction within 0,5 m.

$\Delta p = 0$ : corresp. to free air flow (see chapter aerodynamics)  
I: corresp. to arithm. mean current value

Note:

No inrush current at Unom means:

The internal electrolytic capacitor 120uF/50V has no resistor or inrush current limitation, essentially the power supply and the type and length of the connecting cable is limiting the Inrush current.

Features	Condition	Symbol	Values		
Voltage range		U	12,0 V		30,0 V
Nominal voltage		U <sub>N</sub>		24,0 V	
Power consumption	$\Delta p = 0$	P	2,45 W	12 W	22 W
Tolerance	0010		+/- 20 %	+/- 25,0 %	+/- 25,0 %
Current consumption	$\Delta p = 0$	I	205 mA	500 mA	615 mA
Tolerance	0010		+/- 20,0 %	+/- 25,0 %	+/- 25,0 %
Speed	$\Delta p = 0$	n	1.500 1/min	3.050 1/min	3.620 1/min
Tolerance	0010		+/- 12,5 %	+/- 10,0 %	+/- 10,0 %
Starting current consumption				2.300 mA	

3.2 Electrical Interface - Output

Alarm type	/19 (low = ok, open collector inverse)
------------	----------------------------------------

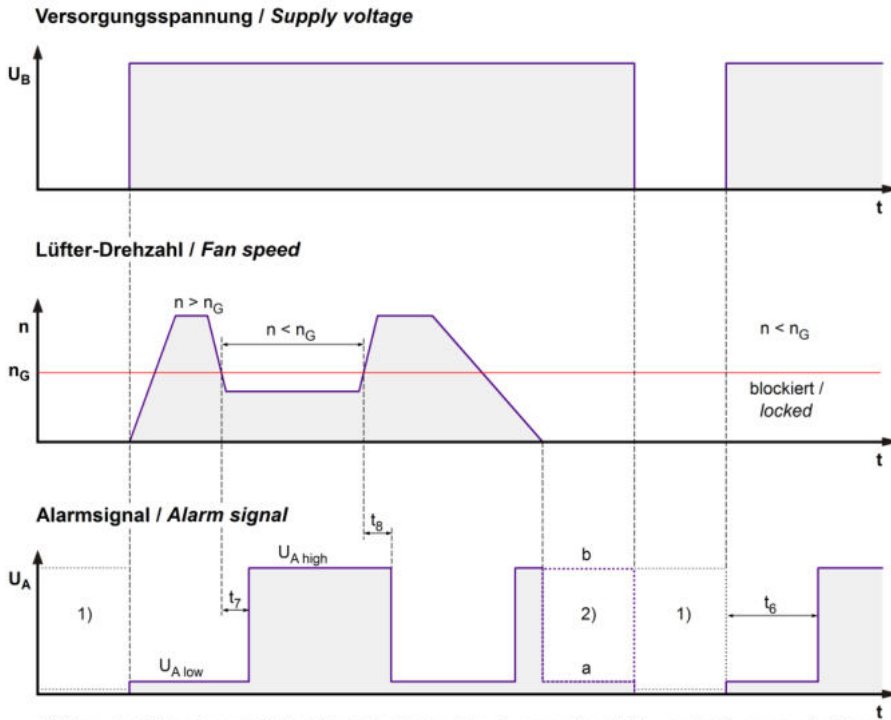

$$R_a = \frac{U_{BA} - U_{A\ low}}{I_{\ sink}}$$

Lüfter / Fan      Kunde / Customer

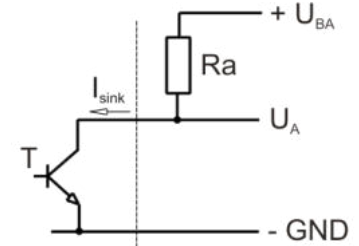

- 1) Wenn der Lüfter abgeschaltet ist, hängt der Zustand des Ausgangssignals  $U_A$  von der Kundenapplikation ab.  
 When the fan is powered off, the output signal  $U_A$  depends on the customer's application.  
 2) Für den gültigen Zustand (a oder b) siehe Alarmunterdrückung in der Tabelle.  
 For the valid condition (a or b) see alarm suppression in the table.

Features	Note	Values
Alarm operating voltage	$U_{BA}$	Max.: 60,0 V
Alarm signal Low	$U_{A\ low}$	$\leq 0,8\ V$
Alarm signal High	$U_{A\ high}$	60,0 V
Maximum sink current	$I_{\ sink}$	10 mA
External resistor	External resistor $R_a$ from $U_{BA}$ to $U_A$ required. All voltage measured to GND.	
Alarm start-up delay time	$t_6$	9,0 s
Tolerance		+ - 1,0 s
Alarm delay time	$t_7$	1,0 s
Tolerance		+ - 1,0 s
Alarm delay time	$t_9$	1,0 s
Tolerance		+ - 1,0 s
Alarm trip speed limit	$n_G$	1.800 1/min
Tolerance		+ - 100 1/min
Alarm at sense failure	No	
Alarm latch	No	
Alarm isolated from motor	No	

Alarm delay time  $t_2$  during the start up and after alarm reset.  
While operation ist  $t_2 = 0$  s.

### 3.3 Electrical Features

Electronic function	None	
Reversed polarity protection	Rectifying diode	
Max. residual current at $U_N$	$I_F < 10$ mA	
Locked rotor protection	Auto restart	
Locked rotor current at $U_N$	$I_{block}$ approx. 2.100 mA	
Clock signal at locked rotor	$t_3 / t_4$ typical: 1,4 s / 5,3 s	

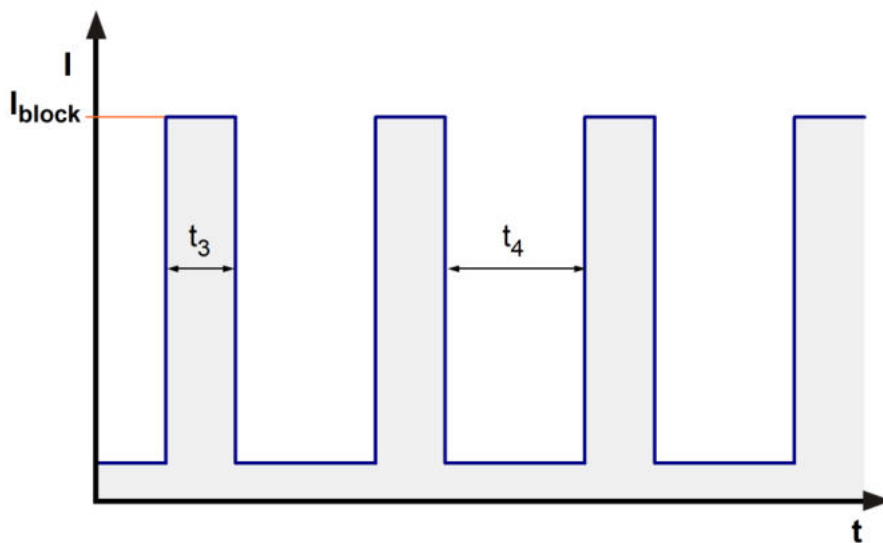

### 3.4 Aerodynamics

Measurement conditions:

Measured with a double chamber intake rig acc. to DIN EN ISO 5801.

Normal air density = 1,2 kg/m<sup>3</sup>; Temperature 23°C +/- 3°C;

In the intake and outlet area should not be any solid obstruction within 0,5 m. Motor shaft horizontal.

The information is only valid under the specified test conditions and may be changed by the installation conditions. If there are deviations from the standard test conditions, the characteristic values must be checked under the installed conditions.

a.) Operation condition:

3.050 1/min at free air flow

Max. free-air flow ( $\Delta p = 0 / \dot{V} = \text{max.}$ )	345,0 m <sup>3</sup> /h	
Max. static pressure ( $\Delta p = \text{max.} / \dot{V} = 0$ )	160 Pa	

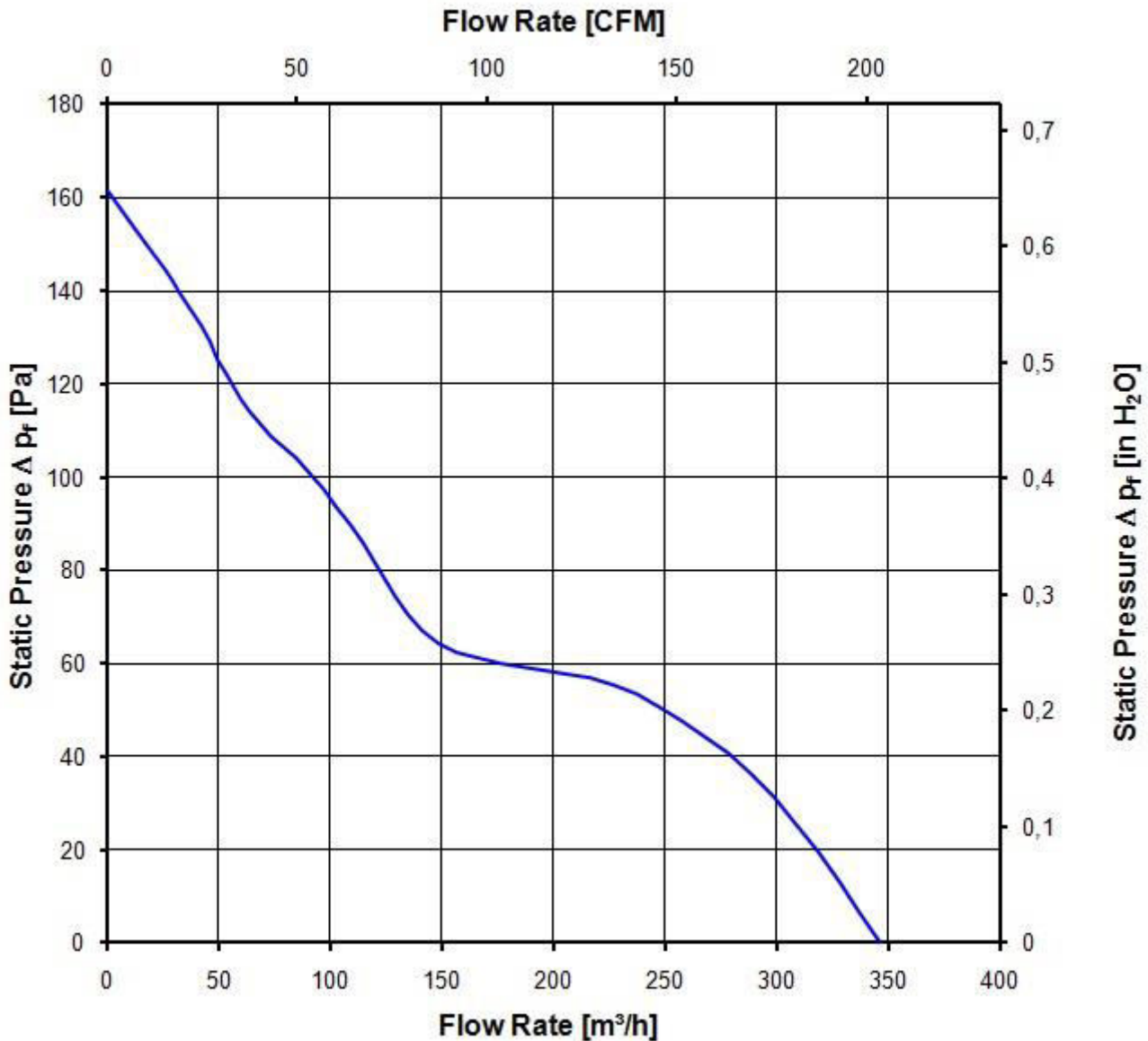

### 3.5 Sound Data

Measurement conditions: Sound pressure level: 1 meter distance between microphone and the air intake.  
 Sound power level: Acc. to DIN 45635 part 38 (ISO 10302)  
 Measured in a semianchoic chamber with a background noise level of  $L_p(A) < 5 \text{ dB(A)}$   
 For further measurement conditions see chapter aerodynamics.

a.) Operation condition:

3.050 1/min at free air flow		
Optimal operating point	220,0 m <sup>3</sup> /h @ 50 Pa	
Sound power level at the optimal operating point	6,2 bel(A)	
Sound pressure level at free air flow, measured in rubber bands	53,0 dB(A)	

## 4 Environment

### 4.1 General

Min. permitted ambient temperature TU min.	-25 °C	
Max. permitted ambient temperature TU max.	72 °C	
Min. permitted storage temperature TL min.	-40 °C	
Max. permitted storage temperature TL max.	80 °C	

### 4.2 Climatic Requirements

Humidity requirements	humid heat, constant; according to DIN EN 60068-2-78, 14 days	
Water exposure	None	
Dust requirements	None	
Salt fog requirements	None	

Permitted application area:

The product is intended for use in sheltered rooms with controlled temperature and controlled humidity. Directly exposure to water must be avoided.

Pollution degree 1 (according DIN EN 60664-1)

There is either no pollution or it occurs only dry, non-conductive pollution. The pollution has no negative impact.

Please require severity levels and specification parameters from the responsible development departments.



## 5 Safety

### 5.1 Electrical Safety

Dielectric strength DIN EN 60950 (VDE 0805) and DIN EN 60335 (VDE 0700) A.) Type test Measuring conditions: After 48h of storage at 95% R.H. and 25°C. No arcing or breakdown is allowed! All connections together to ground.	500 VAC / 1 Min.	
B.) Routine test Measuring conditions: At indoor climate. No arcing or breakdown is allowed! All connections together to ground.	500 VAC / 1 Sec.	
Isolation resistance Measuring conditions: After 48h of storage at 95% R.H. and 25°C measured with U=500 VDC for 1 min.	RI > 10 MOhm	
Clearance / creepage distance	1,0 mm / 1,2 mm	
Protection class	III	

### 5.2 Approval Tests

CE	EC Declaration of Conformity	Yes
EAC	Eurasian Conformity	Yes
UL	Underwriters Laboratories	Yes / UL audited by CSA according to UL507, Electric Fans
VDE	Association for Electrical, Electronic and Information Technologies	Yes / Approval acc. to EN 60950 (VDE 0805) - Information technology equipment
CSA	Canadian Standards Association	Yes / C22.2 No. 113 Fans and Ventilators
CCC	China Compulsory Certification	Not applicable

## 6 Reliability

### 6.1 General

Life expectancy L10 at TU = 40 °C	80.000 h	
Life expectancy L10 at TU max.	37.500 h	
Life expectancy L10 acc. to IPC 9591 at TU = 40 °C	135.000 h	

Parts of the document are copyright of ebmpapst. All rights reserved. No part of this document may be reproduced, stored in a retrieval system, or transmitted, in any form or by any means, electronic, mechanical, photocopying, recording, or by any information storage and retrieval system, without express written permission from ebmpapst. All rights reserved.

Schutzmarken nach DIN EN 60 073 (Vorsicht)  
 Marke für Produktanwendung: UL, ENEC

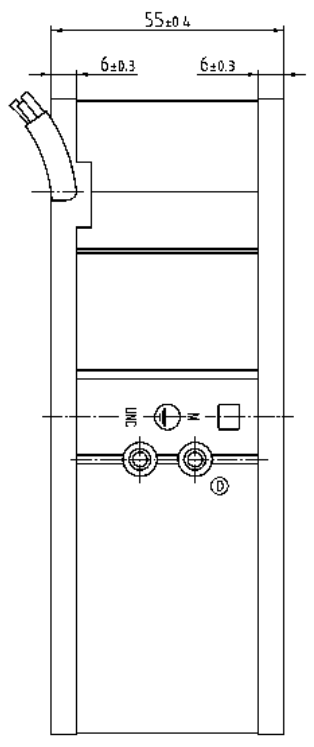

←  
 B. s. richtung /  
 blowing direction

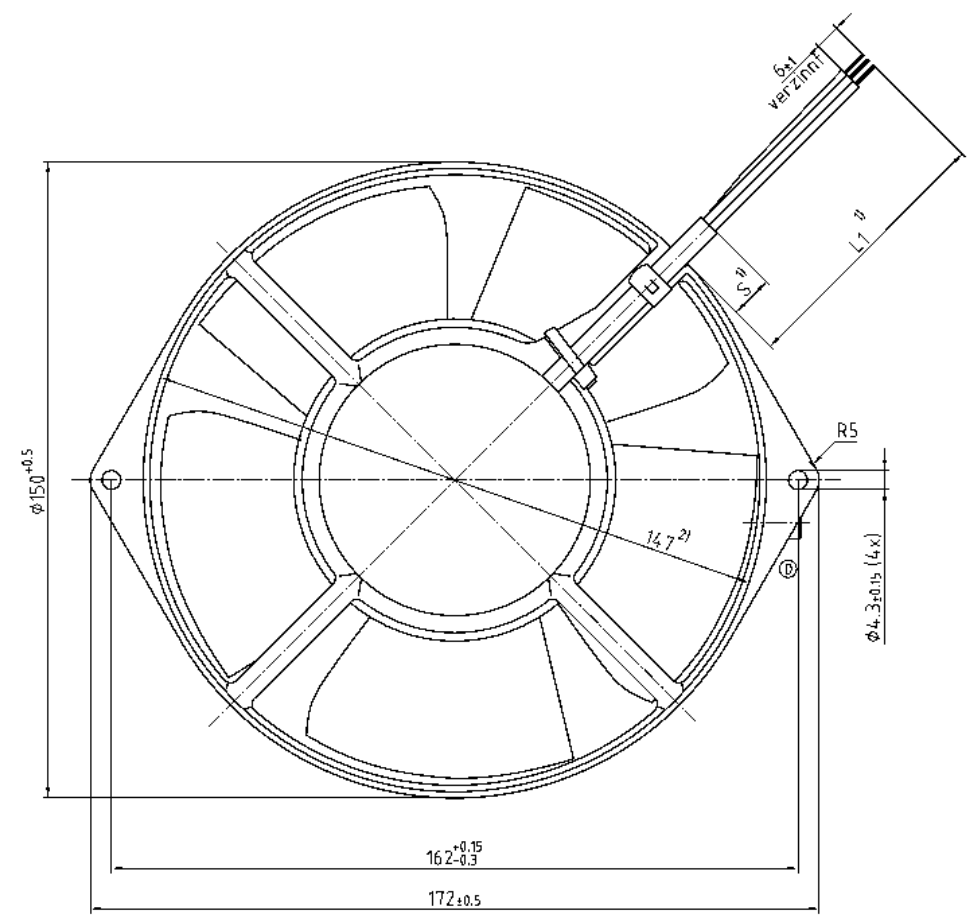

1) = Anzahl und Länge der Litzen sowie Länge des Schlauches s. Produkt Spezifikation Bl.3 /  
 length and number of wires and length of tube see product specification page 3  
 2) = Maße für Montagewand / dimensions for mounting wall

SAP-Status/Date	Text-Code-Nr.	Art-Nr./Part-Name	ehmpapst	Works/Of/Produkt	Volumen/Volumen (mm <sup>3</sup> )
		Behälter	CAD Umrechnung/ CAD Environment		Gewicht/Mass (kg)
		Bezeichnung	Name/Name	Art-Nr./Title	
Herstellung/Status		Bezeichnet/Checked			
Abgezeichnet/Con. des Zeich.		geprüft/Released			
			<b>ehmpapst</b>	Zug-Nr./Drawing-No.	Rev./Revisions
			ehmpapst St. Georgen GmbH & Co. KG	Produkttyp/Prod. Type	Produkt/Prod.