

Product Data Sheet 6318 N/2TDH3PU

ebmpapst

The engineer's choice



6318 N/2TDH3PU

INDEX

1	General	3
2	Mechanics	3
2.1	General.....	3
2.2	Connections.....	3
3	Operating Data	5
3.1	Electrical Interface - Input.....	5
3.2	Electrical Operating Data	6
3.3	Electrical Interface - Output.....	7
3.4	Electrical Features	7
3.5	Data According ErP Directive	8
3.6	Aerodynamics.....	9
3.7	Sound Data.....	11
4	Environment	11
4.1	General.....	11
4.2	Climatic Requirements	11
4.3	Mechanical Requirements.....	11
5	Safety	14
5.1	Electrical Safety	14
5.2	Approval Tests.....	14
6	Reliability	14
6.1	General.....	14

1 General

Fan type	Fan	
Rotating direction looking at rotor	Counterclockwise	
Airflow direction	Air outlet over struts	
Bearing system	Ball bearing	
Mounting position - shaft	Any	

2 Mechanics**2.1 General**

Depth	51,0 mm	
Diameter	172,0 mm	
Mass	0,875 kg	
Housing material	Metal	
Impeller material	Plastic	
Max. torque when mounted across both mounting flanges Screw size	Wire outlet corner: 440 Ncm Remaining corners: 440 Ncm ISO 4762 - M4 degreased, without an additional brace and without washer	

2.2 Connections

Electrical connection	Wires	
Lead wire length	L = 365 mm	
Tolerance	+ - 10,0 mm	
Tube length	S = 10 mm	
Tolerance	+ - 5,0 mm	

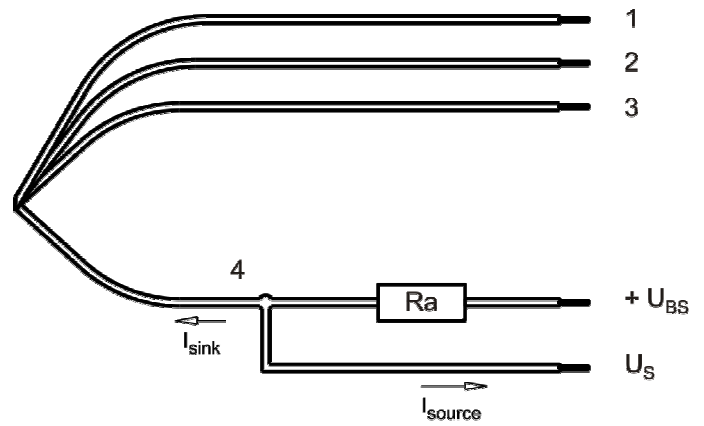

Wire	Color	Operation	Wire size	Insulation diameter
1	red	+ UB	AWG 20	2,05 mm
2	blue	- GND	AWG 20	2,05 mm
3	violet	PWM	AWG 22	1,7 mm
4	white	Tacho	AWG 22	1,7 mm

The auxiliaries shown on the schematic diagram (which are required for the intended use) are not part of our delivery.

Lead wire 1 - 2: AWG20 (Insulation diameter 2,05 mm)
 Lead wire 3 - 4: AWG22 (Insulation diameter 1,70 mm)

3 Operating Data

3.1 Electrical Interface - Input

Control input	PWM
---------------	-----

Features

Input type	Open collector	
PWM - Frequency		1 kHz - 20 kHz typical: 2 kHz

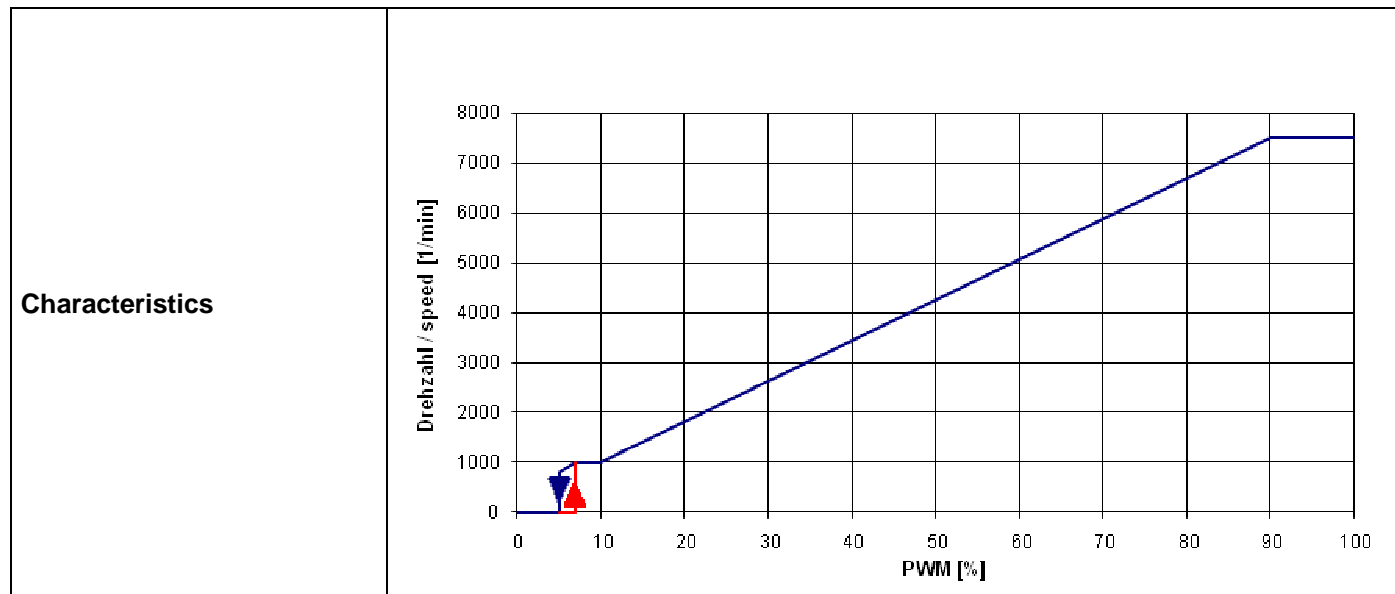

Lüfter / Fan

Kunde / Customer

Schematics

10% - 90% PWM: Linear increasing curve
 90% - 100% PWM: 7.500 1/min (corresp. to max fan speed)
 5% PWM: 800 1/min or 0 1/min (Fan turns off, coming from 100% PWM)

Transistor Requirements:

VCE max. \geq 12V
 Isink max $>$ 5mA
 VCEsat $<$ 0,15V

3.2 Electrical Operating Data

Measurement conditions: Normal air density = 1,2 kg/m³; Temperature 23°C +/- 3°C; Motor axis horizontal; warm-up time before measuring 5 minutes (unless otherwise specified). In the intake and outlet area should not be any solid obstruction within 0,5 m.

$\Delta p = 0$: corresp. to free air flow (see chapter aerodynamics)
 I: corresp. to arithm. mean current value

Name	Condition
PWM 0001	PWM: 95 %; f: 2 kHz

>90% PWM; f = 2 kHz or broken lead wire (open control input)

Features	Condition	Symbol	Values		
Voltage range		U	36 V		72,0 V
Nominal voltage		U _N		48,0 V	
Power consumption	$\Delta p = 0$	P	100 W	160 W	166 W
Tolerance	PWM 0010		+/- 10 %	+/- 7 %	+/- 10 %
Current consumption	$\Delta p = 0$	I	2.790 mA	3.330 mA	2.300 mA
Tolerance	PWM 0010		+/- 10 %	+/- 7 %	+/- 7 %
Speed	$\Delta p = 0$	n	6.320 1/min	7.500 1/min	7.500 1/min
Tolerance	PWM 0010		+/- 10 %	+/- 3 %	+/- 3 %

3.3 Electrical Interface - Output

Tacho type	/2 (open collector)
------------	---------------------

Signal-Ausgangsspannung / Signal output voltage

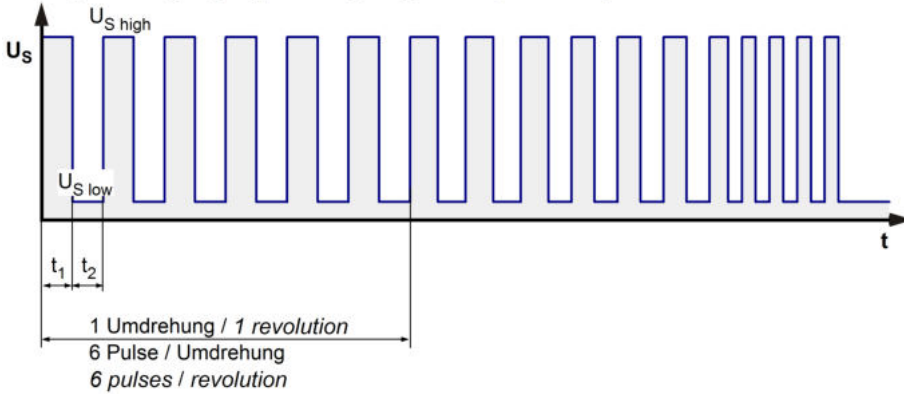

$$R_a = \frac{U_{BS} - U_{S\ low}}{I_{sink}}$$

Lüfter / Fan Kunde / Customer

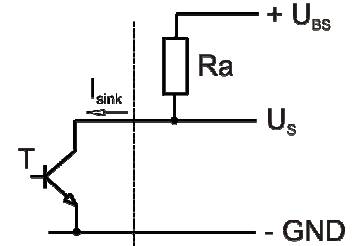

Lüfter-Drehzahl / Fan speed

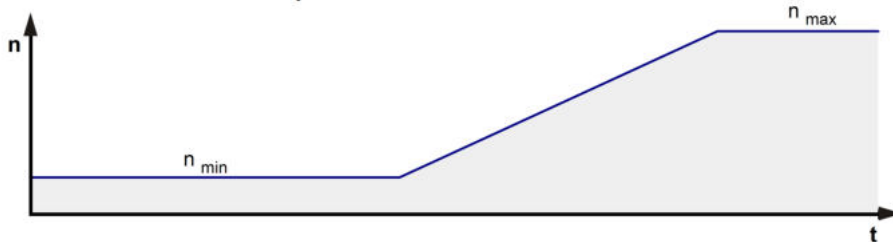

Features	Note	Values
Tacho operating voltage	U_{BS}	$\leq 60\text{ V}$
Tacho signal Low	$U_{S\ low}$	$\leq 0,4\text{ V}$
Tacho signal High	$U_{S\ high}$	$60,0\text{ V}$
Maximum sink current	I_{sink}	$\leq 20\text{ mA}$
External resistor	External resistor R_a from U_{BS} to U_S required. All voltages measured to GND.	
Tacho frequency	$(6 \times n) / 60$	750 Hz
Tacho isolated from motor	No	
Slew rate		$\Rightarrow 0,5\text{ V/us}$

n = revolutions per minute (1/min)

3.4 Electrical Features

Electronic function	Speed-Controlled	
Reversed polarity protection	P-CH FET	
Max. residual current at U_N	$I_F \leq 5\text{ mA}$	
Locked rotor protection	Auto restart	
Locked rotor current at U_N	I_{block} approx. 1.000 mA	
Clock signal at locked rotor	t_3 / t_4 typical: $5\text{ s} / 10,0\text{ s}$	

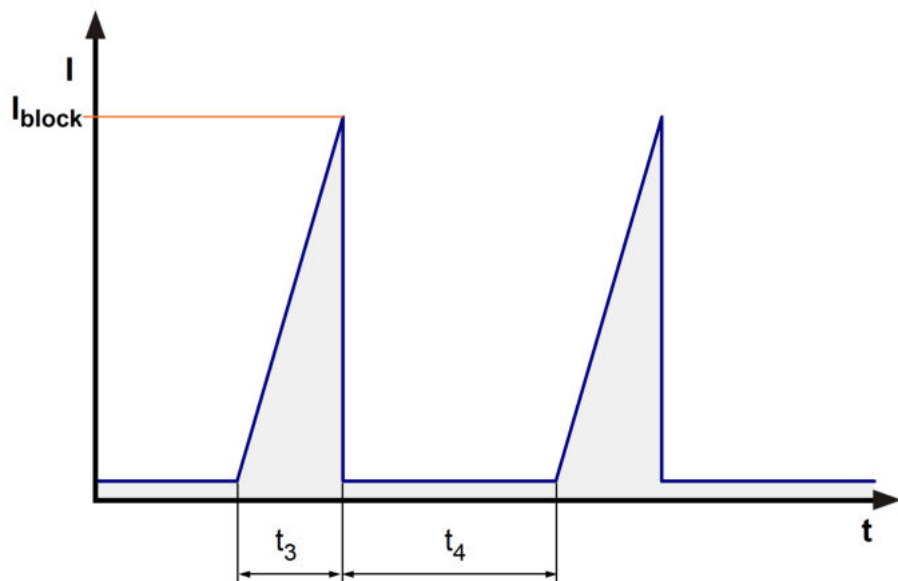

This fan has a startup delay of 2 seconds after applying supply voltage.

Internal Fuse: Littelfuse Nano2 Fuse Very Fast-Acting 451/453 Series 12A / 75V

3.5 Data According ErP Directive

Installation / Efficiency category	A / static
Speed control	integrated
Specific ratio	1,00457
Target overall efficiency 2015	29,2 %
Overall efficiency	48,9 %
Efficiency grade	40
Power input	194 W
Speed	7.400 1/min

All values measured in optimum energy efficiency point.

Productiondatecode is printed on the fan label.

3.6 Aerodynamics

Measurement conditions:

Measured with a double chamber intake rig acc. to DIN EN ISO 5801.

Normal air density = 1,2 kg/m³; Temperature 23°C +/- 3°C;

In the intake and outlet area should not be any solid obstruction within 0,5 m. Motor shaft horizontal.

The information is only valid under the specified test conditions and may be changed by the installation conditions. If there are deviations from the standard test conditions, the characteristic values must be checked under the installed conditions. Power consumption of the fan motor when operating at normal voltage is shown. Depending on the operating conditions of the application, the power input may be higher.

a.) Operation condition:

7.500 1/min at free air flow	PWM 95 %; f: 2 kHz		
Max. free-air flow ($\Delta p = 0 / \dot{V} = \text{max.}$)		1.040,0 m ³ /h	
Max. static pressure ($\Delta p = \text{max.} / \dot{V} = 0$)		1.100 Pa	

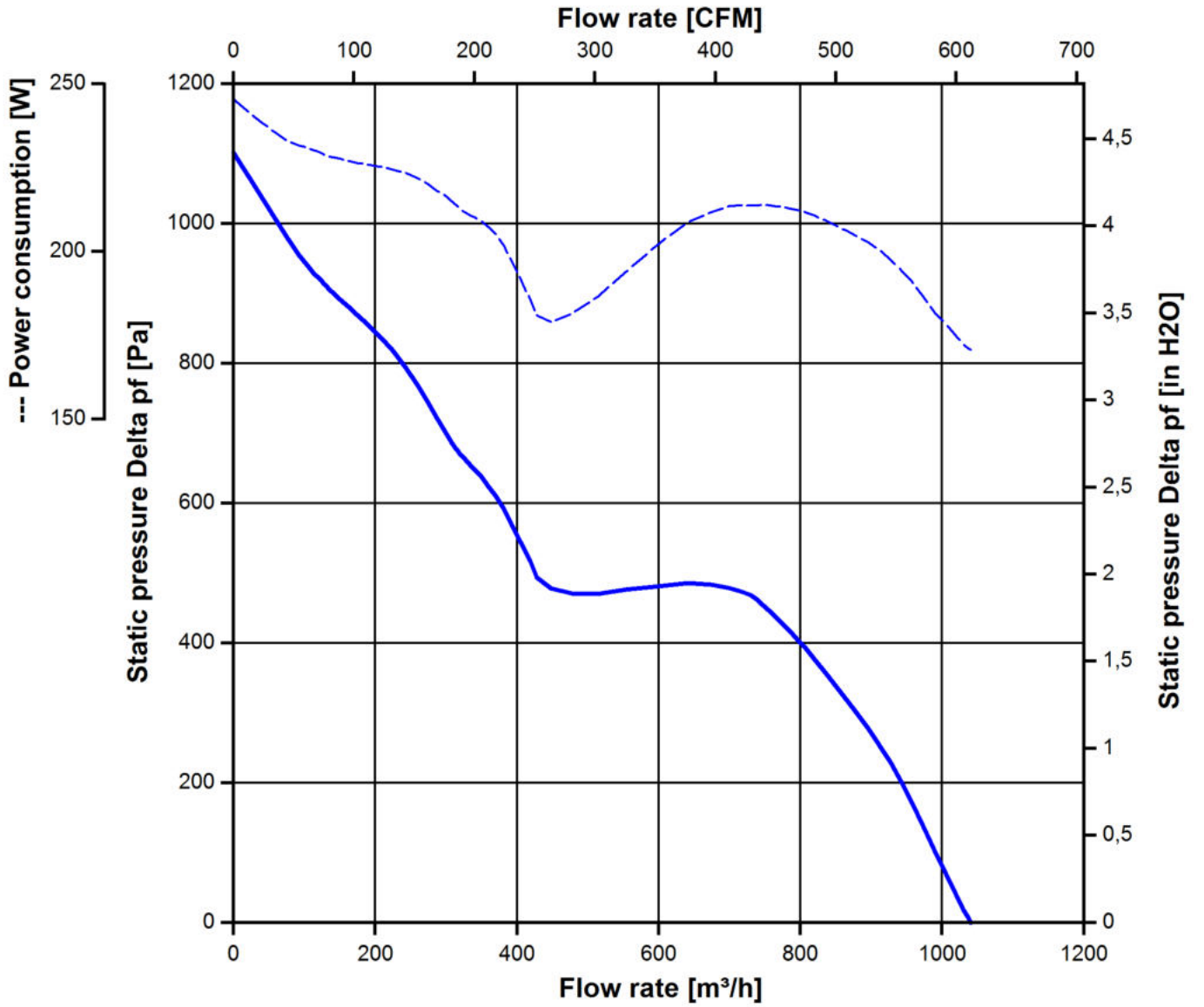

3.7 Sound Data

Measurement conditions: Sound pressure level: 1 meter distance between microphone and the air intake.

Measured in a semianchoic chamber with a background noise level of $L_p(A) < 5 \text{ dB(A)}$
 For further measurement conditions see chapter aerodynamics.

a.) Operation condition:

7.500 1/min at free air flow	PWM 95 %; f: 2 kHz		
------------------------------	--------------------	--	--

4 Environment

4.1 General

Min. permitted ambient temperature TU min.	-20 °C	
Max. permitted ambient temperature TU max.	65 °C	
Min. permitted storage temperature TL min.	-40 °C	
Max. permitted storage temperature TL max.	80 °C	

4.2 Climatic Requirements

Humidity requirements	humid temperature, cyclic; according to DIN EN 60068-2-38, 10 cycle and condensation water check; according to DIN EN ISO 6270-2, 14 days	
Water exposure	Splash water check IPX4; according to DIN EN 60529 VDE 0470, not certified	
Dust requirements	Dust check IP5X; according to DIN EN 60529 VDE 0470, not certified	
Salt fog requirements	None	

Permitted application area:

The product is for the use in partial sheltered rooms or open, roofed areas. Direct exposure to water is allowed provided that this does not prevent the normal operation. Saline ambient conditions must be avoided.

Pollution degree 3 (according DIN EN 60664-1)

It occurs conductive pollution or dry non-conductive pollution which becomes conductive due to condensation.

4.3 Mechanical Requirements

severity level	Vibration (sinusoidal)	
0,5 G	Vibration (sinusoidal) in use IEC 60068-2-6 Displacement / frequency range Acceleration / frequency range Sweep rate Sweep cycles Duration Axes of vibration	Vibration (sinusoidal) 0,035 mm / 10-60, 60-10 Hz 0,5 G / 60-500-60 Hz 1 Oct./min 10 2 hrs. 3

severity level	stationary use		
1	storage / transportation	Random vibration not in use IEC 60068-2-64 Frequency range / ASD G_{RMS} Axes of vibration Test duration	Random vibration 5 - 20 Hz : $1,0 \text{ m}^2 / \text{s}^3$ 20 - 500 Hz : - 3 dB / Oct 0,91 G 3 3 x 5 h
	storage / transportation	Bump not in use IEC 60068-2-29 Shock spectrum Acceleration Duration Number of bumps (+X, -X, -Y, +Y, -Z, +Z) Total bumps	Bump half sine 18 G 6 ms 100 in each direction 600
	stationary use	Random vibration in use IEC 60068-2-64 Frequency range / ASD G_{RMS} Axes of vibration Test duration	Random vibration 5 - 20 Hz : $2,0 \text{ m}^2 / \text{s}^3$ 20- 150 Hz : - 3 dB / Oct 0,83 G 3 3 x 5 h
	stationary use	Bump in use IEC 60068-2-29 Shock spectrum Acceleration Duration Number of bumps (+X, -X, -Y, +Y, -Z, +Z) Total bumps	Bump half sine 5 G 11 ms 100 in each direction 600

severity level	Railroad application		
1 IEC 61373 Category 1 Class B	Random vibration in use IEC 60068-2-64 Frequency range / ASD G_{RMS} Axes of vibration Test duration	Random vibration 5 - 20 Hz : $2,0 \text{ m}^2 / \text{s}^3$ 20- 150 Hz : - 3 dB / Oct 0,83 G 3 3 x 5 h	
	Shock in use IEC 60068-2-27 Shock spectrum Acceleration Duration Number of bumps (+X, -X, -Y, +Y, -Z, +Z) Total bumps	Shock half sine 7 G 18 ms 10 in each direction 60	

5 Safety

5.1 Electrical Safety

Dielectric strength DIN EN 60950 (VDE 0805) and DIN EN 60335 (VDE 0700) A.) Type test Measuring conditions: After 48h of storage at 95% R.H. and 25°C. No arcing or breakdown is allowed! All connections together to ground.	1000 VAC / 1 Min.	
B.) Routine test Measuring conditions: At indoor climate. No arcing or breakdown is allowed! All connections together to ground.	1700 VDC / 1 Sec.	
Isolation resistance Measuring conditions: After 48h of storage at 95% R.H. and 25°C measured with U=500 VDC for 1 min.	RI > 10 MOhm	
Clearance / creepage distance	1,0 mm / 1,5 mm	
Protection class	I	

5.2 Approval Tests

CE	EC Declaration of Conformity	Yes
EAC	Eurasian Conformity	Yes
UL	Underwriters Laboratories	Yes / UL507, Electric Fans
VDE	Association for Electrical, Electronic and Information Technologies	Yes / Approval acc. to EN 60950 (VDE 0805) - Information technology equipment
CSA	Canadian Standards Association	Yes / C22.2 No. 113 Fans and Ventilators
CCC	China Compulsory Certification	Yes / GB 12350 Safety Requirements for small Power Motors

6 Reliability

6.1 General

Life expectancy L10 at TU = 40 °C	60.000 h	
Life expectancy L10 at TU max.	30.000 h	
Life expectancy L10 acc. to IPC 9591 at TU = 40 °C	102. 500 h	

Explosions drawing: The drawings and parts list are the base for construction of the device. The drawings and parts list are the base for construction of the device. All dimensions are in millimeters.

Exploded view: The drawings and parts list are the base for construction of the device. The drawings and parts list are the base for construction of the device. All dimensions are in millimeters.

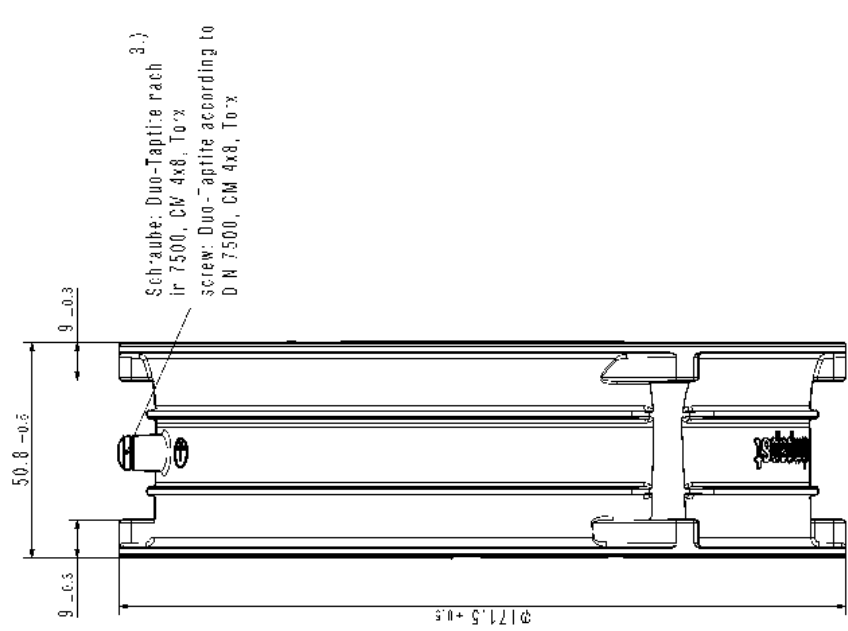
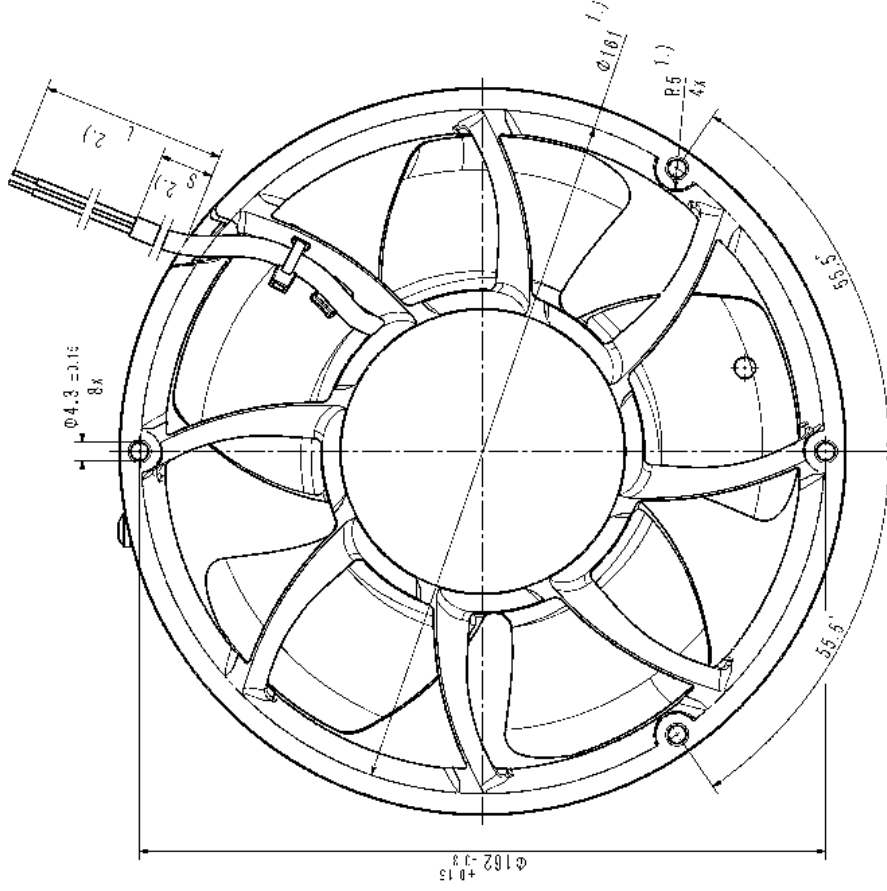

- 1.) Maße aus Montageausschnitt
- 2.) Anzahl und Länge der Litzen/Schlauch siehe Produktspezifikation
- 3.) Erdungsschraube nur wenn in der Luftergehäusestueckliste enthalten

- Axialspiel der Kugel aufget mit Feder spielfrei gelagert

- 1.) measures of mounting cut out
 - 2.) length an number of wires/tube see product specification
 - 3.) grounding screw only if contain in the fan housing part list
- ball bearing without clearance by a pre-load spring

0101 0101 0101	0101 0101 0101	0101 0101 0101	0101 0101 0101	0101 0101 0101	0101 0101 0101	0101 0101 0101
	0101 0101 0101	0101 0101 0101	0101 0101 0101	0101 0101 0101	0101 0101 0101	0101 0101 0101
0101 0101 0101	0101 0101 0101	0101 0101 0101	0101 0101 0101	0101 0101 0101	0101 0101 0101	0101 0101 0101