

Product Data Sheet 4158N/2H8P

ebmpapst

The engineer's choice



4158N/2H8P

INDEX

1	General	3
2	Mechanics	3
2.1	General	3
2.2	Connections	3
3	Operating Data	5
3.1	Electrical Interface - Input	5
3.2	Electrical Operating Data	6
3.3	Electrical Interface - Output	7
3.4	Electrical Features	7
3.5	Data According ErP Directive	9
3.6	Aerodynamics	10
3.7	Sound Data	11
4	Environment	11
4.1	General	11
4.2	Climatic Requirements	11
5	Safety	12
5.1	Electrical Safety	12
5.2	Approval Tests	12
6	Reliability	12
6.1	General	12

1 General

Fan type	Fan	
Rotating direction looking at rotor	Clockwise	
Airflow direction	Air intake over struts	
Bearing system	Ball bearing	
Mounting position - shaft	Any	

2 Mechanics**2.1 General**

Width	119,0 mm	
Height	119,0 mm	
Depth	38,0 mm	
Mass	0,425 kg	
Housing material	Metal	
Impeller material	Plastic	
Max. torque when mounted across both mounting flanges Screw size	Wire outlet corner: 420 Ncm Remaining corners: 600 Ncm ISO 4762 - M4 degreased, without an additional brace and without washer	

2.2 Connections

Electrical connection	Wires	
Lead wire length	L = 310 mm	
Tolerance	+ - 10,0 mm	

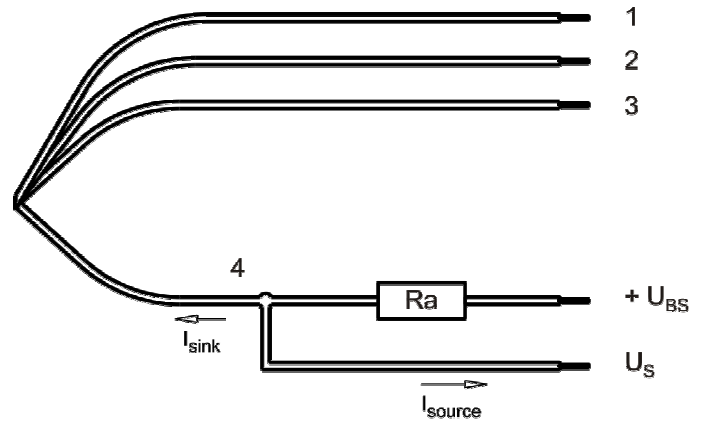

Wire	Color	Operation	Wire size	Insulation diameter
1	red	+ UB	AWG 20	2,05 mm
2	blue	- GND	AWG 20	2,05 mm
3	violet	PWM	AWG 22	1,7 mm
4	white	Tacho	AWG 22	1,7 mm

The auxiliaries shown on the schematic diagram (which are required for the intended use) are not part of our delivery.

3 Operating Data

3.1 Electrical Interface - Input

Control input	PWM
---------------	-----

Features

Input type	Open collector	
PWM - Frequency		1 kHz - 20 kHz typical: 2 kHz

Characteristics

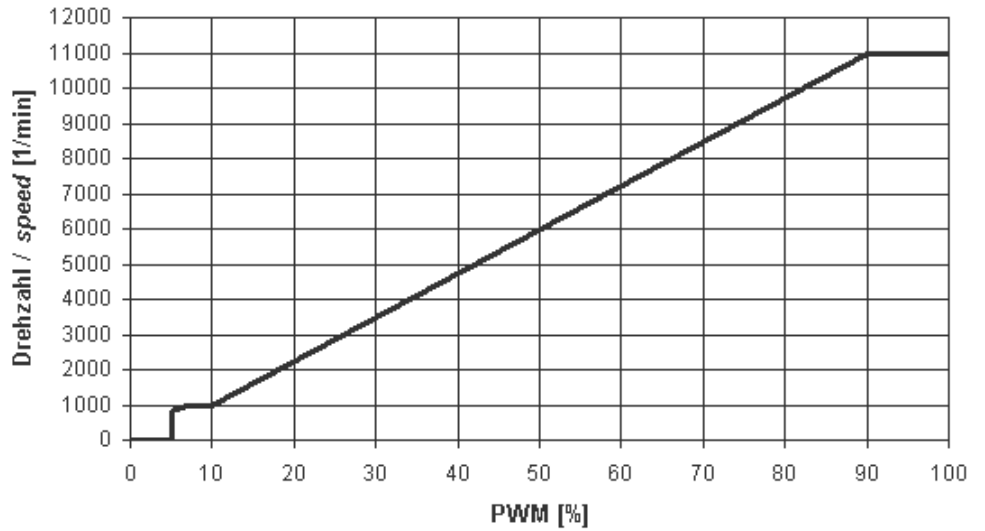

Lüfter / Fan

Kunde / Customer

Schematics

$V_{ce\ max.} \geq 12V$; $I_{sink\ max.} \geq 5mA$; $V_{ce\ sat.} \leq 0,15V$

3.2 Electrical Operating Data

Measurement conditions: Normal air density = 1,2 kg/m³; Temperature 23°C +/- 3°C; Motor axis horizontal; warm-up time before measuring 5 minutes (unless otherwise specified). In the intake and outlet area should not be any solid obstruction within 0,5 m.

$\Delta p = 0$: corresp. to free air flow (see chapter aerodynamics)
I: corresp. to arithm. mean current value

Name	Condition
PWM 0001	PWM: 95 %; f: 2 kHz

Note:

The internal electrolytic capacitor 47uF/100V has no resistor or inrush current limitation, essentially the power supply and the type and length of the connecting cable is limiting the Inrush current.

Features	Condition	Symbol	Values		
Voltage range		U	36 V		72 V
Nominal voltage		U_N		48 V	
Power consumption	$\Delta p = 0$	P	72 W	125 W	130,0 W
Tolerance	PWM 0010		+/- 10 %	+/- 10 %	+/- 10 %
Current consumption	$\Delta p = 0$	I	2.000 mA	2.600 mA	1.800 mA
Tolerance	PWM 0010		+/- 10 %	+/- 10 %	+/- 10 %
Speed	$\Delta p = 0$	n	9.150 1/min	11.000 1/min	11.000 1/min
Tolerance	PWM 0010		+/- 7,5 %	+/- 5 %	+/- 5 %

3.3 Electrical Interface - Output

Tacho type	/2 (open collector)
------------	---------------------

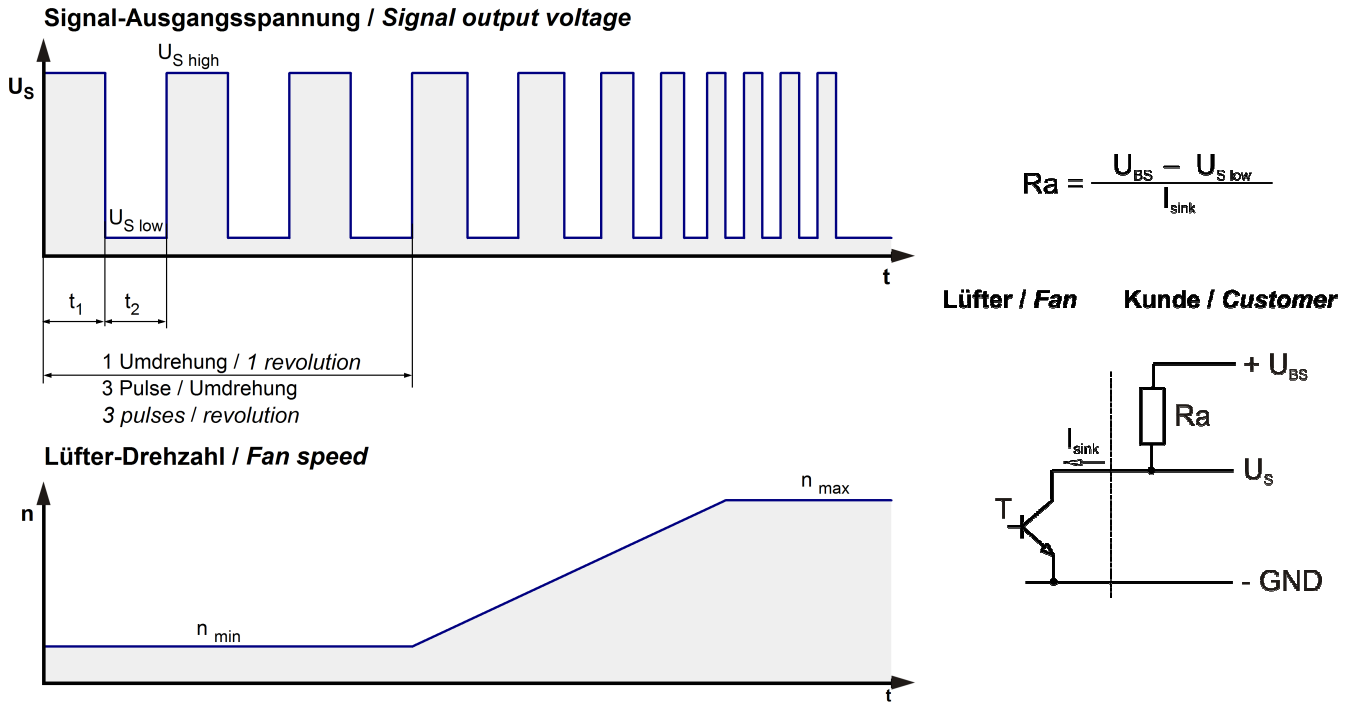

Features	Note	Values
Tacho operating voltage	U_{BS}	$\leq 60\text{ V}$
Tacho signal Low	$U_{S\ low}$	$\leq 0,4\text{ V}$
Tacho signal High	$U_{S\ high}$	$\leq 60\text{ V}$
Maximum sink current	I_{sink}	$\leq 20\text{ mA}$
External resistor	External resistor Ra from UBS to US required. All voltages measured to GND.	
Tacho frequency	$(3 \times n) / 60$	550 Hz @ 11.000 1/min
Tacho isolated from motor	No	
Slew rate		$\Rightarrow 0,5\text{ V/us}$

n = revolutions per minute (1/min)

Note to the tacho frequency: 3 pulses per revolution

During start-up or locked rotor condition the tacho is off (high). It turns on after a successful startup.

3.4 Electrical Features

Electronic function	Speed-Controlled	
Reversed polarity protection	N-CH FET	
Max. residual current at U_N	$I_F \leq 1\text{ mA}$	
Locked rotor protection	Auto restart	

Locked rotor current at U_N	I_{block} approx. 2.500 mA	
Clock signal at locked rotor Extended Downtime	t_3 / t_4 typical: 4 s / 10 s t_5 : 30 s after 5 start-up tests	
Internal fuse	Littelfuse NANO2 > Very Fast-Acting > 451/453 Series 6,3A / 125V (Art.No.: 045106.3MRL)	
Voltage control *)	Fan turns on at $U_B > 28$ V or < 75 V Fan turns off at $U_B < 26$ V or > 77 V	

*) This fan has an undervoltage and overvoltage control circuit integrated which turns the motor off if the voltage is out of range.

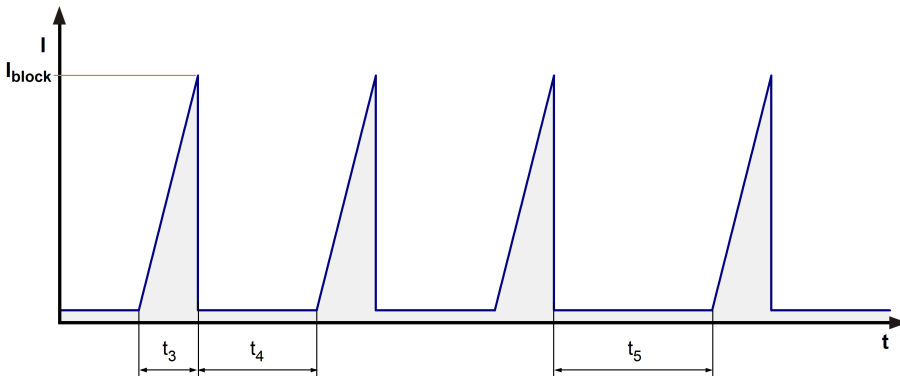

After 5 failed start-ups there is an extended timeout t_5 of 30 s.

When several fans are operated together (in a fan tray) and one fan starts after the other and the starting current is eventually limited, it can happen that the not yet operated fan is driven in reverse by the counter pressure. This can lead to a failure of the first start-up. The fan detects this and makes another start with an increased current.

The locked rotor current is denoted as peak-current at nominal voltage.

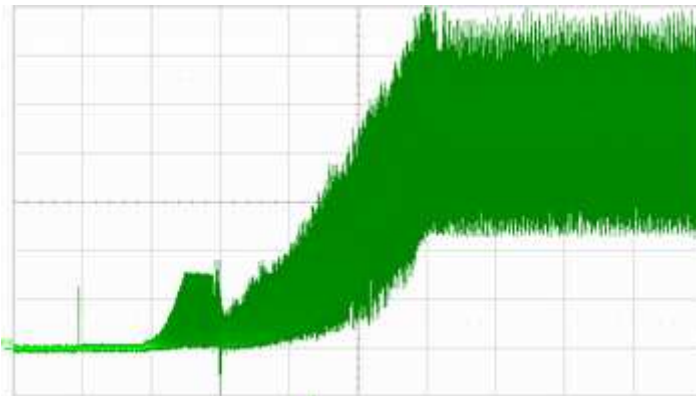

Start-up current @ 48 V ($I = 0,5A/div$; $t = 2s/div$)

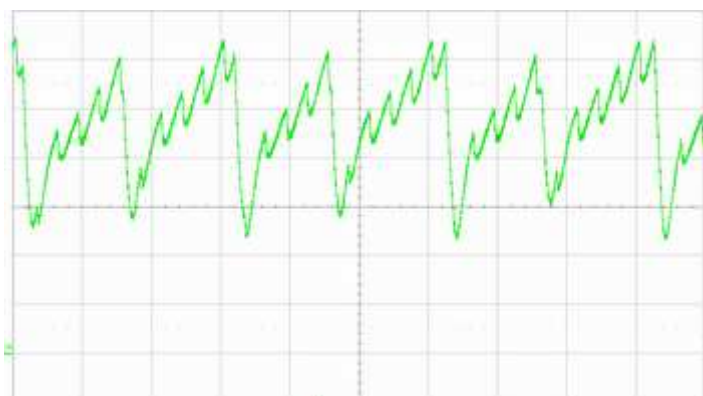

Typical running current @ 48 V (I = 0,5A/div ; t = 200us/div)

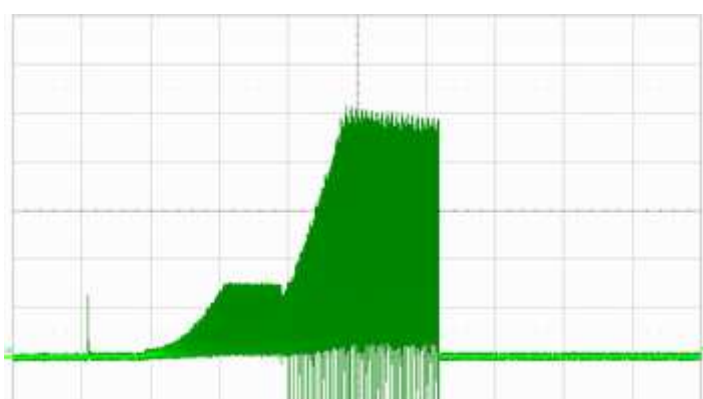

Locked rotor current @ 48 V (I = 0,5A/div ; t = 1s/div)

3.5 Data According ErP Directive

Installation / Efficiency category	A / static
Speed control	integrated
Specific ratio	1,00625
Target overall efficiency 2015	28,8 %
Overall efficiency	38,8 %
Efficiency grade	40
Power input	167 W
Speed	11.000 1/min

All values measured in optimum energy efficiency point.

Productiondatecode is printed on the fan label.

3.6 Aerodynamics

Measurement conditions:

Measured with a double chamber intake rig acc. to DIN EN ISO 5801.

Normal air density = 1,2 kg/m³; Temperature 23°C +/- 3°C;

In the intake and outlet area should not be any solid obstruction within 0,5 m. Motor shaft horizontal.

The information is only valid under the specified test conditions and may be changed by the installation conditions. If there are deviations from the standard test conditions, the characteristic values must be checked under the installed conditions.

a.) Operation condition:

11.000 1/min at free air flow	PWM 95 %; f: 2 kHz		
-------------------------------	--------------------	--	--

Max. free-air flow ($\Delta p = 0 / \dot{V} = \text{max.}$)	540 m ³ /h	
Max. static pressure ($\Delta p = \text{max.} / \dot{V} = 0$)	1.260 Pa	

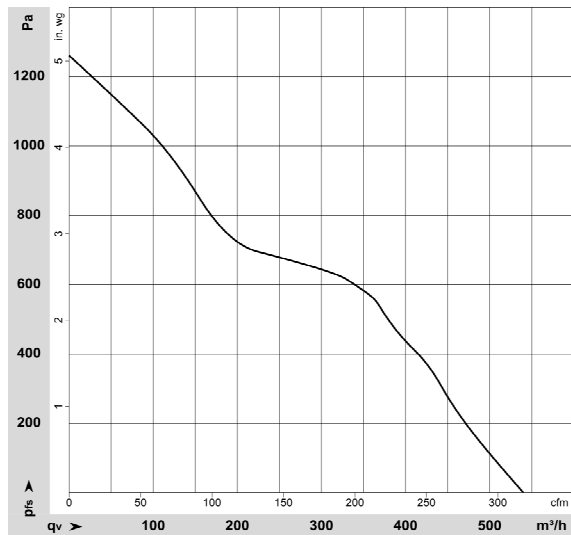

3.7 Sound Data

Measurement conditions: Sound pressure level: 1 meter distance between microphone and the air intake.
 Sound power level: According to ISO 13347-3.
 Measured in a semianchoic chamber with a background noise level of $L_p(A) < 5 \text{ dB(A)}$
 For further measurement conditions see chapter aerodynamics.

a.) Operation condition:

11.000 1/min at free air flow	PWM 95 %; f: 2 kHz		
-------------------------------	--------------------	--	--

Optimal operating point	320 m ³ /h @ 630 Pa	
Sound power level at the optimal operating point	8,9 bel(A)	
Sound pressure level at free air flow, measured in rubber bands	80 dB(A)	

4 Environment

4.1 General

Min. permitted ambient temperature TU min.	-20 °C	
Max. permitted ambient temperature TU max.	75 °C	
Min. permitted storage temperature TL min.	-40 °C	
Max. permitted storage temperature TL max.	80 °C	

4.2 Climatic Requirements

Humidity requirements	humid heat, constant; according to DIN EN 60068-2-78, 14 days	
Water exposure	None	
Dust requirements	None	
Salt fog requirements	None	

Permitted application area:

The product is intended for use in sheltered rooms with controlled temperature and controlled humidity. Directly exposure to water must be avoided.

Pollution degree 1 (according DIN EN 60664-1)

There is either no pollution or it occurs only dry, non-conductive pollution. The pollution has no negative impact.

Please require severity levels and specification parameters from the responsible development departments.

5 Safety

5.1 Electrical Safety

Dielectric strength DIN EN 60950 (VDE 0805) and DIN EN 60335 (VDE 0700) A.) Type test Measuring conditions: After 48h of storage at 95% R.H. and 25°C. No arcing or breakdown is allowed! All connections together to ground.	1000 VAC / 1 Min.	
B.) Routine test Measuring conditions: At indoor climate. No arcing or breakdown is allowed! All connections together to ground.	1700 VDC / 1 Sec.	
Isolation resistance Measuring conditions: After 48h of storage at 95% R.H. and 25°C measured with U=500 VDC for 1 min.	RI > 10 MOhm	
Clearance / creepage distance	1,0 mm / 1,5 mm	
Protection class	I	

5.2 Approval Tests

CE	EC Declaration of Conformity	No
EAC	Eurasian Conformity	Yes
UL	Underwriters Laboratories	Yes / UL507, Electric Fans
VDE	Association for Electrical, Electronic and Information Technologies	Yes / Approval acc. to EN 60950 (VDE 0805) - Information technology equipment
CSA	Canadian Standards Association	Yes / C22.2 No. 113 Fans and Ventilators
CCC	China Compulsory Certification	Yes / GB 12350 Safety Requirements for small Power Motors

6 Reliability

6.1 General

Attention!

In order to achieve the specified life time figure, it is necessary to connect an external capacitor close to the fan.

Complexity, connection, components and configuration must be checked at the project.

As a basis a capacitor of 220...1000 uF to the supply voltage between plus and minus can be used.

Life expectancy L10 at TU = 40 °C	55.000 h	
Life expectancy L10 at TU max.	22.500 h	
Life expectancy L10 acc. to IPC 9591 at TU = 40 °C	92.5 00 h	

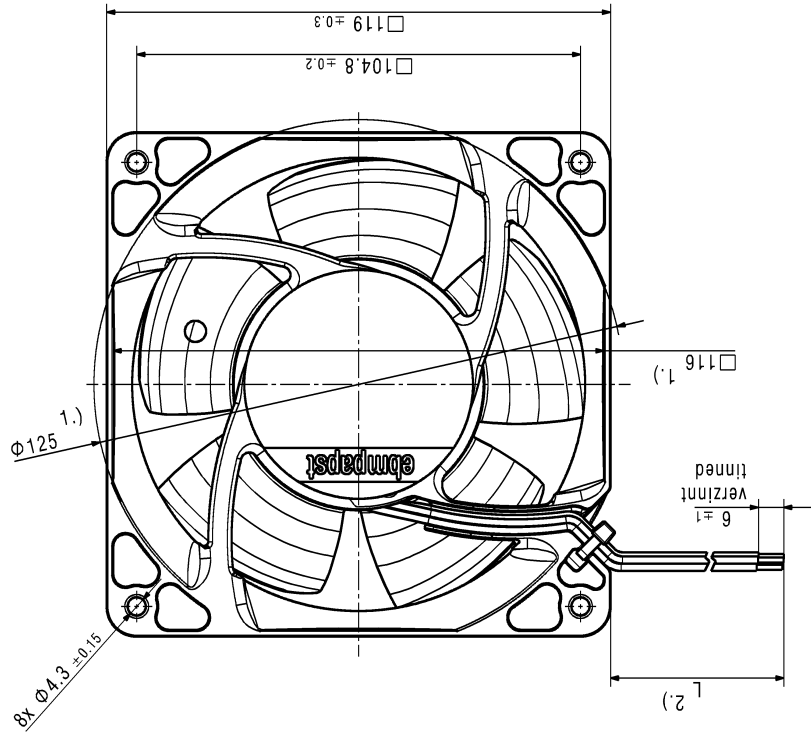

3.) Schraube Duo-Taprite nach:
Screw Duo-Taprite according to:
DIN 7500, CM 4x8, Torx

- 1.) Maße für Montageausschnitt.
 - 2.) Anzahl und Länge der Litzen siehe Produktspezifikation.
 - 3.) Nur wenn in Stückliste enthalten.
-- Axialspiel der Kugellager mit Feder spielfrei verspannt.
- 1.) Measures for mounting cut-out.
 - 2.) Length and number of wires see product specification.
 - 3.) Only if contained in BOM.
-- Ball bearing without axial clearance by a pre-load spring.

Document Status / Document-Status	CDT4-Verzinkt / CDT4-Verzinkt	CDT4-Modell / CDT4-Modell	Miniverst / Material:	Volumen / Volume (m ³):
Abw. Nr. / Change-No.	894614683 SP100	SP-Referenzmodell / SP-Referenzmodell	Titel / Title:	Gewicht / Weight (kg):
Tabularung / Tolerances:	Da tum	Name		Mess (l):
Abgemessen / Gen. Tolerances:				
			Doc. Nr. / Drawing No.	ERS / Zeich. / Revision:
			Docu. Nr. / Drawing No.	Form. / Zeich. / Mess (m):
			Docu. Nr. / Drawing No.	Form. / Zeich. / Mess (m):

Reproduction of this document, and giving it others and the use or communication of the contents thereof, are forbidden without express written consent. Reproduction and use are prohibited. All rights are reserved. In the event of the grant of a patent or the registration of a utility model or design.

Senden Sie Ihre Bestellung an: order@ebmpast.com oder an: www.ebmpast.com